

**ASME B31.12-2023**  
(Revision of ASME B31.12-2019)

# Hydrogen Piping and Pipelines

---

**ASME Code for Pressure Piping, B31**

**AN AMERICAN NATIONAL STANDARD**



**ASME B31.12-2023**  
(Revision of ASME B31.12-2019)

# Hydrogen Piping and Pipelines

---

**ASME Code for Pressure Piping, B31**

**AN AMERICAN NATIONAL STANDARD**



**The American Society of  
Mechanical Engineers**

Two Park Avenue • New York, NY • 10016 USA

Date of Issuance: December 29, 2023

The next edition of this Code is scheduled for publication in 2026. This Code will become effective 6 months after the Date of Issuance.

This code or standard was developed under procedures accredited as meeting the criteria for American National Standards. The standards committee that approved the code or standard was balanced to ensure that individuals from competent and concerned interests had an opportunity to participate. The proposed code or standard was made available for public review and comment, which provided an opportunity for additional public input from industry, academia, regulatory agencies, and the public-at-large.

ASME does not “approve,” “certify,” “rate,” or “endorse” any item, construction, proprietary device, or activity. ASME does not take any position with respect to the validity of any patent rights asserted in connection with any items mentioned in this document, and does not undertake to insure anyone utilizing a standard against liability for infringement of any applicable letters patent, nor does ASME assume any such liability. Users of a code or standard are expressly advised that determination of the validity of any such patent rights, and the risk of infringement of such rights, is entirely their own responsibility.

Participation by federal agency representatives or persons affiliated with industry is not to be interpreted as government or industry endorsement of this code or standard.

ASME accepts responsibility for only those interpretations of this document issued in accordance with the established ASME procedures and policies, which precludes the issuance of interpretations by individuals.

The endnotes and preamble in this document (if any) are part of this American National Standard.



ASME Collective Membership Mark

“ASME” and the above ASME symbol are registered trademarks of The American Society of Mechanical Engineers.

No part of this document may be reproduced in any form,  
in an electronic retrieval system or otherwise,  
without the prior written permission of the publisher.

The American Society of Mechanical Engineers  
Two Park Avenue, New York, NY 10016-5990

Copyright © 2023 by  
THE AMERICAN SOCIETY OF MECHANICAL ENGINEERS  
All rights reserved  
Printed in U.S.A.

# CONTENTS

|   |  |           |
|---|--|-----------|
| Foreword . . . . .                              |  | x         |
| Committee Roster . . . . .                      |  | xi        |
| Correspondence With the B31 Committee . . . . . |  | xiii      |
| Introduction . . . . .                          |  | xv        |
| Summary of Changes . . . . .                    |  | xvii      |
| <b>Part GR</b>                                  | <b>General Requirements . . . . .</b>                                  | <b>1</b>  |
| <b>Chapter GR-1</b>                             | <b>Scope and Definitions . . . . .</b>                                 | <b>1</b>  |
| GR-1.1  | Scope . . . . .  | 1         |
| GR-1.2  | Responsibilities . . . . .   | 1         |
| GR-1.3  | Intent of the Code . . . . .   | 1         |
| GR-1.4  | Packaged Equipment Requirements . . . . .                              | 2         |
| GR-1.5  | Terms and Definitions . . . . .  | 2         |
| GR-1.6  | ASME B31.12 Appendices . . . . .                                       | 11        |
| GR-1.7  | Nomenclature . . . . .   | 12        |
| <b>Chapter GR-2</b>                             | <b>Materials . . . . .</b>   | <b>13</b> |
| GR-2.1  | General Requirements . . . . .   | 13        |
| GR-2.2  | Joining and Auxiliary Materials . . . . .                              | 26        |
| <b>Chapter GR-3</b>                             | <b>Welding, Brazing, Heat Treating, Forming, and Testing . . . . .</b> | <b>27</b> |
| GR-3.1  | General . . . . .  | 27        |
| GR-3.2  | Welding and Brazing . . . . .  | 27        |
| GR-3.3  | Welding and Brazing Materials . . . . .                                | 30        |
| GR-3.4  | Construction of Weldments . . . . .                                    | 30        |
| GR-3.5  | Preheating for Weldments . . . . .                                     | 44        |
| GR-3.6  | Heat Treatment . . . . .   | 45        |
| GR-3.7  | Specific and Alternative Heat Treat Requirements . . . . .             | 47        |
| GR-3.8  | Construction of Brazements . . . . .                                   | 47        |
| GR-3.9  | Forming of Pipe Components . . . . .                                   | 49        |
| GR-3.10   | Hardness Testing . . . . .   | 50        |
| <b>Chapter GR-4</b>                             | <b>Inspection, Examination, and Testing . . . . .</b>                  | <b>52</b> |
| GR-4.1  | General . . . . .  | 52        |
| GR-4.2  | Inspection . . . . .   | 52        |
| GR-4.3  | Examination . . . . .  | 52        |
| GR-4.4  | Personnel Qualification and Certification . . . . .                    | 53        |
| GR-4.5  | Extent of Required Examination and Testing . . . . .                   | 54        |
| GR-4.6  | Acceptance Criteria . . . . .  | 54        |
| GR-4.7  | Supplementary Examination . . . . .                                    | 54        |
| GR-4.8  | Examinations to Resolve Uncertainty . . . . .                          | 54        |
| GR-4.9  | Defective Components and Workmanship . . . . .                         | 54        |



|                     |  |           |
|---------------------|--|-----------|
| GR-4.10             | Progressive Sampling for Examination . . . . .   | 54        |
| GR-4.11             | Testing . . . . .  | 54        |
| GR-4.12             | Records . . . . .  | 54        |
| GR-4.13             | NDE Definitions . . . . .  | 54        |
| <b>Chapter GR-5</b> | <b>Operation and Maintenance . . . . .</b>   | <b>56</b> |
| GR-5.1              | General . . . . .  | 56        |
| GR-5.2              | Operation and Maintenance Plan . . . . .   | 56        |
| GR-5.3              | Maintenance Requirements . . . . .   | 58        |
| GR-5.4              | Leakage Surveys . . . . .  | 60        |
| GR-5.5              | Repair Procedures . . . . .  | 60        |
| GR-5.6              | Injurious Dents and Mechanical Damage . . . . .  | 61        |
| GR-5.7              | Permanent Repair of Welds With Defects . . . . .   | 62        |
| GR-5.8              | Permanent Field Repair of Leaks and Nonleaking Corroded Areas . . . . .  | 62        |
| GR-5.9              | Permanent Field Repair of Hydrogen Stress Cracking in Hard Spots and Stress Corrosion<br>Cracking . . . . .        | 62        |
| GR-5.10             | Testing and Examination of Repairs . . . . .   | 62        |
| GR-5.11             | Valve Maintenance . . . . .  | 63        |
| GR-5.12             | Transmission Pipeline Maintenance . . . . .  | 63        |
| GR-5.13             | Abandoning of Transmission Facilities . . . . .  | 64        |
| GR-5.14             | Decommissioning of Transmission Facilities . . . . .   | 64        |
| GR-5.15             | Recommissioning of Transmission Facilities . . . . .   | 64        |
| GR-5.16             | Repositioning a Pipeline in Service . . . . .  | 64        |
| GR-5.17             | Testing for Integrity Assessment of In-Service Pipelines . . . . .   | 65        |
| GR-5.18             | Distribution Pipeline Maintenance . . . . .  | 66        |
| GR-5.19             | Leakage Surveys . . . . .  | 66        |
| GR-5.20             | Leakage Investigation and Action . . . . .   | 66        |
| GR-5.21             | Repair, Testing, and Examination of Mains Operating at Hoop Stress Levels at or Above 30%<br>of the SMYS . . . . . | 67        |
| GR-5.22             | Requirements for Abandoning, Disconnecting, and Reinstating Distribution Facilities . . .                          | 67        |
| GR-5.23             | Maintenance of Specific Facilities . . . . .   | 68        |
| <b>Chapter GR-6</b> | <b>Quality System Program for Hydrogen Piping and Pipeline Systems . . . . .</b>                                   | <b>70</b> |
| GR-6.1              | Quality System Program for Industrial Piping . . . . .   | 70        |
| GR-6.2              | Quality System Program for Pipelines . . . . .   | 70        |
| <b>Part IP</b>      | <b>Industrial Piping . . . . .</b>   | <b>71</b> |
| <b>Chapter IP-1</b> | <b>Scope and Responsibilities . . . . .</b>  | <b>71</b> |
| IP-1.1              | Scope . . . . .  | 71        |
| IP-1.2              | Responsibilities . . . . .   | 71        |
| IP-1.3              | Intent . . . . .   | 71        |
| IP-1.4              | Determining Code Requirements . . . . .  | 71        |
| <b>Chapter IP-2</b> | <b>Design Conditions and Criteria . . . . .</b>  | <b>72</b> |
| IP-2.1              | Design Conditions . . . . .  | 72        |
| IP-2.2              | Design Criteria . . . . .  | 73        |
| <b>Chapter IP-3</b> | <b>Pressure Design of Piping Components . . . . .</b>  | <b>79</b> |
| IP-3.1              | General . . . . .  | 79        |
| IP-3.2              | Straight Pipe . . . . .  | 79        |
| IP-3.3              | Curved and Mitered Segments of Pipe . . . . .  | 80        |

|                     |  |            |
|---------------------|--|------------|
| IP-3.4              | Branch Connections . . . . .                                   | 81         |
| IP-3.5              | Closures . . . . .   | 87         |
| IP-3.6              | Pressure Design of Flanges and Blanks . . . . .                | 88         |
| IP-3.7              | Reducers . . . . .   | 88         |
| IP-3.8              | Pressure Design of Other Components . . . . .                  | 88         |
| <b>Chapter IP-4</b> | <b>Service Requirements for Piping Components . . . . .</b>    | <b>91</b>  |
| IP-4.1              | Valves and Specialty Components . . . . .                      | 91         |
| IP-4.2              | Bolting and Tapped Holes for Components . . . . .              | 91         |
| <b>Chapter IP-5</b> | <b>Service Requirements for Piping Joints . . . . .</b>        | <b>92</b>  |
| IP-5.1              | Scope . . . . .  | 92         |
| IP-5.2              | Welded Joints . . . . .  | 92         |
| IP-5.3              | Flanged Joints . . . . .                                       | 92         |
| IP-5.4              | Expanded Joints . . . . .                                      | 93         |
| IP-5.5              | Threaded Joints . . . . .                                      | 94         |
| IP-5.6              | Caulked Joints . . . . .                                       | 94         |
| IP-5.7              | Brazed and Soldered Joints . . . . .                           | 95         |
| IP-5.8              | Special Joints . . . . .                                       | 95         |
| <b>Chapter IP-6</b> | <b>Flexibility and Support . . . . .</b>                       | <b>96</b>  |
| IP-6.1              | Analysis of Displacement Loads . . . . .                       | 96         |
| IP-6.2              | Analysis of Sustained Loads . . . . .                          | 96         |
| IP-6.3              | Piping Support . . . . .                                       | 96         |
| <b>Chapter IP-7</b> | <b>Specific Piping Systems . . . . .</b>                       | <b>97</b>  |
| IP-7.1              | Instrument Piping . . . . .                                    | 97         |
| IP-7.2              | Pressure-Relieving Systems . . . . .                           | 97         |
| <b>Chapter IP-8</b> | <b>Dimensions and Ratings of Components . . . . .</b>          | <b>98</b>  |
| IP-8.1              | Dimensional Requirements . . . . .                             | 98         |
| IP-8.2              | Ratings of Components . . . . .                                | 98         |
| IP-8.3              | Reference Documents . . . . .                                  | 98         |
| <b>Chapter IP-9</b> | <b>Fabrication, Erection, and Assembly . . . . .</b>           | <b>101</b> |
| IP-9.1              | General . . . . .  | 101        |
| IP-9.2              | Responsibility . . . . .                                       | 101        |
| IP-9.3              | Content and Coverage . . . . .                                 | 101        |
| IP-9.4              | Packaged Equipment Piping . . . . .                            | 101        |
| IP-9.5              | Exclusions . . . . .   | 101        |
| IP-9.6              | Fabrication and Erection . . . . .                             | 101        |
| IP-9.7              | Construction of Weldments . . . . .                            | 101        |
| IP-9.8              | Preheating for Weldments . . . . .                             | 102        |
| IP-9.9              | Heat Treatment . . . . .                                       | 102        |
| IP-9.10             | Specific and Alternative Heat Treatment Requirements . . . . . | 102        |
| IP-9.11             | Construction of Brazements . . . . .                           | 102        |
| IP-9.12             | Bending and Forming of Pipe and Tube . . . . .                 | 102        |
| IP-9.13             | Assembly and Erection . . . . .                                | 103        |
| IP-9.14             | Threaded Joints . . . . .                                      | 103        |
| IP-9.15             | Tubing Joints . . . . .  | 103        |
| IP-9.16             | Expanded Joints and Special Joints . . . . .                   | 103        |

|                      |   |            |
|----------------------|---|------------|
| IP-9.17              | Pipe Attachments and Supports . . . . .   | 103        |
| IP-9.18              | Cleaning of Piping . . . . .  | 103        |
| <b>Chapter IP-10</b> | <b>Inspection, Examination, and Testing . . . . .</b>   | <b>105</b> |
| IP-10.1              | Scope . . . . .   | 105        |
| IP-10.2              | Responsibility . . . . .  | 105        |
| IP-10.3              | Inspections by Owner’s Inspector . . . . .  | 105        |
| IP-10.4              | Examination Requirements . . . . .  | 105        |
| IP-10.5              | Testing . . . . .   | 109        |
| IP-10.6              | Hydrostatic Leak Test . . . . .   | 111        |
| IP-10.7              | Pneumatic Leak Test . . . . .   | 111        |
| IP-10.8              | Hydrostatic-Pneumatic Leak Test . . . . .   | 112        |
| IP-10.9              | Sensitive Leak Test . . . . .   | 112        |
| IP-10.10             | Alternative Leak Test . . . . .   | 112        |
| IP-10.11             | Mechanical and Metallurgical Testing . . . . .  | 112        |
| IP-10.12             | Records of Testing . . . . .  | 112        |
| <b>Part PL</b>       | <b>Pipelines . . . . .</b>  | <b>113</b> |
| <b>Chapter PL-1</b>  | <b>Scope and Exclusions . . . . .</b>   | <b>113</b> |
| PL-1.1               | Scope . . . . .   | 113        |
| PL-1.2               | Content and Coverage . . . . .  | 113        |
| PL-1.3               | Exclusions . . . . .  | 113        |
| <b>Chapter PL-2</b>  | <b>Pipeline Systems Components and Fabrication Details . . . . .</b>                                | <b>114</b> |
| PL-2.1               | Purpose . . . . .   | 114        |
| PL-2.2               | Piping System Components . . . . .  | 114        |
| PL-2.3               | Reinforcement of Fabricated Branch Connections . . . . .  | 116        |
| PL-2.4               | Multiple Openings and Extruded Outlets . . . . .  | 118        |
| PL-2.5               | Expansion and Flexibility . . . . .   | 119        |
| PL-2.6               | Design for Longitudinal Stress . . . . .  | 119        |
| PL-2.7               | Supports and Anchorage for Exposed Piping . . . . .   | 122        |
| PL-2.8               | Anchorage for Buried Piping . . . . .   | 122        |
| <b>Chapter PL-3</b>  | <b>Design, Installation, and Testing . . . . .</b>  | <b>124</b> |
| PL-3.1               | Provisions for Design . . . . .   | 124        |
| PL-3.2               | Buildings Intended for Human Occupancy . . . . .  | 124        |
| PL-3.3               | Considerations Necessary for Concentrations of People in Location Class 1 or Class 2 . . . . .      | 125        |
| PL-3.4               | Intent . . . . .  | 125        |
| PL-3.5               | Risk Assessment . . . . .   | 126        |
| PL-3.6               | Location Class and Changes in Number of Buildings Intended for Human Occupancy . . . . .            | 126        |
| PL-3.7               | Steel Pipeline . . . . .  | 128        |
| PL-3.8               | Hot Taps . . . . .  | 135        |
| PL-3.9               | Precautions to Prevent Combustion of Hydrogen-Air Mixtures During Construction Operations . . . . . | 135        |
| PL-3.10              | Testing After Construction . . . . .  | 136        |
| PL-3.11              | Commissioning of Facilities . . . . .   | 137        |
| PL-3.12              | Pipe-Type and Bottle-Type Holders . . . . .   | 137        |
| PL-3.13              | Control and Limiting of Hydrogen Gas Pressure . . . . .   | 138        |
| PL-3.14              | Upgrading . . . . .   | 140        |

|         |   |     |
|---------|---|-----|
| PL-3.15 | Valves . . . . .  | 141 |
| PL-3.16 | Vault Provisions for Design, Construction, and Installation of Pipeline Components . . . .                                    | 142 |
| PL-3.17 | Location for Customers' Meter and Regulator Installations . . . . .   | 143 |
| PL-3.18 | Hydrogen Gas Service Lines . . . . .  | 143 |
| PL-3.19 | Installation Inspection . . . . .   | 144 |
| PL-3.20 | Repair or Removal of Defective Welds in Piping Intended to Operate at Hoop Stress Levels of 20% or More of the SMYS . . . . . | 146 |
| PL-3.21 | Steel Pipeline Service Conversions . . . . .  | 146 |

**Mandatory Appendices**

|     |   |     |
|-----|---|-----|
| I   | Design of Aboveground Hydrogen Gas Pipeline Facilities . . . . .                            | 148 |
| II  | Reference Standards . . . . .   | 153 |
| III | Safeguarding . . . . .  | 156 |
| IV  | Nomenclature . . . . .  | 158 |
| VII | Gas Leakage and Control Criteria . . . . .  | 163 |
| IX  | Allowable Stresses and Quality Factors for Metallic Piping, Pipeline, and Bolting Materials | 168 |

**Nonmandatory Appendices**

|   |  |     |
|---|--|-----|
| A | Precautionary Considerations . . . . .   | 218 |
| B | Alternative Rules for Evaluating Stress Range . . . . .  | 228 |
| C | Recommended Practices for Proof Testing of Pipelines in Place . . . . .  | 230 |
| D | Estimating Strain in Dents . . . . .   | 233 |
| E | Sample Calculations for Branch Reinforcement in Piping . . . . .   | 234 |
| F | Welded Branch Connections and Extruded Headers in Pipeline Systems . . . . .   | 239 |
| G | Guideline for Higher Fracture Toughness Steel in Gaseous Hydrogen Service for Pipelines and Piping Systems . . . . . | 245 |

**Figures**

|            |  |    |
|------------|--|----|
| GR-2.1.2-1 | Minimum Temperatures Without Impact Testing for Carbon Steel Materials . . . . .                         | 18 |
| GR-2.1.2-2 | Reduction in Minimum Design Metal Temperature Without Impact Testing . . . . .                           | 21 |
| GR-3.4.3-1 | Geometry of Weld Joint Detail Single Vee Groove Butt With Extended Land . . . . .                        | 32 |
| GR-3.4.3-2 | Geometry of Weld Joint Detail Square Butt Weld . . . . .   | 32 |
| GR-3.4.3-3 | Geometry of Weld Joint Detail Single Vee Groove Butt, Open Root . . . . .                                | 32 |
| GR-3.4.3-4 | Unequal Pipe Component Thicknesses, Thicker Components Bored for Alignment . . . . .                     | 33 |
| GR-3.4.3-5 | Unequal Pipe Component Thicknesses, Thicker Components Taper-Bored to Align . . . . .                    | 33 |
| GR-3.4.3-6 | Geometry of Weld Joint Detail Single Vee Groove Butt, Continuous Flat Backing Ring . . . . .             | 33 |
| GR-3.4.3-7 | Geometry of Weld Joint Detail Single Vee Groove Butt, Continuous Tapered Backing Ring . . . . .          | 34 |
| GR-3.4.3-8 | Geometry of Weld Joint Detail Single Vee Groove Butt, Consumable Insert . . . . .                        | 34 |
| GR-3.4.3-9 | Preparation and Alignment of Pipe Branch to Pipe Header Connection . . . . .                             | 34 |
| GR-3.4.4-1 | Geometry of Weld Deposit Single Vee Groove Butt, Open Root . . . . .                                     | 36 |
| GR-3.4.4-2 | Geometry of Weld Deposit Root Single Vee Groove Butt With Extended Land (Without Filler Metal) . . . . . | 36 |
| GR-3.4.4-3 | Geometry of Weld Deposit Square Butt End (Without Filler Metal) . . . . .                                | 36 |
| GR-3.4.5-1 | Welding End Transition — Maximum Envelope . . . . .  | 37 |
| GR-3.4.6-1 | Geometry of Weld Deposit Single Vee Groove Butt, Open Root With Concavity . . . . .                      | 38 |
| GR-3.4.7-1 | Fillet Weld Size . . . . .   | 40 |

|            |  |     |
|------------|--|-----|
| GR-3.4.7-2 | Typical Details for Double-Welded Slip-On Flanges . . . . .  | 40  |
| GR-3.4.7-3 | Minimum Welding Dimensions for Socket Welding Components to Pipe Including Fit-Up Detail . . . . . | 41  |
| GR-3.4.9-1 | Typical Welded Branch Connections . . . . .  | 41  |
| GR-3.4.9-2 | Acceptable Details for Pipe Branch Attachment Welds . . . . .                                      | 42  |
| GR-3.4.9-3 | Acceptable Detail for Branch Connection of Pipe Fitting . . . . .                                  | 43  |
| GR-3.4.9-4 | Acceptable Details for Branch Attachment Suitable for 100% Radiography . . . . .                   | 43  |
| GR-3.8-1   | Joints for Tubular Components . . . . .  | 48  |
| GR-3.10-1  | Location of Vickers Hardness Indentations . . . . .  | 51  |
| IP-3.3.1-1 | Nomenclature for Pipe Bends . . . . .  | 80  |
| IP-3.3.3-1 | Nomenclature for Miter Bends . . . . .   | 80  |
| IP-3.4.2-1 | Branch Connection Nomenclature . . . . .   | 83  |
| IP-3.4.3-1 | Extruded Outlet Header Nomenclature . . . . .  | 85  |
| IP-3.6.3-1 | Blanks . . . . .   | 89  |
| IP-9.14-1  | Typical Threaded Joints Using Straight Threads . . . . .   | 104 |
| A-3.5-1    | Weld Quality Illustrations for Autogenous Welded Pipe or Tube . . . . .                            | 223 |
| D-1-1      | Method for Estimating Strain in Dents . . . . .  | 233 |
| E-2-1      | Illustrations for Examples in Nonmandatory Appendix E . . . . .                                    | 235 |
| F-1-1      | . . . . .  | 240 |
| F-1-2      | . . . . .  | 240 |
| F-1-3      | . . . . .  | 241 |
| F-1-4      | . . . . .  | 241 |
| F-2.1-1    | . . . . .  | 242 |
| F-2.1.5-1  | . . . . .  | 243 |
| F-2.2-1    | . . . . .  | 244 |

**Tables**

|               |   |     |
|---------------|---|-----|
| GR-2.1.1-1    | Material Specification Index for Piping and Pipe Components . . . . .                               | 14  |
| GR-2.1.1-2    | Material Specification Index for Pipelines . . . . .  | 16  |
| GR-2.1.2-1    | Requirements for Low Temperature Toughness Tests for Metals . . . . .                               | 17  |
| GR-2.1.2-2    | Tabular Values for Minimum Temperatures Without Impact Testing for Carbon Steel Materials . . . . . | 19  |
| GR-2.1.3-1    | Impact Testing Requirements for Metals . . . . .  | 22  |
| GR-2.1.3-2    | Charpy Impact Test Temperature Reduction . . . . .  | 23  |
| GR-2.1.3-3    | Minimum Required Charpy V-Notch Impact Values . . . . .   | 24  |
| GR-3.4.6-1    | Weld Reinforcement . . . . .  | 38  |
| GR-3.5-1      | Preheat Temperatures . . . . .  | 44  |
| GR-3.6.1-1    | Requirements for Postweld Heat Treatment of Weldments . . . . .                                     | 45  |
| GR-3.10-1     | Hardness Testing Acceptance Criteria . . . . .  | 50  |
| IP-2.2.8-1    | Increased Casting Quality Factors, $E_c$ . . . . .  | 76  |
| IP-2.2.8-2    | Acceptance Levels for Castings . . . . .  | 77  |
| IP-2.2.9-1    | Longitudinal Weld Joint Quality Factor, $E_j$ . . . . .   | 78  |
| IP-3.2-1      | Values of Coefficient $Y$ for $t < D/6$ . . . . .   | 79  |
| IP-3.5-1      | ASME BPVC, Section VIII, Division 1 References for Closures . . . . .                               | 87  |
| IP-8.1.1-1    | Component Standards . . . . .   | 99  |
| IP-10.4.2.2-1 | Required Nondestructive Examinations Other Than VT . . . . .  | 106 |

|             |   |     |
|-------------|---|-----|
| IP-10.4.3-1 | Acceptance Criteria for Weldments and Methods for Evaluating Weld Imperfections . . .           | 107 |
| IP-10.4.3-2 | Hardness Testing Acceptance Criteria for Weldments . . . . .                                    | 108 |
| IP-10.4.3-3 | Criterion Value Notes for Table IP-10.4.3-1 . . . . .   | 108 |
| PL-2.3.2-1  | Reinforcement of Fabricated Branch Connections, Special Requirements . . . . .                  | 118 |
| PL-2.5.2-1  | Thermal Expansion of Carbon and Low Alloy Steel . . . . .                                       | 119 |
| PL-2.5.5-1  | Modulus of Elasticity for Carbon and Low Alloy Steel . . . . .                                  | 120 |
| PL-3.6.1-1  | Location Class . . . . .  | 126 |
| PL-3.7.1-1  | Basic Design Factor, $F$ (Used With Option A) . . . . .   | 128 |
| PL-3.7.1-2  | Basic Design Factor, $F$ (Used With Option B) . . . . .   | 129 |
| PL-3.7.1-3  | Temperature Derating Factor, $T$ , for Steel Pipe . . . . .                                     | 129 |
| PL-3.7.1-4  | Nominal Chemical Composition Within a Specification/Grade . . . . .                             | 130 |
| PL-3.7.1-5  | Material Constants for Fatigue Crack Growth Rate, $da/dN$ . . . . .                             | 131 |
| PL-3.7.1-6  | Design Factors for Steel Pipe Construction (Used With Option A) . . . . .                       | 132 |
| PL-3.7.1-7  | Design Factors for Steel Pipe Construction (Used With Option B) . . . . .                       | 132 |
| PL-3.7.5-1  | Maximum Degree of Bending . . . . .   | 134 |
| VII-5.3-1   | Leak Classification and Action Criteria: Grade 1 . . . . .                                      | 166 |
| VII-5.3-2   | Leak Classification and Action Criteria: Grade 2 . . . . .                                      | 166 |
| VII-5.3-3   | Leak Classification and Action Criteria: Grade 3 . . . . .                                      | 167 |
| IX-1A       | Basic Allowable Stresses in Tension for Metal Piping Materials . . . . .                        | 170 |
| IX-1B       | SMYS for Steel Pipe Commonly Used in Pipeline Systems . . . . .                                 | 201 |
| IX-2        | Basic Casting Quality Factors, $E_c$ . . . . .  | 202 |
| IX-3A       | Basic Quality Factors for Longitudinal Weld Joints in Pipes, Tubes, and Fittings, $E_j$ . . . . | 203 |
| IX-3B       | Longitudinal Joints Factors for Pipeline Materials . . . . .                                    | 206 |
| IX-4        | Design Stress Values for Bolting Materials . . . . .  | 208 |
| IX-5A       | Carbon Steel Pipeline Materials Performance Factor, $H_f$ . . . . .                             | 217 |
| IX-5B       | Carbon Steel Piping Materials Performance Factor, $M_f$ . . . . .                               | 217 |
| IX-5C       | Low and Intermediate Alloy Steels Performance Factor, $M_f$ . . . . .                           | 217 |
| A-2-1       | Materials Compatible With Hydrogen Service . . . . .  | 219 |

# FOREWORD

Responding to an evident need and at the request of The American Society of Mechanical Engineers (ASME), the American Standards Association initiated Project B31 in March 1926, with ASME as sole administrative sponsor. The breadth of the field involved required that membership of the Sectional Committee be drawn from some 40 engineering societies, industries, government bureaus, institutes, and trade associations.

The initial publication in 1935 was the American Tentative Standard Code for Pressure Piping. Revisions from 1942 through 1955 were published as the American Standard Code for Pressure Piping, ASA B31.1. Then it was decided that the various industry sections, beginning with ASA B31.8-1955, Gas Transmission and Distribution Piping Systems, be published as separate documents. The first Petroleum Refinery Piping Code Section was designated ASA B31.3-1959. ASA B31.3 revisions were published in 1962 and 1966. Between 1967 and 1969, the American Standards Association became first the United States of America Standards Institute, then the American National Standards Institute. The Sectional Committee became American National Standards Committee B31, and the Code was renamed the American National Standard Code for Pressure Piping. The next B31.3 revision was designated ANSI B31.3-1973. Addenda were published through 1975. The Standards Committee was reorganized in 1978 as a Committee operating under ASME procedures with ANSI accreditation. It is now the ASME Code for Pressure Piping, B31 Committee. The Section committee structure remains essentially unchanged.

As a result of preliminary studies, it was concluded that gaps exist between existing piping and pipeline codes and standards, and hydrogen infrastructure applications. A Project Team was formed under the ASME B31 Standards Committee to develop a new B31.12 Code for hydrogen piping and pipelines. The Project Team was subsequently restructured under the B31 Standards Committee as a Section Committee.

Since the first edition, the B31.12 Code has applied to design, construction, operation, and maintenance requirements for piping, pipelines, and distribution systems in hydrogen service. Typical applications are power generation, process plants, refining, transportation, distribution, and automotive filling stations. This Code is composed of [Part GR](#), General Requirements, including common requirements referenced by all other parts; [Part IP](#), Industrial Piping; and [Part PL](#), Pipelines, including distribution systems. These Parts incorporate information specific to hydrogen service and either reference or incorporate applicable parts of ASME B31.3, Process Piping; ASME B31.1, Power Piping; ASME B31.8, Gas Transmission and Distribution Piping Systems; ASME B31.8S, Managing System Integrity of Gas Pipelines; and Section VIII, Division 3 of the ASME Boiler and Pressure Vessel Code, where appropriate.

Material performance factors have been included to account for the adverse effects of hydrogen gas on the mechanical properties of carbon and low alloy steels operating within the hydrogen embrittlement range. Many materials included in ASME B31.3 have been omitted from ASME B31.12 tables due to their unsuitability for hydrogen service. Rules have been added for conversion or retrofit of existing pipeline and distribution systems from natural gas or petroleum to hydrogen service. Parts covering commercial, residential, and nonmetallic systems will be added in future editions. Material performance factors will be reevaluated as materials research data are developed and understanding of hydrogen embrittlement of carbon and low alloy steels increases.

ASME B31.12-2008 was approved by the American National Standards Institute on December 3, 2008.

ASME B31.12-2011 was approved by the American National Standards Institute on June 7, 2011.

ASME B31.12-2014 was approved by the American National Standards Institute on October 24, 2014.

ASME B31.12-2019 was approved by the American National Standards Institute on March 19, 2019.

ASME B31.12-2023 was approved by the American National Standards Institute on August 24, 2023.

# ASME B31 COMMITTEE

## Code for Pressure Piping

(The following is the roster of the committee at the time of approval of this Code.)

### STANDARDS COMMITTEE OFFICERS

**W. H. Eskridge**, *Chair*  
**K. A. Vilminot**, *Vice Chair*  
**J. Oh**, *Secretary*

### STANDARDS COMMITTEE PERSONNEL

|   |   |
|---|---|
| <b>D. Anderson</b> , Consultant                                   | <b>G. A. Jolly</b> , Samshin, Ltd.                            |
| <b>R. J. T. Appleby</b> , Consultant                              | <b>K. Kaplan</b> , Consultant                                 |
| <b>K. C. Bodenhamer</b> , TRC Pipeline Services                   | <b>W. J. Mauro</b> , Consultant                               |
| <b>R. Bojarczuk</b> , Retired                                     | <b>J. E. Meyer</b> , CDM Smith — Industrial Division          |
| <b>M. R. Braz</b> , MRBraz & Associates, PLLC                     | <b>T. Monday</b> , Team Industries, Inc.                      |
| <b>M. Burkhardt</b> , The Burkhardt Group, Inc.                   | <b>J. Oh</b> , The American Society of Mechanical Engineers   |
| <b>R. Campbell</b> , Bechtel                                      | <b>W. Olson</b> , Gulf Interstate Engineering                 |
| <b>J. Caylor</b> , Caylor Engineering & Associates, PLLC          | <b>D. W. Raho</b> , CCM 2000                                  |
| <b>J. S. Chin</b> , TC Energy                                     | <b>M. Rana</b> , Consultant                                   |
| <b>D. D. Christian</b> , Victaulic                                | <b>R. Reamey</b> , Turner Industries Group, LLC               |
| <b>R. P. Deubler</b> , Becht                                      | <b>M. J. Rosenfeld</b> , RSI Pipeline Solutions, LLC          |
| <b>M. Engelkemier</b> , Cargill                                   | <b>J. Schmitz</b> , Southwest Gas Corp.                       |
| <b>W. H. Eskridge, Jr.</b> , Becht                                | <b>S. K. Sinha</b> , SOCOTEC Engineering, Inc.                |
| <b>D. J. Fetzner</b> , Retired                                    | <b>W. J. Sperko</b> , Sperko Engineering Services, Inc.       |
| <b>D. R. Frikken</b> , Becht                                      | <b>F. W. Tatar</b> , Consultant                               |
| <b>R. A. Grichuk</b> , S&B Engineers and Constructors, Ltd.       | <b>K. A. Vilminot</b> , Commonwealth Associates, Inc.         |
| <b>R. W. Haupt</b> , Pressure Piping Engineering Associates, Inc. | <b>M. L. Nayyar</b> , <i>Contributing Member</i> , Consultant |

### B31.12 HYDROGEN PIPING AND PIPELINES SECTION COMMITTEE

|   |   |
|---|---|
| <b>M. Rana</b> , <i>Chair</i> , Consultant  | <b>J. H. Robertson</b> , J. H. Robertson Co.                        |
| <b>K. Xu</b> , <i>Vice Chair</i> , Praxair, Inc.                                    | <b>P. D. Robertson</b> , J. H. Robertson Co.                        |
| <b>R. Rahaman</b> , <i>Secretary</i> , The American Society of Mechanical Engineers | <b>A. Slifka</b> , National Institute of Standards and Technology   |
| <b>P. Bortot, Sr.</b> , TenarisDalmine  | <b>H. Solanky</b> , SGT, Inc.                                       |
| <b>C. J. Campbell</b> , Consultant  | <b>W. J. Sperko</b> , Sperko Engineering Services, Inc.             |
| <b>W. P. Collins</b> , WPC Sol, LLC   | <b>D. G. Stalheim</b> , DGS Metallurgical Solutions, Inc.           |
| <b>D. R. Frikken</b> , Becht  | <b>G. K. Vinjamuri</b> , Consultant                                 |
| <b>K. Grisham</b> , Air Liquide America, LP   | <b>R. L. Amaro</b> , <i>Contributing Member</i> , Southern Research |
| <b>G. A. Jolly</b> , Samshin, Ltd.  | <b>A. Esmaeli</b> , <i>Contributing Member</i> , APA Group          |
|   | <b>X. Tang</b> , <i>Contributing Member</i> , Swagelok Co.          |

### B31 EXECUTIVE COMMITTEE

|  |  |
|--|--|
| <b>K. A. Vilminot</b> , <i>Chair</i> , Commonwealth Associates, Inc. | <b>D. D. Christian</b> , Victaulic             |
| <b>W. H. Eskridge, Jr.</b> , <i>Vice Chair</i> , Becht               | <b>R. P. Deubler</b> , Becht                   |
| <b>D. Anderson</b> , Consultant                                      | <b>M. Engelkemier</b> , Cargill                |
| <b>M. R. Braz</b> , MRBraz & Associates, PLLC                        | <b>D. R. Frikken</b> , Becht                   |
| <b>M. Burkhardt</b> , The Burkhardt Group, Inc.                      | <b>W. Olson</b> , Gulf Interstate Engineering  |
| <b>R. Campbell</b> , Bechtel   | <b>M. Rana</b> , Consultant                    |
| <b>J. Caylor</b> , Caylor Engineering & Associates, PLLC             | <b>S. K. Sinha</b> , SOCOTEC Engineering, Inc. |



## B31 FABRICATION AND EXAMINATION TECHNICAL COMMITTEE

**R. Campbell**, *Chair*, Bechtel  
**S. Findlan**, *Vice Chair*, Stone and Webster, Inc.  
**U. D'Urso**, *Secretary*, The American Society of Mechanical Engineers  
**B. Boseo**, Burns & McDonnell  
**P. M. Davis**, Wood Group USA, Inc.  
**M. DeLong**, IHI Energy Solutions, Inc.  
**R. Duran**, Shell USA  
**J. W. Frey**, Joe W. Frey Engineering Associates, LLC  
**D. R. Frikken**, Becht  
**S. Gingrich**, Consultant

**K. Hayes**, Consultant  
**P. Hayes**, Sinewave Solutions  
**T. Monday**, Team Industries, Inc.  
**A. D. Nalbandian**, Thielsch Engineering, Inc.  
**R. Reamey**, Turner Industries Group, LLC  
**L. Richardson**, Crossbridge Compliance, LLC  
**W. J. Sperko**, Sperko Engineering Services, Inc.  
**J. Swezy, Jr.**, Bureau Veritas Inspection and Insurance  
**K. Wu**, Stellar Energy Systems

## B31 MATERIALS TECHNICAL COMMITTEE

**R. P. Deubler**, *Chair*, Becht  
**C. Henley**, *Vice Chair*, Kiewit Engineering Group, Inc.  
**C. Rodriguez**, *Secretary*, The American Society of Mechanical Engineers  
**B. Bounds**, Bechtel Energy, Inc.  
**W. P. Collins**, Consultant  
**W. H. Eskridge, Jr.**, Becht  
**A. Esmaili**, APA Group  
**R. A. Grichuk**, S&B Engineers and Constructors, Ltd.  
**J. Gundlach**, Michigan Seamless Tube and Pipe  
**A. A. Hassan**, PGESCO

**L. Henderson, Jr.**, Kiewit Engineering Group, Inc.  
**T. Hudson**, Consultant  
**G. A. Jolly**, Samshin, Ltd.  
**C. J. Melo**, S&B Engineers and Constructors, Ltd.  
**K. Pham**, Fluor Enterprises, Inc.  
**D. W. Raho**, CCM 2000  
**R. A. Schmidt**, Canadoil  
**S. Tonkins**, BP Americas  
**D. K. Verma**, Bechtel Energy, Inc.  
**Z. Djilali**, *Contributing Member*, Sonatrach  
**M. L. Nayyar**, *Contributing Member*, Consultant

## B31 MECHANICAL DESIGN TECHNICAL COMMITTEE

**M. Engelkemier**, *Chair*, Cargill  
**D. A. Arnett**, *Vice Chair*, ExxonMobil Research and Engineering  
**R. Rahaman**, *Secretary*, The American Society of Mechanical Engineers  
**G. A. Antaki**, Becht  
**R. Bethea**, Huntington Ingalls Industries — Newport News Shipbuilding  
**D. J. Fetznner**, Retired  
**D. Fraser**, NASA Ames Research Center  
**J. A. Graziano**, Consultant  
**J. D. Hart**, SSD, Inc.

**R. W. Haupt**, Pressure Piping Engineering Associates, Inc.  
**B. P. Holbrook**, Consultant  
**R. A. Leishear**, Leishear Engineering, LLC  
**G. D. Mayers**, Serco, Inc.  
**T. Q. McCawley**, Consultant  
**J. E. Meyer**, CDM Smith — Industrial Division  
**P. Moore**, Burns & McDonnell  
**A. W. Paulin**, Paulin Research Group  
**M. J. Rosenfeld**, RSI Pipeline Solutions, LLC  
**H. Kosasayana**, *Contributing Member*, JGC Corp.

## B31 QUALIFICATION OF PIPELINE PERSONNEL TECHNICAL COMMITTEE

**M. Burkhart**, *Chair*, The Burkhart Group, Inc.  
**T. Cash**, *Vice Chair*, Enstor Gas, LLC  
**A. Carrion**, *Secretary*, The American Society of Mechanical Engineers  
**L. B. Ables**, Enterprise Products Co.  
**A. Borgmeyer**, The Mosaic Co.  
**M. J. Bradley**, TRC Companies  
**A. Chamblin**, Colonial Pipeline Co.  
**V. M. Frederick III**, Consultant  
**B. A. Heck**, Miller Pipeline, LLC  
**G. W. Isbell**, Energy Worldnet, Inc.  
**W. B. McGaughey, Jr.**, Consultant  
**T. Meek**, Veriforce, LLC  
**W. Miller**, Warren Miller Enterprises, LLC  
**D. K. Moore**, Trout Hydrodynamics, Inc.  
**L. P. Murray**, MEA Energy Association  
**G. Ochs**, U.S. DOT

**V. C. Oameh**, Public Utilities Commission of Ohio  
**K. Riddle**, Magellan Midstream Partners, LP  
**E. Rodriguez**, Consultant  
**J. Trevino**, Valero  
**J. R. Urtz**, LIUNA Training & Education Fund  
**P. Williams III**, Smith System Driver Improvement Institute, Inc.  
**M. Zanter**, State of South Dakota Public Utilities Commission  
**B. C. Barker**, *Contributing Member*, Southwest Gas Corp.  
**M. B. Borders**, *Contributing Member*, Nisource  
**E. Fonseca**, *Contributing Member*, Enterprise Products  
**J. Garland**, *Contributing Member*, EGW Utility Solutions  
**J. Langwell**, *Contributing Member*, Smith System Pinion, LLC  
**T. Messenger**, *Contributing Member*, ASTAR, Inc.  
**E. Schlaupitz**, *Contributing Member*, NCCER  
**J. Schmitz**, *Contributing Member*, Southwest Gas Corp.  
**H. Stein**, *Contributing Member*, Semco Energy Gas Co.

## CORRESPONDENCE WITH THE B31 COMMITTEE

**General.** ASME codes and standards are developed and maintained by committees with the intent to represent the consensus of concerned interests. Users of ASME codes and standards may correspond with the committees to propose revisions or cases, report errata, or request interpretations. Correspondence for this Code should be sent to the staff secretary noted on the committee's web page, accessible at <https://go.asme.org/B31committee>.

**Revisions and Errata.** The committee processes revisions to this Code on a continuous basis to incorporate changes that appear necessary or desirable as demonstrated by the experience gained from the application of the Code. Approved revisions will be published in the next edition of the Code.

In addition, the committee may post errata on the committee web page. Errata become effective on the date posted. Users can register on the committee web page to receive e-mail notifications of posted errata.

This Code is always open for comment, and the committee welcomes proposals for revisions. Such proposals should be as specific as possible, citing the paragraph number, the proposed wording, and a detailed description of the reasons for the proposal, including any pertinent background information and supporting documentation.

### Cases

(a) The most common applications for cases are

(1) to permit early implementation of a revision based on an urgent need

(2) to provide alternative requirements

(3) to allow users to gain experience with alternative or potential additional requirements prior to incorporation directly into the Code

(4) to permit the use of a new material or process

(b) Users are cautioned that not all jurisdictions or owners automatically accept cases. Cases are not to be considered as approving, recommending, certifying, or endorsing any proprietary or specific design, or as limiting in any way the freedom of manufacturers, constructors, or owners to choose any method of design or any form of construction that conforms to the Code.

(c) A proposed case shall be written as a question and reply in the same format as existing cases. The proposal shall also include the following information:

(1) a statement of need and background information

(2) the urgency of the case (e.g., the case concerns a project that is underway or imminent)

(3) the Code and the paragraph, figure, or table number

(4) the editions of the Code to which the proposed case applies

(d) A case is effective for use when the public review process has been completed and it is approved by the cognizant supervisory board. Approved cases are posted on the committee web page.

**Interpretations.** Upon request, the committee will issue an interpretation of any requirement of this Code. An interpretation can be issued only in response to a request submitted through the online Interpretation Submittal Form at <https://go.asme.org/InterpretationRequest>. Upon submitting the form, the inquirer will receive an automatic e-mail confirming receipt.

ASME does not act as a consultant for specific engineering problems or for the general application or understanding of the Code requirements. If, based on the information submitted, it is the opinion of the committee that the inquirer should seek assistance, the request will be returned with the recommendation that such assistance be obtained. Inquirers can track the status of their requests at <https://go.asme.org/Interpretations>.

ASME procedures provide for reconsideration of any interpretation when or if additional information that might affect an interpretation is available. Further, persons aggrieved by an interpretation may appeal to the cognizant ASME committee or subcommittee. ASME does not "approve," "certify," "rate," or "endorse" any item, construction, proprietary device, or activity.

Interpretations are published in the ASME Interpretations Database at <https://go.asme.org/Interpretations> as they are issued.

**Committee Meetings.** The B31 Standards Committee regularly holds meetings that are open to the public. Persons wishing to attend any meeting should contact the secretary of the committee. Information on future committee meetings can be found on the committee web page at <https://go.asme.org/B31committee>.

# INTRODUCTION

(23)

The ASME B31 Code for Pressure Piping consists of a number of individually published Sections, each an American National Standard, under the direction of ASME Committee B31, Code for Pressure Piping.

Rules for each Section reflect the kinds of piping installations considered during its development, as follows:

- B31.1 Power Piping: piping typically found in electric power-generating stations, in industrial and institutional plants, geothermal heating systems, and central and district heating and cooling systems
- B31.3 Process Piping: piping typically found in petroleum refineries; onshore and offshore petroleum and natural gas production facilities; chemical, pharmaceutical, textile, paper, ore processing, semiconductor, and cryogenic plants; food and beverage processing facilities; and related processing plants and terminals
- B31.4 Pipeline Transportation Systems for Liquids and Slurries: piping transporting products that are predominately liquid between plants and terminals and within terminals, pumping, regulating, and metering stations
- B31.5 Refrigeration Piping: piping for refrigerants and secondary coolants
- B31.8 Gas Transmission and Distribution Piping Systems: piping transporting products that are predominately gas between sources and terminals, including compressor, regulating, and metering stations; and gas-gathering pipelines
- B31.9 Building Services Piping: piping typically found in industrial, institutional, commercial, and public buildings, and in multi-unit residences, which does not require the range of sizes, pressures, and temperatures covered in B31.1
- B31.12 Hydrogen Piping and Pipelines: piping in gaseous and liquid hydrogen service, and pipelines handling gaseous hydrogen and gaseous hydrogen mixtures

This is Code Section B31.12, Hydrogen Piping and Pipelines. Hereafter, in this Introduction and in the text of this Code Section B31.12, where the word *Code* is used without specific identification, it means this Code Section.

It is the owner's responsibility to select the Code Section that most nearly applies to a proposed piping installation. Factors to be considered by the owner include limitations of the Code Section, jurisdictional requirements, and the applicability of other codes and standards. All applicable requirements of the selected Code Section shall be met. For some installations, more than one Code Section may apply to different parts of the installation. The owner is also responsible for imposing requirements supplementary to those of the selected Code Section, if necessary, to assure safe piping for the proposed installation.

Certain piping within a facility may be subject to other codes and standards, including but not limited to

- ANSI Z223.1/NFPA 54 National Fuel Gas Code: piping for fuel gas from the point of delivery to the connection of each fuel utilization device

- NFPA Fire Protection Standards: fire protection systems using water, carbon dioxide, halon, foam, dry chemicals, and wet chemicals

- NFPA 99 Health Care Facilities: medical and laboratory gas systems

- building and plumbing codes, as applicable, for potable hot and cold water, and for sewer and drain systems

The Code specifies engineering requirements deemed necessary for safe design, construction, operation, and maintenance of pressure piping. While safety is the overriding consideration, this factor alone will not necessarily govern the final specifications for any piping installation or operation. The Code is not a design handbook. Many decisions that must be made to produce a safe piping installation and to maintain system integrity are not specified in detail within this Code. The Code does not serve as a substitute for sound engineering judgment by the owner and the designer.

To the greatest possible extent, Code requirements for design are stated in terms of basic design principles and formulas. These are supplemented as necessary with specific requirements to ensure uniform application of principles and to guide selection and application of piping elements. The Code prohibits designs and practices known to be unsafe and contains warnings where caution, but not prohibition, is warranted.

This Code Section includes the following:

(a) references to acceptable material specifications and component standards, including dimensional requirements and pressure–temperature ratings

(b) requirements for design of components and assemblies, including pipe supports

(c) requirements and data for evaluation and limitation of stresses, reactions, and movements associated with pressure, temperature changes, and other forces

(d) guidance and limitations on the selection and application of materials, components, and joining methods

(e) requirements for the fabrication, assembly, and erection of piping

(f) requirements for examination, inspection, and testing of piping

ASME Committee B31 is organized and operates under procedures of The American Society of Mechanical Engineers that have been accredited by the American National Standards Institute. The Committee is a continuing one and keeps all Code Sections current with new developments in materials, construction, and industrial practice. New editions are published at intervals of 3 yr.

It is intended that this edition of Code Section B31.12 not be retroactive. Unless agreement is specifically made between contracting parties to use another issue, or the regulatory body having jurisdiction imposes the use of another issue, the latest edition issued at least 6 months prior to the original contract date for the first phase of activity covering a piping system or systems shall be the governing document for all design, materials, fabrication, erection, examination, and testing for the piping until the completion of the work and initial operation.

Materials ordinarily are listed in the stress tables only when sufficient usage in piping within the scope of the Code has been shown. Requests for listing shall include evidence of satisfactory usage and specific data to permit establishment of allowable stresses, maximum and minimum temperature limits, and other restrictions. Additional criteria can be found in the guidelines for the addition of new materials in the ASME Boiler and Pressure Vessel Code, Section II. [To develop usage and gain experience, unlisted materials may be used in accordance with [para. GR-2.1.1\(b\)](#).]

# ASME B31.12-2023

## SUMMARY OF CHANGES

Following approval by the ASME B31 Committee and ASME, and after public review, ASME B31.12-2023 was approved by the American National Standards Institute on August 24, 2023.

Mandatory Appendices V and VIII, noted as “in preparation” in previous editions, have been deleted. In addition, ASME B31.12-2023 includes the following changes identified by a margin note, **(23)**.

| <i>Page</i> | <i>Location</i>     | <i>Change</i>  |
|-------------|---------------------|--|
| xv          | Introduction        | Updated  |
| 1           | GR-1.1              | First sentence revised   |
| 16          | GR-2.1.2            | (1) In subpara. (b), first sentence added<br>(2) Subparagraph (b)(6) editorially revised |
| 14          | Table GR-2.1.1-1    | General Note (a) and Notes (2), (4), and (5) revised                                     |
| 16          | Table GR-2.1.1-2    | Revised in its entirety  |
| 18          | Figure GR-2.1.2-1   | Notes redesignated   |
| 19          | Table GR-2.1.2-2    | Notes revised  |
| 27          | GR-3.1              | Editorially revised  |
| 27          | GR-3.2              | Editorially revised  |
| 27          | GR-3.2.3            | In first paragraph, cross-reference to ASME BPVC updated                                 |
| 27          | GR-3.2.5            | Subparagraph (a)(1) editorially revised  |
| 35          | GR-3.4.4            | In subpara. (e), SI unit added   |
| 44          | Table GR-3.5-1      | Minimum preheat temperature required for carbon steel revised                            |
| 48          | GR-3.8.5            | Subparagraph (d)(1) editorially revised  |
| 50          | GR-3.9.2            | Reinstated by errata   |
| 70          | Chapter GR-6        | Revised in its entirety  |
| 71          | IP-1.1.2            | Subparagraphs (b) and (c) revised  |
| 76          | IP-2.2.10           | Subparagraphs (c) and (d) revised  |
| 93          | IP-5.3.5            | Subparagraph (c) editorially revised   |
| 96          | Chapter IP-6        | Revised in its entirety  |
| 97          | IP-7.2.3            | Footnotes renumbered   |
| 105         | IP-10.4.2           | Revised  |
| 105         | IP-10.4.2.1         | Added  |
| 105         | IP-10.4.2.2         | Added  |
| 106         | Table IP-10.4.2.2-1 | Former Table IP-10.4.2-1 revised   |
| 106         | IP-10.4.5.2         | Revised in its entirety  |
| 109         | IP-10.4.5.7         | Subparagraphs (b)(1) through (b)(3) editorially revised                                  |
| 111         | IP-10.7.2           | Revised  |
| 113         | PL-1.3              | Subparagraph (e) revised   |
| 119         | Table PL-2.5.2-1    | Revised in its entirety  |
| 119         | PL-2.5.3            | In subpara. (h), cross-reference updated   |
| 120         | Table PL-2.5.5-1    | Revised in its entirety  |

| <i>Page</i> | <i>Location</i>       | <i>Change</i>   |
|-------------|-----------------------|---|
| 120         | PL-2.6.2              | (1) In subparas. (a) through (e), units deleted<br>(2) Equation in subpara. (e) revised   |
| 121         | PL-2.6.5              | In subpara. (a), unit deleted   |
| 121         | PL-2.6.6              | In subpara. (a)(3), nomenclature revised  |
| 124         | PL-3.2.1              | SI units added  |
| 125         | PL-3.2.2              | SI units added  |
| 128         | PL-3.7.1              | Revised   |
| 129         | Table PL-3.7.1-3      | Celsius temperatures added  |
| 133         | PL-3.7.3              | In subparas. (a), (a)(1), (a)(2), and (b), SI units revised   |
| 134         | PL-3.7.5              | In subpara. (b), SI unit revised  |
| 135         | PL-3.8                | In subpara. (a), SI unit revised  |
| 136         | PL-3.10.7             | In subpara. (c), SI unit revised  |
| 137         | PL-3.12.3             | Revised   |
| 139         | PL-3.13.5             | Subparagraphs (a), (a)(1), (b), (c), (c)(1), and (c)(3) revised   |
| 143         | PL-3.18.1             | In subparas. (a), (b)(4), (b)(6), (c)(3), and (e)(2), SI units revised  |
| 144         | PL-3.18.2             | In subpara. (a)(2), SI units revised  |
| 144         | PL-3.19               | (1) Deleted and former para. PL-3.19.1 redesignated<br>(2) Title and subparas. (a) and (b)(6) revised   |
| 144         | PL-3.19.1             | Former para. PL-3.19.2 redesignated and title revised   |
| 145         | PL-3.19.2             | (1) Former para. PL-3.19.3 redesignated<br>(2) Title and first paragraph revised<br>(3) Subparagraphs (g) through (h)(11) deleted and subsequent subparagraphs redesignated |
| 145         | PL-3.19.3             | Former para. PL-3.19.4 redesignated   |
| 145         | PL-3.19.4             | Former para. PL-3.19.5 redesignated   |
| 145         | PL-3.19.5             | Former para. PL-3.19.6 redesignated   |
| 145         | PL-3.19.6             | Former para. PL-3.19.7 redesignated   |
| 146         | PL-3.19.7             | (1) Former para. PL-3.19.8 redesignated<br>(2) In subpara. (b)(2)(-c), SI unit added  |
| 146         | PL-3.21               | In subpara. (i), SI unit revised  |
| 148         | I-1.3.2.1             | In subpara. (a), SI unit revised  |
| 153         | Mandatory Appendix II | Revised   |
| 164         | VII-3.3.2             | SI units revised  |
| 164         | VII-3.5.3             | Former para. VII-3.5.2(d) redesignated  |
| 168         | IX-1                  | Subparagraph (e) revised  |
| 170         | Table IX-1A           | (1) Note (55) redesignated as Note (4)<br>(2) Notes (42) and (56) deleted   |
| 201         | Table IX-1B           | SMYS for API 5L, Grade X52, corrected by errata from 317 MPa to 359 MPa   |
| 208         | Table IX-4            | (1) Minimum temperature, °F, for stainless steel 14Cr-24Ni revised<br>(2) Note (14) redesignated as Note (3)  |
| 218         | A-2                   | Revised   |
| 218         | A-2.2                 | First paragraph revised   |
| 219         | Table A-2-1           | Revised in its entirety   |

| <i>Page</i> | <i>Location</i> | <i>Change</i>   |
|-------------|-----------------|---|
| 219         | A-2.4           | (1) Second and third paragraphs revised<br>(2) Last paragraph deleted |
| 219         | A-2.5           | Revised in its entirety   |
| 219         | A-2.6           | First paragraph revised   |
| 220         | A-2.10          | Revised in its entirety   |
| 220         | A-2.10.1        | Added   |
| 221         | A-2.13          | Added   |
| 221         | A-3.1.1         | SI unit added   |
| 222         | A-3.5           | In subpara. (d), SI unit added  |
| 223         | Figure A-3.5-1  | In illustration (f), SI unit added                                    |
| 226         | A-9.1.5         | SI units added  |
| 230         | C-1             | SI unit added   |
| 234         | E-1             | Last sentence added   |
| 239         | F-1             | First sentence added  |
| 239         | F-2.1           | Editorially revised   |



INTENTIONALLY LEFT BLANK

# PART GR

## GENERAL REQUIREMENTS

---

### Chapter GR-1

#### Scope and Definitions

##### (23) GR-1.1 SCOPE

This Code is applicable to piping and pipelines handling gaseous hydrogen and gaseous hydrogen mixtures and to piping in liquid hydrogen service. This Code is applicable up to and including the joint connecting the piping to associated pressure vessels and equipment but not to the vessels and equipment themselves. It is applicable to the location and type of support elements but not to the structure to which the support elements are attached. The design for pressure and temperature shall be in accordance with the requirements of [Part IP](#) for industrial piping and [Part PL](#) for pipelines. This Code is presented in the following parts and appendices:

(a) *Part GR — General Requirements.* [Part GR](#) contains requirements applicable to and referenced by other parts. It contains definitions and requirements for materials, welding, brazing, heat treating, forming, testing, inspection, examination, operation, and maintenance. It also contains quality system topics common to the other parts.

(b) *Part IP — Industrial Piping.* [Part IP](#) includes requirements for components, design, fabrication, assembly, erection, inspection, examination, and testing of piping.

(c) *Part PL — Pipelines.* [Part PL](#) sets forth requirements for components, design, installation, and testing of hydrogen pipelines.

(d) [Mandatory Appendices I through IX](#)

(e) [Nonmandatory Appendices A through F](#)

Each part defines requirements for piping or pipelines, as applicable, within its scope. The requirements are different for different aspects of components, design, fabrication, installation, assembly, erection, inspection, examination, and testing. It is required that each part be used in conjunction with the General Requirements section but independent of the other parts. The joint connecting piping governed by two different parts shall be subject exclusively to the requirements of one of the two parts. It is not intended that this edition of this Code be applied retroactively to existing hydrogen systems.

##### GR-1.2 RESPONSIBILITIES

###### GR-1.2.1 Owner

The owner shall have overall responsibility for compliance with this Code and for establishing the requirements for design, construction, examination, inspection, testing, operation, and maintenance of the hydrogen piping or pipeline system.

###### GR-1.2.2 Designer

The designer is responsible to the owner for assurance that the engineering design of piping or the pipeline system complies with the requirements of this Code and with any additional requirements established by the owner.

###### GR-1.2.3 Construction Organization

The construction organization of piping and pipeline systems is responsible for providing materials, components, and workmanship in compliance with the requirements of this Code and the engineering design.

###### GR-1.2.4 Owner's Inspector

The owner's Inspector is responsible to the owner to verify that all required examinations, inspections, and testing are complete. The owner's Inspector verifies that all required certifications and records have been completed. Also, the owner's Inspector is responsible for verification of the construction organization's quality systems program implementation.

##### GR-1.3 INTENT OF THE CODE

(a) It is the intent of this Code to set forth engineering requirements deemed necessary for safe design, construction, and installation of piping and pipeline systems in hydrogen service.

(b) This Code generally specifies a simplified approach for many of its requirements. A designer may choose to use a more rigorous analysis to develop design and construction requirements. When the designer decides to take this

approach, the designer shall provide to the owner details and calculations demonstrating that design, construction, examination, and testing are consistent with the design criteria of this Code. These details shall be adequate for the owner to verify the validity and shall be approved by the owner. The details shall be documented in the engineering design.

(c) Piping elements should, insofar as practicable, conform to the specifications and standards listed in this Code. Piping elements neither specifically approved nor specifically prohibited by this Code may be used, provided they are qualified for use as set forth in applicable parts of this Code.

(d) The engineering design shall specify any unusual requirements for a particular service. Where service requirements necessitate measures beyond those required by this Code, such measures shall be specified by the engineering design. Where so specified, the Code requires that they be accomplished.

(e) Code requirements include specific provisions applicable to hydrogen service. These requirements shall include, but shall not be limited to, selection and application of materials, components, and joints. Service requirements include prohibitions, limitations, and conditions, such as temperature and pressure limits or a requirement for safeguarding. Code requirements for a piping or pipeline system are established by the most restrictive requirements that apply to any element of the system.

#### GR-1.4 PACKAGED EQUIPMENT REQUIREMENTS

Also included within the scope of this Code is piping that interconnects pieces or stages within a packaged equipment assembly for piping or pipeline systems. This Code excludes the following:

(a) the exclusions specifically limited by [Part IP](#), Industrial Piping or [Part PL](#), Pipelines

(b) piping that is required to conform to another Code

(c) tubes, tube headers, crossovers, and manifolds of fired heaters that are internal to the heater enclosure

(d) power boilers, pressure vessels, heat exchangers, pumps, compressors, and other fluid handling or processing equipment, including internal piping and connections for external piping

#### GR-1.5 TERMS AND DEFINITIONS

Some of the terms relating to piping components and the fabrication and erection of piping and pipeline systems are found in this paragraph. For additional terms relating to

(a) welding and brazing, see ASME Boiler and Pressure Vessel Code (BPVC), Section IX or AWS Standard A3.0

(b) nondestructive examination, see ASME BPVC, Section V

(c) materials, see ASME BPVC, Section II, Parts A, B, and D

(d) welding materials, see ASME BPVC, Section II, Part C  
*alloy steel*: steel to which one or more alloying elements other than carbon have been deliberately added (e.g., chromium, nickel, molybdenum) to achieve a particular physical property.

*ambient temperature*: temperature of the surrounding medium, usually used to refer to the temperature of the air in which a structure is situated or a device operates.

*anneal heat treatment*: heating to and holding at a suitable temperature and then cooling at a suitable rate for such purposes as reducing hardness, improving machinability, facilitating cold working, producing a desired microstructure, or obtaining desired mechanical, physical, or other properties.

*anode*: electrode of an electrochemical cell at which oxidation occurs. Electrons flow away from the anode in the external circuit. Corrosion usually occurs, and metal ions enter the solution at the anode.

*arc cutting*: group of cutting processes wherein the severing or removing of metals is affected by melting with the heat of an arc between an electrode and the base metal (includes carbon-arc cutting, metal-arc cutting, gas metal-arc cutting, gas tungsten-arc cutting, plasma-arc cutting, and air carbon-arc cutting). See also *oxygen-arc cutting (OAC)*.

*arc welding*: group of welding processes wherein coalescence is produced by heating with an electric arc or arcs, with or without the application of pressure and with or without the use of filler metal.

*assembly*: joining together of two or more piping components by bolting, welding, screwing, brazing, or use of packing devices as specified by the engineering design.

*autogenous welding*: fusion welding method using heat to join two pieces of metal without the addition of filler metal.

*automatic welding*: welding with equipment that performs the welding operation without adjustment of the controls by an operator.

*backfill*: material placed in a hole to fill the space around the anodes, vent pipe, and buried components of a cathodic protection system.

*backing ring*: material in the form of a ring used to support molten weld metal.

*base material*: material of the piping component, plate, or other metallic products.

*basic allowable stress, S*: stress value for any material determined by the appropriate stress basis found in this Code.

*bolt design stress*: stress used to determine the required cross-sectional area of bolts in a bolted joint.

*brazement*: assembly whose component parts are joined by brazing.

*brazing*: metal joining process wherein coalescence is produced by use of a nonferrous filler metal having a melting point above 427°C (800°F) but lower than that of the base metals being joined. The filler metal is distributed between the closely fitted surfaces of the joint by capillary attraction.

*brazing procedure specification (BPS)*: document that lists the parameters to be used in construction of brazements in accordance with requirements of this Code.

*brittle fracture*: fracture with little or no plastic deformation.

*butt joint*: joint between two members aligned approximately in the same plane.

*butt-lap joint*: combination of butt and lap that has a machined reduction of the wall thickness to allow the insertion of a designated lap distance between the two members, designed for brazing.

*carbon steel*: considered by common custom to be carbon steel when no minimum content is specified or required for aluminum, boron, chromium, cobalt, molybdenum, nickel, niobium, titanium, tungsten, vanadium, zirconium, or any other element added to obtain a desired alloying effect; when the specified minimum for copper does not exceed 0.40%; or when the maximum content specified for any of the following elements does not exceed the following percentages:

- (a) copper: 0.60%
- (b) manganese: 1.65%
- (c) silicon: 0.60%

In all carbon steels, small quantities of certain residual elements unavoidably retained from raw materials are sometimes found but are not specified or required, such as copper, nickel, molybdenum, and chromium. These elements are considered as incidental and are not normally determined or reported.

*cathodic protection (CP)*: technique by which underground metallic pipe is protected against deterioration (rusting and pitting).

*cell*: system consisting of an anode and a cathode immersed in an electrolyte so as to create an electrical circuit. The anode and cathode may be different metals or dissimilar areas on the same metal surface. Also called *electrochemical cell*.

*certification*: written testimony of qualification.

*check valve*: valve designed to permit flow in one direction and to close automatically to prevent flow in the reverse direction.

*class location*: geographic area along the pipeline classified according to the number and proximity of buildings intended for human occupancy and other characteristics that are considered when prescribing design factors for construction, operating pressures, and methods of testing

pipelines and mains located in the area, and applying certain operating and maintenance requirements.

*coating*: liquid, liquefiable, or mastic composition that, after application to a surface, is converted into a solid protective, decorative, or functional adherent film.

*coating system*: complete number and types of coats applied to a substrate in a predetermined order. (When used in a broader sense, surface preparation, pretreatments, dry film thickness, and manner of application are included.)

*cold expanded pipe*: seamless or welded pipe that is formed and then cold expanded while in the pipe mill so that the circumference is permanently increased by at least 0.50%.

*cold spring*: intentional deformation of piping during assembly to produce a desired initial displacement and stress.

*cold spring factor*: ratio of the amount of cold spring provided to the total computed temperature expansion.

*cold springing*: fabrication of piping to an actual length shorter than its nominal length and forcing it into position so that it is stressed in the erected condition, thus compensating partially for the effects produced by the expansion due to an increase in temperature.

*complete weld joint penetration (CWJP)*: includes the depth of bevel and root penetration, plus the required I.D. and O.D. reinforcement.

*concave*: internal condition of the root bead, having an abrupt concave condition with sharp edges.

*concavity*: internal root bead that is properly fused to and completely penetrates the pipe wall but whose center is below the inside surface of the pipe wall. Also called *suck-back*.

*construction organization*: fabricator, contractor, assembler, or installer responsible for all functions involved in the design, fabrication, and erection of the hydrogen piping system.

*consumable insert*: preplaced filler metal that is completely fused into the root of the joint and becomes part of the weld.

*control piping*: all piping, valves, and fittings used to interconnect air, gas, or hydraulically operated control apparatus or instrument transmitters and receivers.

*corrosion*: deterioration of a material, usually a metal, that results from a reaction with its environment.

*crack*: very narrow elongated defect caused by metallurgical or mechanical conditions.

*crevice corrosion*: localized corrosion of a metal surface at, or immediately adjacent to, an area that is shielded from full exposure to the environment because of close proximity of the metal to the surface of another material.

*cryogenic conditions*: low temperature conditions, usually at or below 123 K (−239°F).

*current*: flow of electric charge.

*defect*: imperfection of a type and magnitude exceeding acceptable criteria.

*dents*: indentations of the pipe or distortions of the pipe's circular cross section that change the curvature of a portion of the pipe wall, resulting in a change of the diameters without necessarily reducing its thickness.

*designer*: person or organization in responsible charge of the engineering design.

*design life*: period of time used in design calculations, selected to verify that a replaceable or permanent component is suitable for the anticipated period of service. Design life does not pertain to the life of a pipeline system, because a properly maintained and protected pipeline system can provide liquid transportation service indefinitely.

*design minimum temperature*: lowest component temperature expected in service.

*design pressure*: pressure used in design calculations in [Parts IP](#) and [PL](#) of this Code, determined by the design procedures applicable to the materials and locations involved.

*design temperature*: in a pipeline system, the maximum or minimum temperature at the coincident pressure (minimum or maximum) expected during service. Refer to [para. IP-2.1.4](#) for design temperature for piping systems.

*detect*: to sense or obtain a measurable in-line inspection indication from an anomaly in a pipeline.

*displacement stress range*: corresponding stress differential produced by the difference between strains in the extreme displacement condition and the original (as-installed) condition (or any anticipated condition with a greater differential effect) that remains substantially constant during any one cycle of operation. The displacement stress range is used as the criterion in the design of piping for flexibility.

*dissimilar metals*: different metals that could form an anode/cathode relationship in an electrolyte when connected by an electrically conductive path.

*distribution main*: segment of pipeline in a distribution system installed to convey gas to individual service lines or other mains. Also called *gas main*.

*documented*: condition of being in written form, graphic form, or both.

*double submerged-arc welded pipe*: pipe having a longitudinal butt joint produced by at least two passes, one of which is on the inside of the pipe. Coalescence is produced by heating with an electric arc or arcs between the bare metal electrode or electrodes and the work. The welding is

shielded by a blanket of granular fusible material on the work. Pressure is not used, and filler metal for the inside and outside welds is obtained from the electrode or electrodes.

*ductility*: measure of the capability of a material to be deformed plastically before fracturing.

*elastic distortion*: changes of dimensions of a material upon the application of a stress within the elastic range. Following the release of an elastic stress, the material returns to its original dimensions without any permanent deformation.

*elasticity*: property of a material that allows it to recover its original dimensions following deformation by a stress below its elastic limit.

*electrical interference*: any electrical disturbance on a metallic structure in contact with an electrolyte caused by stray current.

*electric-fusion-welded (EFW) pipe*: pipe having a longitudinal butt joint wherein coalescence is produced in the preformed tube by manual or automatic submerged arc welding (SAW).

*electric-resistance-welded (ERW) pipe*: pipe produced in individual lengths or in continuous lengths from coiled skelp and subsequently cut into individual lengths, having a longitudinal butt joint wherein coalescence is produced by the heat obtained from resistance of the pipe to the flow of electric current in a circuit of which the pipe is a part, and by the application of pressure.

*electrode*:

(a) component of a welding electrical circuit that terminates at the arc, molten conductive slag, or base metal

(b) conductor used to establish contact with an electrolyte and through which current is transferred to or from the electrolyte

*electrolyte*: chemical substance containing ions that migrate in an electric field.

*elevated temperature fluid service*: a fluid service in which the piping metal temperature has a design or sustained operating temperature equal to or greater than the temperature 25°C (50°F) below the temperature identifying the start of time-dependent properties listed under "Notes — Time-Dependent Properties" at the end of Table 1A of the ASME BPVC, Section II, Part D, for the welded base metals. For materials not listed in Section II, Part D, the temperature shall be where the creep rate or stress rupture criteria in [para. IP-2.2.7](#) governs the basic allowable stress value of the welded base metals. When the base metals differ, the lower temperature value shall be used for the joint.

*engineering design*: detailed design governing a piping or pipeline system, developed from process and mechanical requirements, conforming to Code requirements, and

including all necessary specifications, drawings, and supporting documents.

*environment*: surroundings or conditions (physical, chemical, mechanical) in which a material exists.

*erection*: complete installation of a piping system in the locations and on the supports designated by the engineering design, including any field assembly, fabrication, examination, inspection, and testing of the system as required by this Code.

*erosion*: progressive loss of material from a solid surface due to mechanical interaction between that surface and a fluid or solid particles carried with the fluid.

*evaluation*: analysis and determination of a facility's fitness for service under the current operating conditions.

*examination*: direct physical inspection of the piping and pipelines by a person; may also include the use of nondestructive examination techniques (NDE). Examination is required by this Code to verify the integrity and quality of hydrogen piping or pipeline systems.

*examiner*: person who performs quality control or nondestructive examinations.

*fabrication*: preparation of piping components for assembly, including cutting, machining, threading, grooving, forming, bending, welding, brazing, heat treating, examination/inspection, and testing; required for joining of pipe components into subassemblies. Fabrication may be performed in the shop or in the field.

*face of weld*: exposed surface of a weld on the side from which the welding was done.

*failure*: general term used to imply that a part in service has become completely inoperable; is still operable but is incapable of satisfactorily performing its intended function; or has deteriorated seriously, to the point that it has become unreliable or unsafe for continued use.

*fatigue*: phenomenon leading to fracture of a material under repeated or fluctuating stresses having a maximum value less than the tensile strength of the material.

*ferrous material*: material that contains by weight more iron than any single element, having a carbon content generally less than 2% and containing other elements. A limited number of chromium steels may contain more than 2% of carbon, but 2% is the usual dividing line between steel and cast iron.

*filler material*: material to be added in making metallic or nonmetallic joints.

*fillet weld*: weld of approximately triangular cross section joining two surfaces approximately at right angles to each other in a lap joint, tee joint, or corner joint. (See also *size of weld* and *throat of a fillet weld*).

*flammable*: fluid that under ambient or expected operating conditions is a vapor or produces vapors that can be ignited and continue to burn in air. The term thus may apply, depending on service conditions, to fluids defined for other purposes as flammable or combustible.

*flux*: chemical compound applied to the joint surfaces to promote wetting and prevent oxide formation during the brazing operation.

*flux-cored arc welding (FCAW)*: arc welding process that uses an arc between a continuous filler metal electrode and the weld pool. The process is used with shielding gas from a flux contained within the tubular electrode, with or without additional shielding from an externally supplied gas, and without the application of pressure.

*fracture toughness*: resistance of a material to failure from the extension of a crack.

*fusion*: melting together of filler material and base material, or of base material only, that results in coalescence.

*galvanic anode*: metal that provides sacrificial protection to another metal that is more noble when electrically coupled in an electrolyte. This type of anode is the electron source in one type of cathodic protection.

*galvanic corrosion*: accelerated corrosion of a metal because of an electrical contact with a more noble metal or nonmetallic conductor in a corrosive electrolyte.

*gaseous hydrogen (GH<sub>2</sub>) system*: assembly of components to which hydrogen is delivered, stored, and used in the gaseous form. The system may include storage vessels, piping, valves, relief devices, compressors, vacuum system, expansion joints, and gages.

*gas metal-arc welding (GMAW)*: arc-welding process that produces coalescence of metals by heating them with an arc between a continuous filler metal (consumable) electrode and the work. Shielding is obtained entirely from an externally supplied gas or gas mixture.

*gas service line*: piping installed between a main, pipeline, or other source of supply and the meter set assembly.

*gas tungsten-arc welding (GTAW)*: arc-welding process that produces coalescence of metals by heating them with an arc between a single tungsten (nonconsumable) electrode and the work. Shielding is obtained from a gas or gas mixture. Pressure may or may not be used, and filler metal may or may not be used.

*girth weld*: complete circumferential butt weld joining pipe or components.

*gouge*: mechanically induced metal loss, which causes localized elongated grooves or cavities.

*grinding*: reduction in wall thickness by removal of material by hand filing or power disk grinding.

*groove weld*: weld made in the groove between two members to be joined.

*ground temperature*: temperature of the earth at pipeline depth.

*hardness*: ability of a material to resist permanent penetration by a much harder body.

*hardness testing*: can be divided into two groups, macrohardness testing and microhardness testing. Macrohardness testing refers to testing with loads equal to or over 1 kg; microhardness testing refers to 1 000 g or 1 kg. Brinell, Rockwell, and Vickers are examples of macrohardness testers; Micro-Vickers and Knoop are examples of microhardness testers.

*heat affected zone (HAZ)*: that portion of the base material that has not been melted but whose mechanical properties or microstructure have been altered by the heat of welding, brazing, forming, or cutting.

*heat treatment*: heating and cooling a solid metal or alloy in such a way as to obtain desired properties. Heating for the sole purpose of hot working is not considered heat treatment. If a weldment is heated and cooled, then the term *postweld heat treatment* is used.

*high-pressure distribution system*: gas distribution piping system that operates at a pressure higher than the standard service pressure delivered to the customer. In such a system, a service regulator is required on each service line to control the pressure delivered to the customer.

*hoop stress,  $S_H$* : stress in a pipe of wall thickness,  $t$ , acting circumferentially in a plane perpendicular to the longitudinal axis of the pipe, produced by the pressure,  $P$ , of the fluid in a pipe of diameter,  $D$ , and determined by Barlow's formula,  $S_H = PD/2t$ .

*hot taps*: branch piping connections made to operating pipelines, mains, or other facilities while they are in operation. The branch piping is connected to the operating line, and the operating line is tapped while it is under gas pressure.

*hydrogen embrittlement (HE)*: loss of ductility of a metal resulting from absorption of hydrogen.

*hydrogen stress cracking*: cracking that results from the presence of hydrogen in a metal in combination with tensile stress. It occurs most frequently with high-strength alloys.

*hydrostatic test*: pressure test in which the vessel or system is filled completely with water or another liquid. Pressure is then applied to the liquid for the required time, and the outside of the component is visually examined.

*impact testing*: test designed to give information on how a specimen of a known material will respond to a suddenly applied stress, e.g., shock. The test ascertains whether the material is tough or brittle. A notched test piece is normally employed, and the two methods in general use are either Izod or Charpy test. The result is usually

reported as the energy in foot-pounds or kilojoules required to fracture the test piece.

*imperfection*: discontinuity or irregularity that is detected by examination.

*impressed current*: electric current supplied by a device employing a power source that is external to the electrode system. (An example is direct current for cathodic protection.)

*incident*: unintentional release of gas due to the failure of piping or a pipeline.

*inclusion*: nonmetallic phase, such as an oxide, sulfide, or silicate particle, in a metal.

*indication*: finding of a nondestructive testing technique. It may or may not be a defect.

*indication, linear*: in magnetic particle, liquid penetrant, or similar examination, a closed surface area marking or denoting a discontinuity requiring evaluation whose longest dimension is at least 3 times the width of the indication.

*indication, rounded*: in magnetic particle, liquid penetrant, or similar examination, a closed surface area marking or denoting a discontinuity requiring evaluation whose longest dimension is less than 3 times the width of the indication.

*in-line inspection (ILI)*: pipeline inspection technique that uses devices known in the industry as intelligent or smart pigs. These devices run inside the pipe and provide indications of metal loss, deformation, and other defects.

*in-process examination*: includes the verification of documentation for the required quality, personnel qualifications, and material and special process procedures, along with inspection of the fabrication steps required for joining of pipe components.

*inspection*: denotes verifying the performance of examination and tests by an Inspector.

*Inspector*: individual responsible for verifying that all required quality examinations, NDE, inspections, and testing are complete and that all certifications and records have been completed to the extent necessary to satisfy compliance to the requirements of this Code, the engineering design, and the construction organization's quality systems program.

*instrument piping*: all piping, valves, and fittings used to connect instruments to main piping, pipelines, other instruments and apparatus, or measuring equipment.

*integrity*: capability of the pipeline to withstand hoop stress due to operating pressure plus a margin of safety required by this Code.

*integrity assessment*: process that includes inspection of pipeline facilities, evaluating the indications resulting from the inspections, examining the pipe using a variety of techniques, evaluating the results of the

examinations, characterizing the evaluation by defect type and severity, and determining the resulting integrity of the pipeline through analysis.

*intergranular corrosion*: preferential corrosion at or along the grain boundaries of a metal (also known as intercrystalline corrosion).

*internal design pressure*: internal pressure used in calculations or analysis for pressure design of a piping component.

*joint design*: joint geometry together with the required dimensions of the welded joint.

*liquid hydrogen (LH<sub>2</sub>) system*: assembly of components to which hydrogen is delivered, stored, and used in the liquid form. The system may include storage vessels, piping, valves, relief devices, pumps, vacuum system, expansion joints, and gages.

*liquid penetrant examination (PT)*: examination method whereby the metal (ferrous or nonferrous) surface to be examined is coated with a red-dyed penetrating oil. This penetrant is drawn into the surface defects by capillary action. After a sufficient time, the excess penetrant is removed from the surface to be examined, and a white developer is sprayed over the entire surface. The dye, which has penetrated any surface defects, is drawn to the surface by the developer, and the location, geometry, and size of the defects can be determined. This test is considered to be nondestructive because it does not destroy the usefulness of the part being inspected.

*location class*: see *class location*.

*machine welding*: welding with equipment that performs the welding operation under the constant observation and control of a welding operator. The equipment may or may not load and unload the workpieces.

*magnetic particle examination (MT)*: nondestructive test method using magnetic leakage fields and suitable indicating materials to disclose surface and near-surface discontinuity indications.

*manual welding*: welding operation performed and controlled completely by hand.

*maximum allowable hoop stress*: maximum hoop stress permitted by this Code for the design of a piping or pipeline system. It depends on the material used, location of the pipe, operating conditions, and other limitations imposed by the designer in conformance with this Code.

*maximum allowable operating pressure (MAOP)*: maximum pressure at which a gas system may be operated in accordance with the provisions of this Code.

*maximum allowable test pressure*: maximum internal fluid pressure permitted by this Code for a pressure test, based upon the material and location involved.

*maximum operating pressure (MOP)*: sometimes referred to as maximum actual operating pressure, is the highest pressure at which a piping system is operated during a normal operating cycle.

*may*: term that indicates a provision is neither required nor prohibited.

*mechanical damage*: type of metal damage in a pipe or pipe coating caused by the application of an external force. Mechanical damage can include denting, coating removal, metal removal, metal movement, cold working of the underlying metal, and residual stresses, any one of which can be detrimental.

*mechanical joint*: joint for the purpose of mechanical strength or leak resistance, or both, in which the mechanical strength is developed by threaded, grooved, rolled, flared, or flanged pipe ends; or by bolts, pins, toggles, or rings; and the leak resistance is developed by threads and compounds, gaskets, rolled ends, or machined and mated surfaces.

*mechanized welding*: welding with equipment that requires manual adjustment of the equipment controls in response to visual observation of the welding, with the torch, gun, or electrode holder held by a mechanical device.

*metal loss*: any of a number of types of anomalies in pipe in which metal has been removed from the pipe surface, usually due to corrosion or gouging.

*microalloying*: use of small amounts of alloying additions of elements, such as vanadium, niobium, and titanium, which are strong carbide and nitride formers, to achieve improvements in strength, toughness, and weldability through specific thermomechanical processing steps.

*miter*: two or more straight sections of pipe matched and joined on a line bisecting the angle of junction so as to produce a change in direction of more than 3 deg.

*modulus of elasticity*: measure of the stiffness or rigidity of a material. It is actually the ratio of stress to strain in the elastic region of a material. If determined by a tension or compression test, it is also called Young's modulus or the coefficient of elasticity.

*monitoring regulator*: pressure regulator installed in series with another pressure regulator that, in an emergency, automatically assumes control of the pressure downstream of the station, in case that pressure exceeds a set maximum.

*nominal*: numerical identification of dimension, capacity, rating, or other characteristic used as a designation, not as an exact measurement.

*nominal outside diameter*: as-produced or as-specified outside diameter of the pipe. Also called *diameter*.



*nominal pipe size (NPS)*: NPS is followed, when appropriate, by the specific size designation number without an inch symbol.

*nondestructive examination (NDE)*: inspection technique that does not damage the item being examined. This technique includes visual, radiographic, ultrasonic, electromagnetic, and dye penetrant methods.

*nondestructive testing (NDT)*: actual application of a nondestructive testing method or a nondestructive testing technique.

*nonferrous*: metal that does not contain iron as a main ingredient.

*normalizing*: process in which a ferrous metal is heated to a suitable temperature above the transformation range and is subsequently cooled in still air at room temperature.

*normal operating pressure*: predicted pressure (sum of static head pressure, pressure required to overcome friction losses, and any backpressure) at any point in a piping system when the system is operating under a set of predicted steady-state conditions.

*operating company*: individual, partnership, corporation, public agency, owner, agent, or other entity currently responsible for the design, construction, inspection, testing, operation, and maintenance of the piping and/or pipeline facilities and having fiduciary responsibility for such facilities. Also called *operator*.

*outlet header*: length of pipe in which one or more outlets for branch connection have been formed by extrusion, using a die or dies to control the radii of the extrusion.

*overpressure protection*: provided by a device or equipment installed in a piping system that prevents the pressure in the system or part of the system from exceeding a predetermined value.

*owner's Inspector*: See *Inspector*.

*oxidation*: loss of electrons from an atom, compound, or molecule.

*oxygen-arc cutting (OAC)*: oxygen-cutting process that uses an arc between the workpiece and a consumable electrode, through which oxygen is directed to the workpiece. For oxidation-resistant metals, a chemical flux or metal powder is used to facilitate the reaction.

*oxygen cutting (OC)*: group of thermal cutting processes that severs or removes metal by means of the chemical reaction between oxygen and the base metal at elevated temperature. The necessary temperature is maintained by the heat from an arc, an oxyfuel gas flame, or other source.

*parallel encroachment*: portion of the route of a pipeline or main that lies within, runs in a generally parallel direction to, and does not necessarily cross the rights-of-way of a road, street, highway, or railroad.

*peening*: mechanical working of metals using impact blows.

*pig*: device run inside a pipeline to clean or inspect the pipeline or to batch fluids.

*pigging*: use of any independent, self-contained device, tool, or vehicle that moves through the interior of the pipeline for inspecting, dimensioning, or cleaning.

*pig trap (or scraper trap)*: ancillary item of pipeline equipment, such as a launcher or receiver, with associated pipe work and valves, for introducing a pig into a pipeline or removing a pig from a pipeline.

*pipe*: pressure-tight cylinder used to convey a fluid or transmit a fluid pressure, ordinarily designated "pipe" in applicable material specifications. Materials designated "tube" or "tubing" in the specifications are treated as pipe when intended for pressure service. Types of pipe, according to the method of manufacture, include electric-resistance-welded pipe, electric-fusion-welded pipe, double submerged-arc-welded pipe, and seamless pipe.

*pipeline*: all parts of physical facilities through which product moves in transportation, including pipe, valves, fittings, flanges (including bolting and gaskets), regulators, pressure vessels, pulsation dampeners, relief valves, and other appurtenances attached to pipe; compressor units; metering stations; regulator stations; and fabricated assemblies. Included within this definition are gas transmission lines used for transporting gas from production facilities to onshore locations, and gas storage equipment of the closed pipe type, which is fabricated or forged from pipe or fabricated from pipe and fittings.

*pipeline system*: either the operator's entire pipeline infrastructure or large portions of that infrastructure that have definable starting and stopping points.

*pipe-supporting elements*:

(a) *fixtures*: elements that transfer the load from the pipe or structural attachment to the supporting structure or equipment. They include hanging-type fixtures, such as hanger rods, spring hangers, sway braces, counterweights, turnbuckles, struts, chains, guides, and anchors; and bearing-type fixtures, such as saddles, bases, rollers, brackets, and sliding supports.

(b) *structural attachments*: elements that are welded, bolted, or clamped to the pipe, such as clips, lugs, rings, clamps, clevises, straps, and skirts.

*piping*: assembly of piping components used to convey, distribute, mix, separate, discharge, meter, control, or snub fluid flows. Piping also includes pipe-supporting elements but does not include support structures, such as building frames, bents, foundations, or equipment. See also *pipeline*.

*piping components*: for piping or pipelines, the mechanical elements suitable for joining or assembly into pressure-tight, fluid-containing piping systems. Components include pipe, tubing, fittings, flanges, gaskets, bolting,

valves, and such devices as expansion joints, flexible joints, pressure hoses, traps, strainers, in-line portions of instruments, and separators.

*pipng elements*: any material or work required to plan and install a piping or pipeline system. Elements of piping include design specifications, materials, components, supports, fabrication, examination, inspection, and testing.

*pipng installations*: designed piping or pipeline systems to which a selected Code edition applies.

*pitting*: localized corrosion of a metal surface that is confined to a small area and takes the form of cavities called pits.

*plasma arc cutting (PAC)*: arc cutting process that uses a constricted arc and removes molten metal with a high velocity jet of ionized gas issuing from the constricting orifice.

*plasma arc welding (PAW)*: arc-welding process that uses a constricted arc between a nonconsumable electrode and the weld pool (transferred arc), or between the electrode and the constricting nozzle (nontransferred arc). Shielding is obtained from the ionized gas issuing from the torch, which may be supplemented by an auxiliary source of shielding gas. The process is used without the application of pressure.

*plastic deformation*: permanent deformation caused by stressing beyond the elastic limit.

*pneumatic test*: a test performed on a pressure vessel or system in which air or gas is introduced and pressurized to a designated level.

*postweld heat treatment (PWHT)*: heat treatment subsequent to welding.

*preheating*: application of heat to the base material immediately before or during a forming, welding, or cutting process.

*pressure limiting station*: consists of equipment that under abnormal conditions will act to reduce, restrict, or shut off the supply of gas flowing into a system to prevent the gas pressure from exceeding a predetermined value. While normal pressure conditions prevail, the pressure limiting station may exercise some degree of control of the flow of the gas or may remain in the wide open position. Included in the station are piping and auxiliary devices, such as valves, control instruments, control lines, the enclosure, and ventilating equipment.

*pressure regulating station*: consists of equipment installed for automatically reducing and regulating the pressure in the downstream pipeline or main to which it is connected. Included are piping and auxiliary devices such as valves, control instruments, control lines, the enclosure, and ventilation equipment.

*pressure relief station*: consists of equipment installed to vent gas from a system being protected to prevent the gas pressure from exceeding a predetermined limit. The gas may be vented into the atmosphere or into a lower pressure system capable of safely absorbing the gas being discharged. Included in the station are piping and auxiliary devices, such as valves, control instruments, control lines, the enclosure, and ventilating equipment.

*pressure test*: measure of the strength of a pipeline that is filled with a fluid, sealed, and subjected to pressure. It is used to validate integrity and detect construction defects and defective materials.

*procedure qualification record (PQR)*: document listing all pertinent data, including the essential variables employed and the test results, used in qualifying the welding procedure specification or brazing procedure specification.

*protective coating*: coating applied to a surface to protect the substrate from corrosion.

*purging gas*: gas, such as argon, helium, nitrogen, or reactive gas, that is employed to exclude oxygen from the root side (opposite from the welding side) of weld joints. Also called *backing gas*.

*qualification*: demonstrated skill and knowledge, along with documented training and experience, required for personnel to properly perform the duties of a specific job.

*quality control examination*: examination that applies to quality control functions performed by the manufacturer (for components only), fabricator, or erector. Reference in this Code to an examiner is to a person who performs quality control examinations under the construction organization's quality systems program.

*radiographic examination (RT)*: use of X-rays or nuclear radiation, or both, to detect discontinuities in material and to present their images on a recording medium. Also called *radiographic inspection*.

*reinforcement, branch*: required to sustain the pressure as determined by design, and includes weld reinforcement and component thickness and reinforcing rings or saddles.

*reinforcement, weld joint*: weld material in excess of the specified fillet weld size, depth of groove, and O.D. and I.D. surfaces.

*residual stress*: stress present in an object in the absence of any external loading. It results from the fabricating process, heat treatment, or mechanical working of material.

*resistivity*: measure of the ability of an electrolyte (e.g., soil) to resist the flow of electric charge (e.g., cathodic protection current). Resistivity data are used to design a groundbed for a cathodic protection system.

*right of way (ROW)*: strip of land on which pipelines, railroads, power lines, and other similar facilities are constructed. It secures the right to pass over property

owned by others; ROW agreements only allow the right of ingress and egress for the operations and maintenance of the facility. The width of the ROW can vary and is usually determined based on negotiation with the affected landowner or by legal action.

*risk*: measure of potential loss in terms of both the incident probability (likelihood) of occurrence and the magnitude of the consequences.

*root spacing*: separation between the members to be joined by welding, at the root of the joint (sometimes noted as root opening or open root).

*rupture*: complete failure of any portion of the piping or pipeline caused by the application of a load larger than the piping or pipeline can resist.

*rust*: corrosion product consisting of various iron oxides and hydrated iron oxides. (This term properly applies only to iron and ferrous alloys.)

*safeguarding*: provision of protective measures to minimize the risk of accidental damage to the piping or pipeline or to minimize the harmful consequences of positive failure.

*seal weld*: weld intended primarily to provide joint tightness against leakage in metallic piping.

*seamless pipe*: wrought tubular product made without a welded seam. It is manufactured by hot-working steel and, if necessary, by subsequently cold-finishing the hot-worked tubular product to produce the desired shape, dimensions, and properties.

*seam weld*: longitudinal welds made in pipe manufacturing or in the fabrication process.

*semiautomatic arc welding*: arc welding with equipment that controls only the filler metal feed. The advance of the welding is manually controlled.

*shall*: term used to indicate that a provision is a mandatory Code requirement.

*shielded metal-arc welding (SMAW)*: arc-welding process that produces coalescence of metals by heating them with an arc between a covered metal electrode and the work. Shielding is obtained from decomposition of the electrode covering. Pressure is not used, and filler metal is obtained from the electrode.

*should*: term that indicates that a provision is recommended as good practice but is not a mandatory Code requirement.

*size of weld*:

(a) *fillet weld*: leg lengths (the leg length for equal-leg welds) of the sides, adjoining the members welded, of the largest triangle that can be inscribed within the weld cross

section. For welds between perpendicular members, the definitions in [Figure GR-3.4.7-1](#) apply.

NOTE: When the angle between members exceeds 105 deg, size is of less significance than effective throat (see also *throat of a fillet weld*).

(b) *groove weld*: joint penetration (depth of bevel plus the root penetration when specified). The size of a groove weld and its effective throat are the same.

*slag inclusion*: nonmetallic solid material entrapped in weld metal or between weld metal and base metal.

*specified minimum tensile strength*: minimum tensile strength prescribed by the specification under which a material is purchased from the manufacturer. It is expressed in pounds per square inch.

*specified minimum yield strength (SMYS)*: minimum yield strength prescribed by the specification under which a material is purchased from the manufacturer. It is expressed in pounds per square inch.

*steel*: material that contains by weight more iron than any single element, having a carbon content generally less than 2% and containing other elements. A limited number of chromium steels may contain more than 2% of carbon, but 2% is the usual dividing line between steel and cast iron.

*stop valve*: valve installed for stopping the flow of product in a pipe.

*strain*: increase in length of a material expressed on a unit length basis (e.g., inches per inch or millimeters per millimeter).

*stress*: resultant internal force per unit area that resists change in the size or shape of a body acted on by external forces. In this Code, "stress" is often used synonymously with unit stress.

*stress concentration*: discontinuity in a structure or change in contour that causes a local increase in stress.

*stress corrosion cracking (SCC)*: form of environmental attack of a metal involving an interaction of a local corrosive environment and tensile stresses in the metal, resulting in formation and growth of cracks.

*stress level*: level of tangential or hoop stress, usually expressed as a percentage of specified minimum yield strength.

*stress relieving*: heating a metal to a suitable temperature, holding at that temperature long enough to reduce residual stresses, and then cooling slowly enough to minimize the development of new residual stresses.

*structure-to-soil potential*: potential difference between the surface of a buried or submerged metallic structure and the electrolyte that is measured with reference to an electrode in contact with the electrolyte.

*submerged arc welding (SAW)*: arc-welding process that produces coalescence of metals by heating them with an arc or arcs between a bare metal electrode or electrodes and the work. The arc is shielded by a blanket of granular, fusible material on the work. Pressure is not used, and filler metal is obtained from the electrode and sometimes from a supplemental source (welding rod, flux, or metal granules).

*survey*: measurements, inspections, or observations intended to discover and identify events or conditions that indicate a departure from normal operation of the pipeline.

*temperature*: measure of the thermal energy contained in a material. It is normally expressed in degrees Celsius (°C) or degrees Fahrenheit (°F).

*tensile strength*: highest unit tensile stress (referred to the original cross-section area) a material can sustain before failure.

*tensile stress*: stress that elongates the material.

*throats of a fillet weld*:

*actual throat*: shortest distance from the root of a fillet weld to its face.

*effective throat*: minimum distance, minus any reinforcement (convexity), between the weld root and face of a fillet weld.

*theoretical throat*: perpendicular distance from the hypotenuse of the largest right triangle that can be inscribed in the weld cross section to the root of the joint.

*toe of weld*: junction between the face of a weld and base material.

*transformation range*: temperature range in which a phase change is initiated and completed.

*transmission line*: segment of pipeline installed in a transmission system or between storage fields.

*tube*: see *pipe*.

*tungsten electrode*: nonfiller-metal electrode used in arc welding or cutting, made principally of tungsten.

*ultrasonic*: high-frequency sound.

*ultrasonic examination/inspection (UT)*: examination using high-frequency sound to determine wall thickness and to detect the presence of defects.

*vault*: underground structure that may be entered and that is designed to contain piping and piping components (such as valves or pressure regulators).

*ventilated location*: location where leaking hydrogen cannot reach a concentration of 4% by volume in air for all credible scenarios. See [Nonmandatory Appendix A, para. A-1.2](#).

*visual examination/inspection (VT)*: observation of the portion of components, joints, and other piping elements that are or can be exposed to view before, during, or after

manufacture, fabrication, assembly, erection, examination, or testing. This examination includes verification of Code and engineering design requirements for materials, components, dimensions, joint preparation, alignment, welding, brazing, bolting, threading, or other joining method, supports, assembly, and erection.

*weld*: localized coalescence of metal wherein coalescence is produced by heating to suitable temperatures, with or without the application of pressure, and with or without the use of filler metal.

*welder*: one who is capable of performing a manual or semiautomatic welding operation. (This term is sometimes erroneously used to denote a welding machine.)

*welding operator*: one who operates machine, mechanized, or automatic or semiautomatic welding equipment.

*welding procedure specification (WPS)*: document that lists the parameters to be used in construction of weldments in accordance with requirements of this Code.

*weldment*: assembly whose component parts are joined by welding.

*yield strength*: strength at which a material exhibits a specified limiting permanent set or produces a specified total elongation under load. The specified limiting set or elongation is usually expressed as a percentage of gage length. Its values are specified in the various material specifications acceptable under this Code.

## GR-1.6 ASME B31.12 APPENDICES

### GR-1.6.1 Mandatory Appendices

| Appendix | Title   |
|----------|---|
| I        | Design of Aboveground Hydrogen Gas Pipeline Facilities                                      |
| II       | Reference Standards   |
| III      | Safeguarding  |
| IV       | Nomenclature  |
| VII      | Gas Leakage and Control Criteria  |
| IX       | Allowable Stresses and Quality Factors for Metallic Piping, Pipeline, and Bolting Materials |

### GR-1.6.2 Nonmandatory Appendices

| Appendix | Title  |
|----------|--|
| A        | Precautionary Considerations   |
| B        | Alternative Rules for Evaluating Stress Range  |
| C        | Recommended Practices for Proof Testing of Pipelines in Place  |
| D        | Estimating Strain in Dents   |
| E        | Sample Calculations for Branch Reinforcement in Piping   |
| F        | Welded Branch Connections and Extruded Headers in Pipeline Systems   |
| G        | Guideline for Higher Fracture Toughness Steel in Gaseous Hydrogen Service for Pipelines and Piping Systems |

### **GR-1.6.3 Status of Appendices**

For status of Appendices, see the first page of each Appendix for details that will indicate whether it contains Code requirements, precautionary considerations, guidance, or supplemental information.

### **GR-1.7 NOMENCLATURE**

Dimensional and mathematical symbols used in this Code are listed in [Mandatory Appendix IV](#), with definitions. Uppercase and lowercase English letters are listed alphabetically, followed by Greek letters.

## Chapter GR-2 Materials

### GR-2.1 GENERAL REQUIREMENTS

This Chapter states limitations and required qualifications for materials based on their inherent properties for use in hydrogen systems (see [Nonmandatory Appendix A](#) for guidance). Their use in piping is also subject to requirements and limitations in other parts of this Code. Specific requirements are as follows:

(a) Selection of materials to resist deterioration in service is not addressed completely in this Code. The following should be considered:

(1) temperature and pressure effects of process reactions, properties of reaction or decomposition products, and hazards from instability of contained fluids.

(2) use of cladding, lining, or other protective materials to reduce the effects of corrosion, erosion, and abrasion.

(3) information on material performance in corrosive environments found in publications such as NACE 37519.<sup>1</sup>

(4) hydrogen permeation rates through metals. See Schefer et al.<sup>2</sup> for more information on this topic.

(5) the possibility of exposure of the piping to fire and the melting point, degradation temperature, loss of strength at elevated temperature, and combustibility of the piping material under such exposure.

(6) the susceptibility to brittle failure or failure from thermal shock of the piping material when exposed to fire or to fire-fighting measures, and possible hazards from fragmentation of the material in the event of failure.

(7) the ability of thermal insulation to protect piping against failure under fire exposure (e.g., its stability, fire resistance, and ability to remain in place during a fire).

(8) the possibility of adverse electrolytic effects if the metal is subject to contact with a dissimilar metal.

(9) the compatibility of packing, seals, and O-rings with hydrogen.

(10) the compatibility of materials, such as cements, solvents, solders, and brazing materials, with hydrogen.

(11) the possibility of pipe support failure resulting from exposure to low temperatures (which may embrittle the supports) or high temperatures (which may weaken them).

(b) Hydrogen may affect materials differently than other fluids. The effects may be of a general nature or be temperature and/or pressure specific. Issues the designer should address include but are not limited to

(1) hydrogen embrittlement

(2) property changes at low temperature

(3) property changes at ultra low temperatures

(4) hydrogen permeation rates

(5) electrostatic charge buildup/discharge in electrically nonconductive materials

#### GR-2.1.1 Materials and Specifications

(a) *Listed Materials.* Materials listed in [Table GR-2.1.1-1](#) are suitable for piping meeting the requirements of Part IP. Materials listed in [Table GR-2.1.1-2](#) are suitable for pipelines meeting the requirements of [Part PL](#).

(b) *Unlisted Materials.* Unlisted materials may be used, provided they conform to a published specification covering chemistry, physical and mechanical properties, method and process of manufacture, heat treatment, and quality control, and otherwise meet the requirements of this Code. Allowable stresses shall be determined in accordance with the applicable allowable stress basis of this Code or a more conservative basis.

(c) *Unknown Materials.* Materials of unknown specification shall not be used for pressure-containing piping components.

(d) *Reclaimed Materials.* Reclaimed pipe and other piping components may be used, provided they meet the requirements of (a) or (b) above and otherwise meet the requirements of this Code. Sufficient cleaning and inspection shall be performed to determine minimum wall thickness and freedom from defects.

(e) *Multiple Marking of Materials or Components.* Materials or components marked as meeting the requirements for two or more specifications (or grades, classes, or types) are acceptable, provided the following:

(1) One or more of the multiple markings include a material specification, grade, class, or type of material that is permitted by this Code, and the selected material meets all its requirements.

<sup>1</sup> NACE 37519. Corrosion Data Survey — Metal Section. NACE International — The Corrosion Society.

<sup>2</sup> Schefer, R. W., Houf, W. G., San Marchi, C., Chernicoff, W. P., and Englom, L. (2006). "Characterization of Leaks From Compressed Hydrogen Dispensing Systems and Related Components." *International Journal of Hydrogen Energy* 31(9), 1247–1260. <https://doi.org/10.1016/j.ijhydene.2005.09.003>

**Table GR-2.1.1-1**  
**Material Specification Index for Piping and Pipe Components**

(23)

| Spec. No.   | Title  |
|-------------|--|
| <b>ASTM</b> |  |
| A36         | Carbon Structural Steel [Note (1)]   |
| A53         | Pipe, Steel, Black and Hot-Dipped, Zinc-Coated, Welded and Seamless [Note (2)]   |
| A105        | Carbon Steel Forgings for Piping Applications [Note (2)]   |
| A106        | Seamless Carbon Steel Pipe for High-Temperature Service [Note (2)]   |
| A134        | Pipe, Steel, Electric-Fusion (Arc)-Welded (Sizes NPS 16 and Over) [Note (1)]   |
| A135        | Electric-Resistance-Welded Steel Pipe [Note (2)]   |
| A139        | Electric-Fusion (Arc)-Welded Steel Pipe (NPS 4 and Over) [Note (2)]  |
| A179        | Seamless Cold-Drawn Low-Carbon Steel Heat-Exchanger and Condenser Tubes [Note (2)]   |
| A181        | Carbon Steel Forgings for General-Purpose Piping [Note (2)]  |
| A182        | Forged or Rolled Alloy and Stainless Steel Pipe Flanges, Forged Fittings, and Valves and Parts for High-Temperature Service [Note (2)] |
| A204        | Pressure Vessel Plates, Alloy Steel, Molybdenum [Note (2)]   |
| A213        | Seamless Ferritic and Austenitic Alloy-Steel Boiler, Superheater, and Heat-Exchanger Tubes   |
| A216        | Steel Castings, Carbon, Suitable for Fusion Welding, for High-Temperature Service  |
| A234        | Piping Fittings of Wrought Carbon Steel and Alloy Steel for Moderate and High Temperature Service [Note (2)]                           |
| A240        | Chromium and Chromium-Nickel Stainless Steel Plate, Sheet, and Strip for Pressure Vessels and for General Applications [Note (3)]      |
| A249        | Welded Austenitic Steel Boiler, Superheater, Heat-Exchanger, and Condenser Tubes   |
| A269        | Seamless and Welded Austenitic Stainless Steel Tubing for General Service  |
| A283        | Low and Intermediate Tensile Strength Carbon Steel Plates [Note (1)]   |
| A299        | Pressure Vessel Plates, Carbon Steel, Manganese-Silicon [Note (2)]   |
| A302        | Pressure Vessel Plates, Alloy Steel, Manganese-Molybdenum and Manganese-Molybdenum-Nickel [Note (2)]                                   |
| A312        | Seamless, Welded, and Heavily Cold Worked Austenitic Stainless Steel Pipes [Note (2)]  |
| A333        | Seamless and Welded Steel Pipe for Low-Temperature Service [Notes (2) and (4)]   |
| A334        | Seamless and Welded Carbon and Alloy-Steel Tubes for Low-Temperature Service [Notes (2) and (4)]                                       |
| A335        | Seamless Ferritic Alloy-Steel Pipe for High-Temperature Service [Note (2)]   |
| A350        | Carbon and Low-Alloy Steel Forgings Requiring Notch Toughness Testing for Piping Components [Note (2)]                                 |
| A358        | Electric-Fusion-Welded Austenitic Chromium-Nickel Stainless Steel Pipe for High-Temperature Service and General Applications           |
| A369        | Carbon and Ferritic Alloy Steel Forged and Bored Pipe for High-Temperature Service   |
| A376        | Seamless Austenitic Steel Pipe for High-Temperature Central-Station Service  |
| A381        | Metal-Arc-Welded Steel Pipe for Use With High-Pressure Transmission Systems [Note (2)]   |
| A387        | Pressure Vessel Plates, Alloy Steel, Chromium-Molybdenum [Note (5)]  |
| A403        | Wrought Austenitic Stainless Steel Piping Fittings   |
| A409        | Welded Large Diameter Austenitic Steel Pipe for Corrosive or High-Temperature Service  |
| A420        | Piping Fittings of Wrought Carbon Steel and Alloy Steel for Low-Temperature Service [Note (2)]   |
| A451        | Centrifugally Cast Austenitic Steel Pipe for High-Temperature Service  |
| A479        | Stainless Steel Bars and Shapes for Use in Boilers and Other Pressure Vessels [Note (3)]   |
| A516        | Pressure Vessel Plates, Carbon Steel, for Moderate- and Lower-Temperature Service [Note (5)]   |
| A524        | Seamless Carbon Steel Pipe for Atmospheric and Lower Temperatures [Note (2)]   |
| A537        | Pressure Vessel Plates, Heat-Treated, Carbon-Manganese-Silicon Steel [Note (5)]  |
| A587        | Electric-Resistance-Welded Low-Carbon Steel Pipe for the Chemical Industry [Note (2)]  |
| A671        | Electric-Fusion-Welded Steel Pipe for Atmospheric and Lower Temperatures [Note (2)]  |
| A672        | Electric-Fusion-Welded Steel Pipe for High-Pressure Service at Moderate Temperatures [Note (2)]  |
| A691        | Carbon and Alloy Steel Pipe, Electric-Fusion-Welded for High-Pressure Service at High Temperatures [Note (2)]                          |
| B21         | Naval Brass Rod, Bar, and Shapes   |
| B26         | Aluminum-Alloy Sand Castings   |
| B42         | Seamless Copper Pipe, Standard Sizes   |
| B43         | Seamless Red Brass Pipe, Standard Sizes  |
| B61         | Steam or Valve Bronze Castings [Note (6)]  |
| B62         | Composition Bronze or Ounce Metal Castings [Note (6)]  |



**Table GR-2.1.1-1  
Material Specification Index for Piping and Pipe Components (Cont'd)**

| Spec. No.     | Title   |
|---------------|---|
| ASTM (Cont'd) |   |
| B68           | Seamless Copper Tube, Bright Annealed   |
| B75           | Seamless Copper Tube  |
| B88           | Seamless Copper Water Tube  |
| B96           | Copper-Silicon Alloy Plate, Sheet, Strip, and Rolled Bar for General Purposes and Pressure Vessels                                |
| B98           | Copper-Silicon Alloy Rod, Bar and Shapes  |
| B127          | Nickel-Copper Alloy (UNS N04400) Plate, Sheet, and Strip  |
| B133          | Copper Rod, Bar, and Shapes   |
| B148          | Aluminum-Bronze Sand Castings   |
| B150          | Aluminum Bronze Rod, Bar, and Shapes  |
| B152          | Copper Sheet, Strip, Plate, and Rolled Bar  |
| B165          | Nickel-Copper Alloy (UNS N04400) Seamless Pipe and Tube   |
| B169          | Aluminum Bronze Plate, Sheet, Strip, and Rolled Bar   |
| B171          | Copper-Alloy Condenser Tube Plates  |
| B187          | Copper Bar, Bus Bar, Rod, and Shapes  |
| B209          | Aluminum and Aluminum-Alloy Sheet and Plate   |
| B210          | Aluminum and Aluminum-Alloy Drawn Seamless Tubes  |
| B211          | Aluminum and Aluminum-Alloy Bar, Rod, and Wire  |
| B221          | Aluminum and Aluminum-Alloy Extruded Bars, Rods, Wire, Profiles, and Tubes  |
| B241          | Aluminum and Aluminum-Alloy Seamless Pipe and Seamless Extruded Tube  |
| B247          | Aluminum and Aluminum-Alloy Die Forgings, Hand Forgings, and Rolled Ring Forgings   |
| B280          | Seamless Copper Tube for Air Conditioning and Refrigeration Field Service   |
| B283          | Copper and Copper-Alloy Die Forgings (Hot-Pressed)  |
| B345          | Aluminum and Aluminum-Alloy Seamless Pipe and Seamless Extruded Tube for Gas and Oil Transmission and Distribution Piping Systems |
| B361          | Factory-Made Wrought Aluminum and Aluminum-Alloy Welding Fittings   |
| B466          | Seamless Copper-Nickel Pipe and Tube  |
| B467          | Welded Copper-Nickel Pipe   |
| B491          | Aluminum and Aluminum-Alloy Extruded Round Tubes for General-Purpose Applications   |
| B547          | Aluminum and Aluminum-Alloy Formed and Arc-Welded Round Tube  |
| API           |   |
| 5L            | Line Pipe [Note (2)]  |

## GENERAL NOTES:

- (a) The design pressure shall not exceed 100 MPa (15,000 psi) for all materials unless otherwise noted, provided the material suitability is demonstrated by tests in hydrogen, such as per ASME BPVC, Section VIII, Division 3, Article KD-10.
- (b) See [Mandatory Appendix II](#) for reference dates of specifications.

## NOTES:

- (1) For nonpressure applications only.
- (2) The design pressure shall not exceed 41 MPa (6,000 psi) unless the material suitability is demonstrated by tests in hydrogen, such as per ASME BPVC, Section VIII, Division 3, Article KD-10.
- (3) Austenitic grades only.
- (4) Grades containing Ni additions above 0.50% shall not be used.
- (5) The design pressure shall not exceed 31 MPa (4,500 psi) unless the material suitability is demonstrated by tests in hydrogen, such as per ASME BPVC, Section VIII, Division 3, Article KD-10.
- (6) Brass and bronze castings that are polymer impregnated should not be used.



**Table GR-2.1.1-2**  
**Material Specification Index for Pipelines**

(23)

| Spec. No.   | Title  |
|-------------|--|
| <b>ASTM</b> |  |
| A53         | Pipe, Steel, Black and Hot-Dipped, Zinc-Coated, Welded and Seamless                    |
| A106        | Carbon Steel Pipe for High-Temperature Service   |
| A135        | Electric-Resistance-Welded Steel Pipe  |
| A139        | Electric-Fusion (Arc)-Welded Steel Pipe (NPS 4 and Over)                               |
| A333        | Seamless and Welded Steel Pipe for Low-Temperature Service                             |
| A381        | Metal-Arc-Welded Steel Pipe for Use With High-Pressure Transmission Systems [Note (1)] |
| <b>API</b>  |  |
| 5L          | Line Pipe [Note (1)]   |

## GENERAL NOTES:

- (a) The maximum operating pressure (MOP) shall not exceed 21 MPa (3,000 psi) for all materials unless otherwise noted, provided the material is deemed suitable as demonstrated by tests in hydrogen, such as per ASME BPVC, Section VIII, Division 3, Article KD-10.
- (b) Grades containing Ni additions above 0.50% shall not be used.
- (c) See [Mandatory Appendix II](#) for reference dates of specifications.

NOTE: (1) For ASTM A381 Grade Y65 and API 5L Grades X65 and higher, MOP shall be less than 10 MPa (1,500 psi).

(2) The appropriate allowable stress for the selected material specification, grade, class, or type shall be used. [Mandatory Appendix IX](#) allowable stresses shall be used for a selected listed material.

(3) Each of the multiple markings shall be in accordance with the requirements of the applicable material specification.

(4) All other requirements of this Code are satisfied for the material selected.

(5) For material manufacturers and suppliers, the requirements of ASME BPVC, Section II, Part D, Appendix 7 shall be met for material that is multiple marked.

(b) *Lower Temperature Limits, Listed Materials.* Listed materials may be used at temperatures no colder than the temperature described in this paragraph or as described in ASME B31T, Standard Toughness Requirements for Piping.

(1) A listed material may be used at any temperature not lower than the minimum shown in the tables in [Mandatory Appendix IX](#), provided that the base metal, weld deposits, and HAZ are qualified as required by the applicable entry in Column A of [Table GR-2.1.2-1](#).

(2) For carbon steels with a letter designation in the minimum temperature column of [Mandatory Appendix IX](#), [Table IX-1A](#), the minimum temperature is defined by the applicable curve and Notes in [Figure GR-2.1.2-1](#). If a design minimum metal temperature-thickness combination is on or above the curve, impact testing is not required.

(3) A listed material may be used at a temperature lower than the minimum shown in [Mandatory Appendix IX](#), [Table IX-1A](#) or [Figure GR-2.1.2-1](#) (including Notes), unless prohibited in [Table GR-2.1.2-1](#); [Mandatory Appendix IX](#), [Table IX-1A](#); or elsewhere in the Code, and provided that the base metal, weld deposits, and HAZ are qualified as required by the applicable entry in Column B of [Table GR-2.1.2-1](#). (Tabular values for [Figure GR-2.1.2-1](#) are provided in [Table GR-2.1.2-2](#).)

(4) Where the stress ratio defined in [Figure GR-2.1.2-2](#) is less than one, [Figure GR-2.1.2-2](#) provides a further basis for the use of carbon steels covered by (1) and (2) above, without impact testing.

(-a) For design minimum temperatures of  $-48^{\circ}\text{C}$  ( $-55^{\circ}\text{F}$ ) and above, the minimum design metal temperature without impact testing determined in (b)(2) above, for the given material and thickness, may be reduced by the amount of the temperature reduction provided in [Figure GR-2.1.2-2](#) for the applicable stress ratio. If the

**(23) GR-2.1.2 Temperature Limitations**

The engineering design shall verify that materials that meet other requirements of the Code are suitable for service throughout the operating temperature range. Cautionary and restrictive temperature limits for piping systems are noted in the tables in [Mandatory Appendix IX](#). It is assumed that pipelines will be operated near ambient temperature; therefore, cautions and restrictions due to elevated temperature are not provided in [Mandatory Appendix IX](#). If a pipeline is to be operated significantly above or below ambient temperature, refer to the cautions and restrictions for piping systems.

(a) *Upper Temperature Limits, Listed Materials.* A listed material may be used at a temperature above the maximum for which a stress value or rating is shown, only if

(1) there is no prohibition in [Mandatory Appendix IX](#) or elsewhere in the Code and

(2) the engineering design verifies the serviceability of the material in accordance with (d)

**Table GR-2.1.2-1  
Requirements for Low Temperature Toughness Tests for Metals**

|                               |   | Column A<br>Design Minimum Temperature At or Above<br>Min. Temperature in<br><u>Mandatory Appendix IX, Table IX-1 or Figure GR-2.1.2-1</u>   |   | Column B<br>Design Minimum Temperature<br>Below Min. Temperature in<br><u>Mandatory Appendix IX,<br/>Table IX-1 or Figure GR-2.1.2-1</u>  |
|-------------------------------|---|--|---|---|
|                               | Type of Material  | (a) Base Metal   | (b) Weld Metal and Heat<br>Affected Zone (HAZ)<br>[Note (1)]  |   |
| <b>Listed<br/>Materials</b>   | <b>1</b> Other carbon steels, low and intermediate alloy steels, high alloy ferritic steels, duplex stainless steels  | <b>A-1</b> (a) No additional requirements  | <b>A-1</b> (b) Weld metal deposits shall be impact tested per <a href="#">para. GR-2.1.3</a> if design min. temperature <-29°C (-20°F), except as provided in <a href="#">Notes (2) and (3)</a> , and except as follows: for materials listed for Curves C and D of <a href="#">Figure GR-2.1.2-1</a> , where corresponding welding consumables are qualified by impact testing at the design min. temperature or lower in accordance with the applicable AWS specification, additional testing is not required | <b>B-1</b> Except as provided in <a href="#">Notes (2) and (3)</a> , heat treat base metal per applicable ASTM specification listed in <a href="#">para. GR-2.1.3(b)</a> ; then impact test base metal, weld deposits, and HAZ per <a href="#">para. GR-2.1.3</a> [see <a href="#">Note (1)</a> ]. When materials are used at design min. temperature below the assigned curve as permitted by <a href="#">Figure GR-2.1.2-1, Notes (2) and (3)</a> , weld deposits and HAZ shall be impact tested [see <a href="#">Note (1)</a> ]. |
|                               | <b>2</b> Austenitic stainless steels  | <b>A-2</b> (a) If:<br>(1) carbon content by analysis >0.1%, or<br>(2) material is not in solution heat treated condition, then impact test per <a href="#">para. GR-2.1.3</a> for design min. temperature <-29°C (-20°F) except as provided in <a href="#">Notes (2) and (4)</a> | <b>A-2</b> (b) Weld metal deposits shall be impact tested per <a href="#">para. GR-2.1.3</a> if design min. temperature <-29°C (-20°F), except as provided in <a href="#">para. GR-2.1.2(b)</a> and in <a href="#">Notes (2) and (4)</a>  | <b>B-2</b> Base metal and weld metal deposits shall be impact tested per <a href="#">para. GR-2.1.3</a> . See <a href="#">Notes (1), (2), and (4)</a> .   |
|                               | <b>3</b> Aluminum, copper, nickel, and their alloys; unalloyed titanium   | <b>A-3</b> (a) No additional requirements  | <b>A-3</b> (b) No additional requirements unless filler metal composition is outside the range for base metal composition; then test per column B-3   | <b>B-3</b> Engineering design shall be assured by suitable tests [see <a href="#">Note (5)</a> ] that base metal, weld deposits, and HAZ are suitable at the design min. temperature  |
| <b>Unlisted<br/>Materials</b> | <b>4</b> An unlisted material shall conform to a published specification. Where composition, heat treatment, and product form are comparable to those of a listed material, requirements for the corresponding listed material shall be met. Other unlisted materials shall be qualified as required in the applicable section of column B. |  |   |   |

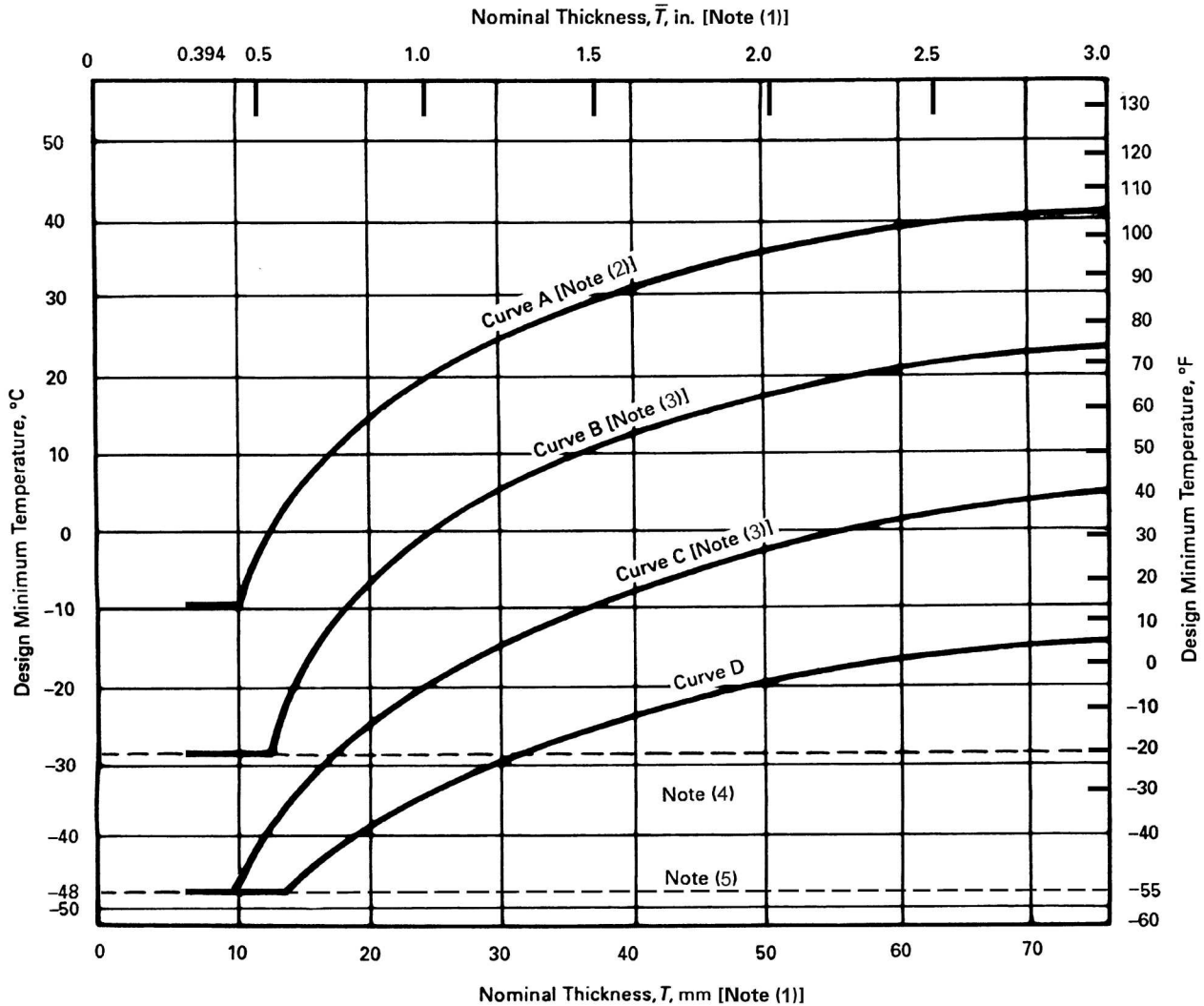
GENERAL NOTE: These toughness test requirements are in addition to tests required by the material specification.

NOTES:

- (1) Impact tests that meet the requirements of [Table GR-2.1.1-1](#), which are performed as part of the weld procedure qualification, will satisfy all requirements of [para. GR-2.1.2\(b\)](#), and need not be repeated for production welds.
- (2) Impact testing is not required if the design minimum temperature is below -29°C (-20°F) but at or above -104°C (-155°F) and the stress ratio defined in [Figure GR-2.1.2-2](#) does not exceed 0.3 times S.
- (3) Impact tests are not required when the maximum obtainable Charpy specimen has a width along the notch of less than 2.5 mm (0.098 in.). Under these conditions, the design minimum temperature shall not be less than the lower of -48°C (-55°F) or the minimum temperature for the material in [Mandatory Appendix IX, Table IX-1A](#).
- (4) Impact tests are not required when the maximum obtainable Charpy specimen has a width along the notch of less than 2.5 mm (0.098 in.).
- (5) Tests may include tensile elongation, sharp-notch tensile strength (to be compared with unnotched tensile strength), and/or other tests conducted at or below design minimum temperature. See also [para. GR-2.1.3\(d\)](#).

(23)

**Figure GR-2.1.2-1**  
**Minimum Temperatures Without Impact Testing for Carbon Steel Materials**



## GENERAL NOTES:

- See [Mandatory Appendix IX, Table IX-1A](#) for designated curve for a listed material.
- See [Table GR-2.1.2-2](#) for tabular values.
- Any carbon steel material may be used to a minimum temperature of  $-29^{\circ}\text{C}$  ( $-20^{\circ}\text{F}$ ).

## NOTES:

- For blind flanges and blanks,  $\bar{T}$  shall be  $\frac{1}{4}$  of the flange thickness.
- X grades of API 5L and ASTM A381 materials may be used in accordance with Curve B if normalized or quenched and tempered.
- The following materials may be used in accordance with Curve D if normalized:
  - ASTM A516 plate, all grades
  - ASTM A671 pipe, Grades CE55, CE60; and all grades made with ASTM A516 plate
  - ASTM A672 pipe, Grades E55, E60; and all grades made with ASTM A516 plate
- A welding procedure for the manufacture of pipe or components shall include impact testing of welds and HAZ for any design minimum temperature below  $-29^{\circ}\text{C}$  ( $-20^{\circ}\text{F}$ ), except as provided in [Table GR-2.1.2-1, A-3\(b\)](#).
- Impact testing in accordance with [para. GR-2.1.3\(b\)](#) is required for any design minimum temperature below  $-48^{\circ}\text{C}$  ( $-55^{\circ}\text{F}$ ), except as permitted by [Note \(2\)](#) in [Table GR-2.1.2-1](#).

**Table GR-2.1.2-2**  
**Tabular Values for Minimum Temperatures Without Impact Testing for Carbon Steel Materials**

(23)

| Nominal<br>Thickness, $\bar{T}$<br>[Note (1)] |        | Design Minimum Temperature |     |                       |     |                       |     |         |     |
|---|--------|----------------------------|-----|-----------------------|-----|-----------------------|-----|---------|-----|
|   |        | Curve A<br>[Note (1)]      |     | Curve B<br>[Note (1)] |     | Curve C<br>[Note (1)] |     | Curve D |     |
| mm  | in.    | °C                         | °F  | °C                    | °F  | °C                    | °F  | °C      | °F  |
| 6.4   | 0.25   | -9.4                       | 15  | -28.9                 | -20 | -48.3                 | -55 | -48.3   | -55 |
| 7.9   | 0.3125 | -9.4                       | 15  | -28.9                 | -20 | -48.3                 | -55 | -48.3   | -55 |
| 9.5   | 0.375  | -9.4                       | 15  | -28.9                 | -20 | -48.3                 | -55 | -48.3   | -55 |
| 10.0  | 0.394  | -9.4                       | 15  | -28.9                 | -20 | -48.3                 | -55 | -48.3   | -55 |
| 11.1  | 0.4375 | -6.7                       | 20  | -28.9                 | -20 | -41.7                 | -43 | -48.3   | -55 |
| 12.7  | 0.5    | -1.1                       | 30  | -28.9                 | -20 | -37.8                 | -36 | -48.3   | -55 |
| 14.3  | 0.5625 | 2.8                        | 37  | -21.7                 | -7  | -35.0                 | -31 | -45.6   | -50 |
| 15.9  | 0.625  | 6.1                        | 43  | -16.7                 | 2   | -32.2                 | -26 | -43.9   | -47 |
| 17.5  | 0.6875 | 8.9                        | 48  | -12.8                 | 9   | -29.4                 | -21 | -41.7   | -43 |
| 19.1  | 0.75   | 11.7                       | 53  | -9.4                  | 15  | -27.2                 | -17 | -40.0   | -40 |
| 20.6  | 0.8125 | 14.4                       | 58  | -6.7                  | 20  | -25.0                 | -13 | -38.3   | -37 |
| 22.2  | 0.875  | 16.7                       | 62  | -3.9                  | 25  | -23.3                 | -10 | -36.7   | -34 |
| 23.8  | 0.9375 | 18.3                       | 65  | -1.7                  | 29  | -21.7                 | -7  | -35.6   | -32 |
| 25.4  | 1.0    | 20.0                       | 68  | 0.6                   | 33  | -19.4                 | -3  | -34.4   | -30 |
| 27.0  | 1.0625 | 22.2                       | 72  | 2.2                   | 36  | -18.3                 | -1  | -33.3   | -28 |
| 28.6  | 1.125  | 23.9                       | 75  | 3.9                   | 39  | -16.7                 | 2   | -32.2   | -26 |
| 30.2  | 1.1875 | 25.0                       | 77  | 5.6                   | 42  | -15.6                 | 4   | -30.6   | -23 |
| 31.8  | 1.25   | 26.7                       | 80  | 6.7                   | 44  | -14.4                 | 6   | -29.4   | -21 |
| 33.3  | 1.3125 | 27.8                       | 82  | 7.8                   | 46  | -13.3                 | 8   | -28.3   | -19 |
| 34.9  | 1.375  | 28.9                       | 84  | 8.9                   | 48  | -12.2                 | 10  | -27.8   | -18 |
| 36.5  | 1.4375 | 30.0                       | 86  | 9.4                   | 49  | -11.1                 | 12  | -26.7   | -16 |
| 38.1  | 1.5    | 31.1                       | 88  | 10.6                  | 51  | -10.0                 | 14  | -25.6   | -14 |
| 39.7  | 1.5625 | 32.2                       | 90  | 11.7                  | 53  | -8.9                  | 16  | -25.0   | -13 |
| 41.3  | 1.625  | 33.3                       | 92  | 12.8                  | 55  | -8.3                  | 17  | -23.9   | -11 |
| 42.9  | 1.6875 | 33.9                       | 93  | 13.9                  | 57  | -7.2                  | 19  | -23.3   | -10 |
| 44.5  | 1.75   | 34.4                       | 94  | 14.4                  | 58  | -6.7                  | 20  | -22.2   | -8  |
| 46.0  | 1.8125 | 35.6                       | 96  | 15.0                  | 59  | -5.6                  | 22  | -21.7   | -7  |
| 47.6  | 1.875  | 36.1                       | 97  | 16.1                  | 61  | -5.0                  | 23  | -21.1   | -6  |
| 49.2  | 1.9375 | 36.7                       | 98  | 16.7                  | 62  | -4.4                  | 24  | -20.6   | -5  |
| 50.8  | 2.0    | 37.2                       | 99  | 17.2                  | 63  | -3.3                  | 26  | -20.0   | -4  |
| 51.6  | 2.0325 | 37.8                       | 100 | 17.8                  | 64  | -2.8                  | 27  | -19.4   | -3  |
| 54.0  | 2.125  | 38.3                       | 101 | 18.3                  | 65  | -2.2                  | 28  | -18.9   | -2  |
| 55.6  | 2.1875 | 38.9                       | 102 | 18.9                  | 66  | -1.7                  | 29  | -18.3   | -1  |
| 57.2  | 2.25   | 38.9                       | 102 | 19.4                  | 67  | -1.1                  | 30  | -17.8   | 0   |
| 58.7  | 2.3125 | 39.4                       | 103 | 20.0                  | 68  | -0.6                  | 31  | -17.2   | 1   |
| 60.3  | 2.375  | 40.0                       | 104 | 20.6                  | 69  | 0.0                   | 32  | -16.7   | 2   |
| 61.9  | 2.4375 | 40.6                       | 105 | 21.1                  | 70  | 0.6                   | 33  | -16.1   | 3   |
| 63.5  | 2.5    | 40.6                       | 105 | 21.7                  | 71  | 1.1                   | 34  | -15.6   | 4   |

**Table GR-2.1.2-2**  
**Tabular Values for Minimum Temperatures Without Impact Testing for Carbon Steel Materials (Cont'd)**

| Nominal Thickness, $\bar{T}$<br>[Note (1)] |        | Design Minimum Temperature |     |                       |    |                       |    |         |    |
|--|--------|----------------------------|-----|-----------------------|----|-----------------------|----|---------|----|
|  |        | Curve A<br>[Note (1)]      |     | Curve B<br>[Note (1)] |    | Curve C<br>[Note (1)] |    | Curve D |    |
| mm   | in.    | °C                         | °F  | °C                    | °F | °C                    | °F | °C      | °F |
| 65.1                                       | 2.5625 | 41.1                       | 106 | 21.7                  | 71 | 1.7                   | 35 | -15.0   | 5  |
| 66.7                                       | 2.625  | 41.7                       | 107 | 22.8                  | 73 | 2.2                   | 36 | -14.4   | 6  |
| 68.3                                       | 2.6875 | 41.7                       | 107 | 22.8                  | 73 | 2.8                   | 37 | -13.9   | 7  |
| 69.9                                       | 2.75   | 42.2                       | 108 | 23.3                  | 74 | 3.3                   | 38 | -13.3   | 8  |
| 71.4                                       | 2.8125 | 42.2                       | 108 | 23.9                  | 75 | 3.9                   | 39 | -13.3   | 8  |
| 73.0                                       | 2.875  | 42.8                       | 109 | 24.4                  | 76 | 4.4                   | 40 | -12.8   | 9  |
| 74.6                                       | 2.9375 | 42.8                       | 109 | 25.0                  | 77 | 4.4                   | 40 | -12.2   | 10 |
| 76.2                                       | 3.0    | 43.3                       | 110 | 25.0                  | 77 | 5.0                   | 41 | -11.7   | 11 |

NOTE: (1) See [Figure GR-2.1.2-1](#) for curves and applicable notes.

resulting temperature is lower than the minimum design metal temperature, impact testing of the material is not required. Where this is applied, the piping system shall also comply with the following requirements:

(-1) The piping shall be subjected to a hydrostatic test at no less than  $1\frac{1}{2}$  times the design pressure.

(-2) Except for piping with a nominal wall thickness of 13 mm ( $\frac{1}{2}$  in.) or less, the piping system shall be safeguarded (see [Mandatory Appendix III](#)) from external loads, such as maintenance loads, impact loads, and thermal shock.

(-b) For design minimum temperatures lower than  $-48^{\circ}\text{C}$  ( $-55^{\circ}\text{F}$ ), impact testing is required for all materials, except as provided by [Note \(5\)](#) of [Table GR-2.1.2-1](#).

(5) The allowable stress or component rating at any temperature below the minimum shown in the tables of [Mandatory Appendix IX](#) or [Figure GR-2.1.2-1](#) shall not exceed the stress value or rating at the minimum temperature in the tables of [Mandatory Appendix IX](#) or the component standard.

(6) Impact testing is not required for the following combinations of weld metals and design minimum temperatures:

(-a) austenitic stainless steel base materials having a carbon content not exceeding 0.10%, welded without filler metal, at design minimum temperatures of  $-101^{\circ}\text{C}$  ( $-150^{\circ}\text{F}$ ) and higher

(-b) austenitic weld metal having a carbon content not exceeding 0.10%, and produced with filler metals conforming to AWS A5.4, AWS A5.9, AWS A5.11, AWS A5.14, or AWS A5.22 at design minimum temperatures of  $-101^{\circ}\text{C}$  ( $-150^{\circ}\text{F}$ ) and higher

(-c) austenitic weld metal having a carbon content not exceeding 0.10%, and produced with filler metals conforming to AWS A5.4, minimum temperatures of  $-48^{\circ}\text{C}$  ( $-55^{\circ}\text{F}$ ) and higher

(c) *Temperature Limits, Unlisted Materials.* An unlisted material, acceptable under [para. GR-2.1.1\(b\)](#), shall be qualified for service at all temperatures within a stated range, from design minimum temperature to design (maximum) temperature, in accordance with [\(d\)](#) below.

(d) *Verification of Serviceability*

(1) When an unlisted material is to be used, or when a listed material is to be used above the highest temperature for which stress values appear in the tables of [Mandatory Appendix IX](#), the designer is responsible for demonstrating the validity of the allowable stresses and other limits used in design and of the approach taken in using the material, including the derivation of stress data and the establishment of temperature limits.

(2) Data for the development of design limits shall be obtained from a sound scientific program carried out in accordance with recognized technology for both the material and the intended service conditions. Factors to be considered include

(-a) applicability and reliability of the data, especially for extremes of the temperature range

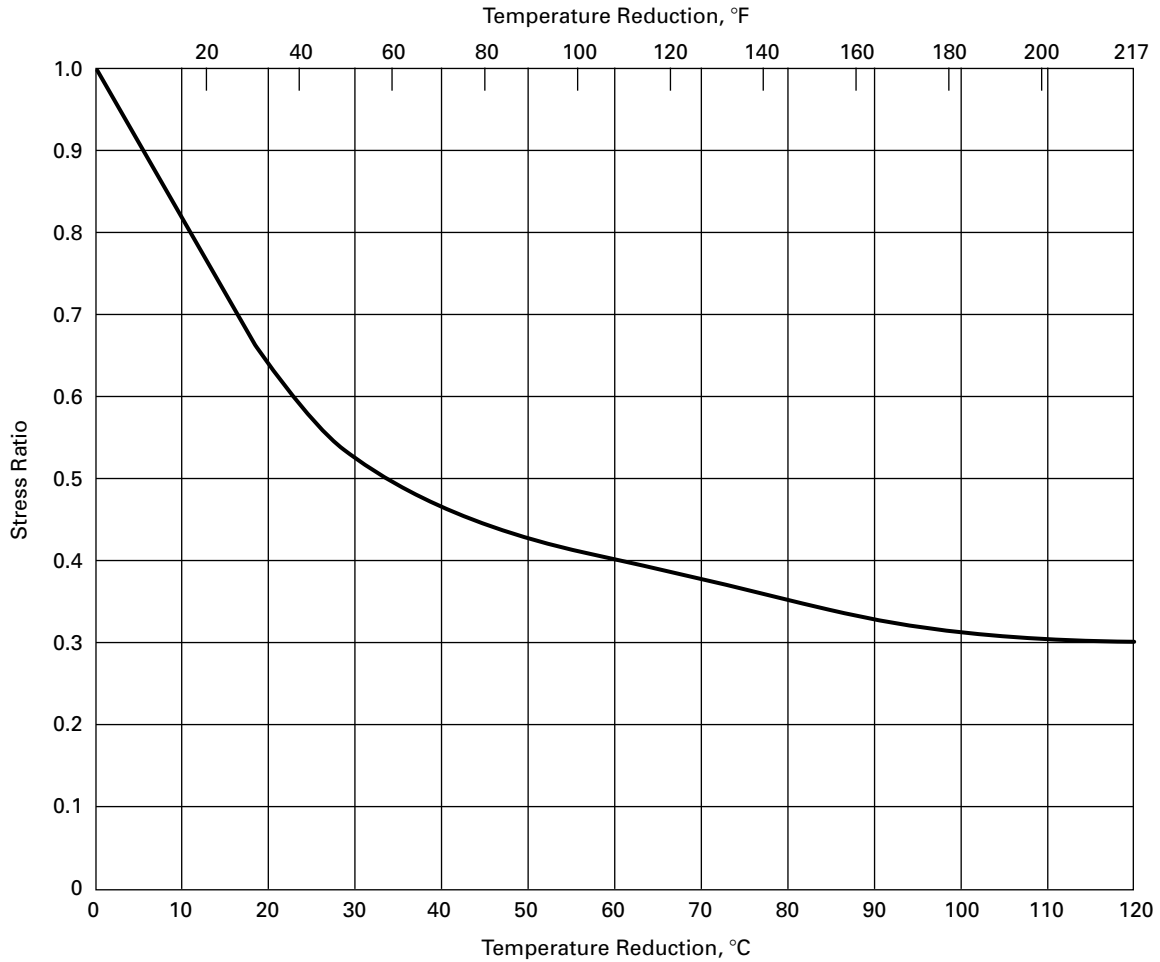
(-b) resistance of the material to deleterious effects of the fluid service and of the environment throughout the temperature range

(-c) determination of allowable stresses in accordance with [para. IP-2.2.6](#)

### GR-2.1.3 Impact Testing Methods and Acceptance Criteria

(a) *General.* When impact testing is required by [Table GR-2.1.2-1](#), provisions elsewhere in this Code, or the engineering design, it shall be done in accordance with [Table GR-2.1.3-1](#) using the testing methods and acceptance criteria described in [\(b\)](#) through [\(e\)](#) below.

**Figure GR-2.1.2-2  
Reduction in Minimum Design Metal Temperature Without Impact Testing**



GENERAL NOTES:

- (a) The stress ratio is defined as the maximum of the following:
  - (1) nominal pressure stress (based on minimum pipe wall thickness less allowances) divided by  $S$  at the design minimum temperature.
  - (2) for piping components with pressure ratings, the pressure for the condition under consideration divided by the pressure rating at the design minimum temperature.
  - (3) combined longitudinal stress due to pressure, dead weight, and displacement strain (stress intensification factors are not included in this calculation) divided by  $S$  at the design minimum temperature. In calculating longitudinal stress, the forces and moments in the piping system shall be calculated using nominal dimensions and the stresses shall be calculated using section properties based on the nominal dimensions less corrosion, erosion, and mechanical allowances.
- (b) Loadings coincident with the metal temperature under consideration shall be used in determining the stress ratio as defined above.

**Table GR-2.1.3-1  
Impact Testing Requirements for Metals**

|   | Test Characteristics                           | Column A<br>Materials Tested by the Manufacturer<br>[Note (1)] or Those in Table GR-2.1.2-1<br>Requiring Impact Tests Only on Welds  | Column B<br>Materials Not Tested by the<br>Manufacturer or Those Tested But<br>Heat Treated During or After<br>Fabrication  |
|---|--|--|---|
| Test on<br>Materials                                  | Number of test                                 | <b>A-1</b> The greater of the number required by (a) the material specification or (b) the applicable specification listed in para. GR-2.1.3(b) [Note (2)]   |   |
|   | Location and orientation of specimens          | <b>2</b> As required by the applicable specification listed in para. GR-2.1.3(b)   |   |
|   | Tests by                                       | <b>A-3</b> The manufacturer  | <b>B-3</b> The fabricator or erector  |
| Tests on<br>Welds in<br>Fabrication<br>or<br>Assembly | Test piece for preparation of impact specimens | <b>4</b> One required for each welding procedure, for each type of filler metal (i.e., AWS E-XXX classification), and for each flux to be used. Test pieces shall be subjected to essentially the same heat treatment (including time at temperature or temperatures and cooling rate) as the erected piping will have received.   |   |
|   | Number of test pieces [Note (3)]               | <b>A-5</b><br>(a) One piece, thickness $T$ , for each range of material thickness from $T/2$ to $T + 6$ mm ( $1/4$ in.)<br>(b) Unless required by the engineering design, pieces need not be made from each lot, nor from material for each job, provided that welds have been tested as required by section 4 above, for the same type and grade of material (or for the same P-Number and Group Number in BPVC, Section IX), of the same thickness range, and that records of the tests are made available | <b>B-5</b><br>(a) One piece from each lot of material in each specification and grade including heat treatment [Note (4)] unless<br>(b) Materials are qualified by the fabricator or erector as specified in B-1 and B-2, in which case the requirements of A-5 apply |
|   | Location and orientation of specimens          | <b>6</b><br>(a) Weld metal: across the weld, with notch in the weld metal; notch axis shall be normal to material surface, with one face of specimen $\leq 1.5$ mm ( $1/16$ in.) from the material surface<br>(b) HAZ: across the weld and long enough to locate notch in the HAZ after etching; notch axis shall be approximately normal to material surface and shall include as much as possible of the HAZ in the fracture   |   |
|   | Test by  | <b>7</b> The fabricator or erector   |   |

## NOTES:

- (1) A certified report of impact tests performed (after being appropriately heat treated as required by Table GR-2.1.2-1, B-3) by the manufacturer shall be obtained as evidence that the material (including any welds used in its manufacture) meets the requirements of this Code and that
  - (a) the tests were conducted on specimens representative of the material delivered to and used by the fabricator or erector, or
  - (b) the tests were conducted on specimens removed from test pieces of the material that received heat treatment separately in the same manner as the material (including heat treatment by the manufacturer) so as to be representative of the finished piping
- (2) If welding is used in manufacture, fabrication, or erection, tests of the HAZ will suffice for the tests of the base material.
- (3) The test piece shall be large enough to permit preparing three specimens from the weld metal and three from the HAZ (if required) per para. GR-2.1.3. If this is not possible, preparation of additional test pieces is required.
- (4) For purposes of this requirement, "lot" means the quantity of material described under the "number of tests" provision of the specification applicable to the product term (i.e., plate, pipe, etc.) listed in para. GR-2.1.3(b).



(b) *Procedure.* Impact testing of each product form of material for any specification (including welds in the components) shall be done using procedures and apparatus in accordance with ASTM A370 and in conformance with impact testing requirements of the specifications in the following table, except that specific requirements of this Code that conflict with requirements of those specifications shall take precedence:

| Product Form | ASTM Spec. No. |
|--------------|----------------|
| Pipe         | A333           |
| Tube         | A334           |
| Fittings     | A420           |
| Forgings     | A350           |
| Castings     | A352           |
| Bolting      | A320           |
| Plate        | A20            |

GENERAL NOTE: Titles of referenced standards not listed in the Specifications Index for [Mandatory Appendix IX](#) are as follows: ASTM A20, General Requirements for Steel Plates for Pressure Vessels, and ASTM A370, Test Methods and Definitions for Mechanical Testing of Steel Products.

(c) *Test Specimens.* Each set of impact test specimens shall consist of three specimen bars. All impact tests shall be made using standard 10 mm (0.394 in.) square cross section Charpy V-notch specimen bars, except when the material shape or thickness does not permit. Charpy impact tests may be performed on specimens of full material thickness, which may be machined to remove surface irregularities. Alternatively, such material may be reduced in thickness to produce the largest possible Charpy subsize specimen (see [Table GR-2.1.3-2](#)). The test specimens shall be in the TL direction. If TL specimens cannot be obtained, then LT specimens may be used.

(d) *Test Temperatures.* For all Charpy impact tests, the test temperature criteria in (1) and (2) below shall be observed. The test specimens, as well as the handling tongs, shall be cooled for a sufficient length of time to reach the test temperature. Pipeline material may be tested according to Annex G in API 5L-2007.

(1) *For Materials of Thickness Equal to or Greater Than 10 mm (0.394 in.).* Where the largest attainable Charpy V-notch specimen has a width along the notch of at least 8 mm (0.315 in.), the Charpy test using such a specimen shall be conducted at a temperature not higher than the design minimum temperature. Where the largest possible test specimen has a width along the notch less than 8 mm (0.315 in.), the test shall be conducted at a temperature lower than the design minimum temperature by the amount shown in [Table GR-2.1.3-2](#) for that specimen width.

(2) *For Materials With Thickness Less Than 10 mm (0.394 in.).* Where the largest attainable Charpy V-notch specimen has a width along the notch of at least 80% of the material thickness, the Charpy test of such

a specimen shall be conducted at a temperature not higher than the design minimum temperature. Where the largest possible test specimen has a width along the notch of less than 80% of the material thickness, the test shall be conducted at a temperature lower than the design minimum temperature by an amount equal to the difference (referring to [Table GR-2.1.3-2](#)) between the temperature reduction corresponding to the actual material thickness and the temperature reduction corresponding to the Charpy specimen width actually tested.

(e) *Acceptance Criteria*

(1) *Minimum Energy Requirements.* Except for bolting materials, the applicable minimum energy requirements for carbon and low alloy steels with specified minimum tensile strengths less than 656 MPa (95 ksi) shall be those shown in [Table GR-2.1.3-3](#).

(2) *Lateral Expansion Requirements.* Other carbon and low alloy steels having specified minimum tensile strengths equal to or greater than 656 MPa (95 ksi), all bolting materials, and all high alloy steels (P-Nos. 6, 7, and 8) shall have a lateral expansion opposite the notch of not less than 0.38 mm (0.015 in.) for all specimen sizes. The lateral expansion is the increase in width of the broken impact specimen over that of the unbroken specimen measured on the compression side, parallel

**Table GR-2.1.3-2  
Charpy Impact Test Temperature Reduction**

| Actual Material Thickness<br>[See <a href="#">Para. GR-2.1.4(c)</a> ]<br>or Charpy Impact Specimen Width<br>Along the Notch [ <a href="#">Note (1)</a> ] |       | Temperature<br>Reduction<br>Below Design<br>Minimum<br>Temperature |    |
|--|-------|--|----|
| mm   | in.   | °C   | °F |
| 10 (full size standard bar)  | 0.394 | 0  | 0  |
| 9  | 0.354 | 0  | 0  |
| 8  | 0.315 | 0  | 0  |
| 7.5 (¾ size bar)   | 0.295 | 2.8  | 5  |
| 7  | 0.276 | 4.4  | 8  |
| 6.67 (⅔ size bar)  | 0.262 | 5.6  | 10 |
| 6  | 0.236 | 8.3  | 15 |
| 5 (½ size bar)   | 0.197 | 11.1   | 20 |
| 4  | 0.157 | 16.7   | 30 |
| 3.33 (⅓ size bar)  | 0.131 | 19.4   | 35 |
| 3  | 0.118 | 22.2   | 40 |
| 2.5 (¼ size bar)   | 0.098 | 27.8   | 50 |

GENERAL NOTE: These temperature reduction criteria do not apply when [Table GR-2.1.3-3](#) specifies lateral expansion for minimum required values.

NOTE: (1) Straight line interpolation for intermediate values is permitted.



**Table GR-2.1.3-3  
Minimum Required Charpy V-Notch Impact Values**

| Specified Minimum Tensile Strength          | Number of Specimens [Note (1)] | Energy [Note (2)]       |        |                                    |        |
|---|--------------------------------|-------------------------|--------|------------------------------------|--------|
|   |                                | Fully Deoxidized Steels |        | Other Than Fully Deoxidized Steels |        |
|   |                                | J                       | ft-lbf | J                                  | ft-lbf |
| <b>(a) Carbon and Low Alloy Steels</b>      |                                |                         |        |                                    |        |
| 448 MPa (65 ksi) and less                   | Average for 3 specimens        | 18                      | 13     | 14                                 | 10     |
|   | Minimum for 1 specimen         | 16                      | 10     | 10                                 | 7      |
| Over 448 to 517 MPa (75 ksi)                | Average for 3 specimens        | 20                      | 15     | 18                                 | 13     |
|   | Minimum for 1 specimen         | 16                      | 12     | 14                                 | 10     |
| Over 517 but not including 656 MPa (95 ksi) | Average for 3 specimens        | 27                      | 20     | ...                                | ...    |
|   | Minimum for 1 specimen         | 20                      | 15     | ...                                | ...    |
| <b>Lateral Expansion, mm (in.)</b>          |                                |                         |        |                                    |        |
| 656 MPa and over [Note (3)]                 | Minimum for 3 specimens        | 0.38 (0.015)            |        |                                    |        |
| <b>(b) Steels in P-Nos. 6, 7, and 8</b>     | Minimum for 3 specimens        | 0.38 (0.015)            |        |                                    |        |

## NOTES:

- (1) See para. GR-2.1.3(e)(4) for permissible retests.
- (2) Energy values in this table are for standard size specimens. For subsize specimens, these values shall be multiplied by the ratio of the actual specimen width to that of a full-size specimen, 10 mm (0.394 in.).
- (3) For bolting of this strength level in nominal sizes M 52 (2 in.) and under, the impact requirements of ASTM A320 may be applied. For bolting over M 52, requirements of this table shall apply.

to the line constituting the bottom of the V-notch (see ASTM A370).

(3) *Weld Impact Test Requirements.* Where two base metals having different required impact energy values are joined by welding, the impact test energy requirements shall conform to the requirements of the base material having a specified minimum tensile strength most closely matching the specified minimum tensile strength of the weld metal.

(4) *Retests*

(-a) *For Absorbed Energy Criteria.* When the average value of the three specimens equals or exceeds the minimum value permitted for a single specimen and the value for more than one specimen is below the required average value, or when the value for one specimen is below the minimum value permitted for a single specimen, a retest of three additional specimens shall be made. The value for each of these retest specimens shall equal or exceed the required average value.

(-b) *For Lateral Expansion Criterion.* If the value of lateral expansion for one specimen in a group of three is below 0.38 mm (0.015 in.) but not below 0.25 mm (0.01 in.), and if the average value for three specimens equals or exceeds 0.38 mm (0.015 in.), a retest of three additional specimens may be made, each of which must equal or exceed the specified minimum value of 0.38 mm (0.015 in.). In the case of heat-treated materials, if the required values are not obtained in the retest or if the values in the initial test are below the minimum allowed for retest, the material may be reheat treated

and retested. After reheat treatment, a set of three specimens shall be made. For acceptance, the lateral expansion of each of the specimens must equal or exceed the specified minimum value of 0.38 mm (0.015 in.).

(-c) *For Erratic Test Results.* When an erratic result is caused by a defective specimen or there is uncertainty in the test procedure, a retest will be allowed.

**GR-2.1.4 Fluid Service Requirements for Materials**

(a) *General.* Requirements in para. GR-2.1.4 apply to pressure-containing parts. They do not apply to materials used for supports, gaskets, packing, or bolting.

(b) *Specific Material Considerations — Metals.* The following are some specific considerations that should be evaluated when selecting certain metals in piping:

(1) *Irons — Cast, Ductile, Malleable, and High Silicon (14.5%).* Due to their lack of ductility and their sensitivity to thermal and mechanical shock, these materials are prohibited.

(2) *Carbon Steel, and Low and Intermediate Alloy Steels*

(-a) the possible conversion of carbides to graphite during long-time exposure to temperatures above 427°C (800°F) of carbon steels, plain nickel steel, carbon-manganese steel, manganese-vanadium steel, and carbon-silicon steel

(-b) the possible conversion of carbides to graphite during long-time exposure to temperatures above 468°C (875°F) of carbon-molybdenum steel, manganese-molybdenum-vanadium steel, and chromium-vanadium steel

(-c) the advantages of silicon-killed carbon steel (0.1% silicon minimum) for temperatures above 482°C (900°F)

(-d) the possibility of damage due to hydrogen exposure at elevated temperatures (see API RP 941)<sup>3</sup>

(-e) the possibility of sulfidation in the presence of hydrogen sulfide at elevated temperatures

### (3) High Alloy (Stainless) Steels

(-a) the possibility of stress corrosion cracking of austenitic stainless steels exposed to media such as chlorides and other halides either internally or externally; the latter can result from improper selection or application of thermal insulation, or from use of marking inks, paints, labels, tapes, adhesives, and other accessory materials containing chlorides or other halides

(-b) the susceptibility to intergranular corrosion of austenitic stainless steels sensitized by exposure to temperatures between 427°C and 871°C (800°F and 1,600°F): an example is stress corrosion cracking of sensitized metal at room temperature by polythionic acid (reaction of oxidizable sulfur compound, water, and air); stabilized or low carbon grades may provide improved resistance (see NACE RP0170)<sup>3</sup>

(-c) the brittleness of ferritic stainless steels at room temperature after service at temperatures above 371°C (700°F)

### (4) Nickel and Nickel Base Alloys

(-a) should be avoided due to HE concerns

(-b) should be avoided in services where the material can be susceptible to grain boundary attack

(-1) nickel and nickel base alloys not containing chromium when exposed to small quantities of sulfur at temperatures above 316°C (600°F)

(-2) nickel base alloys containing chromium at temperatures above 593°C (1,100°F) under reducing conditions

### (5) Aluminum and Aluminum Alloys

(-a) if welding or thermal cutting is performed on aluminum castings, the stress values in [Mandatory Appendix IX](#) and component ratings listed in [Table IP-8.1.1-1](#) are not applicable. It is the engineering design's responsibility to establish such stresses and ratings consistent with the requirements of this Code.

(-b) the compatibility with aluminum of thread compounds used in aluminum threaded joints to prevent seizing and galling.

(-c) the possibility of corrosion from concrete, mortar, lime, plaster, or other alkaline materials used in buildings or structures.

(-d) the susceptibility of Alloy Nos. 5083, 5086, 5154, and 5456 to exfoliation or intergranular attack, and the upper temperature limit of 66°C (150°F) shown in [Mandatory Appendix IX](#) to avoid such deterioration.

### (6) Copper and Copper Alloys

(-a) the possibility of dezincification of brass alloys

(-b) the susceptibility to stress-corrosion cracking of copper-based alloys exposed to fluids such as ammonia or ammonium compounds

(-c) the possibility of unstable acetylide formation when exposed to acetylene

(7) *Lead, Tin, and Lead-Tin Alloys*. Shall not be used in hydrogen service.

(8) *Titanium and Titanium Alloys*. The possibility of deterioration of titanium and its alloys exists.

(9) *Zirconium and Zirconium Alloys*. The possibility of deterioration of zirconium and zirconium alloys exists.

(10) *Tantalum*. Above 299°C (570°F), the possibility of reactivity of tantalum with all gases except the inert gases. Below 299°C (570°F), the possibility of embrittlement of tantalum by nascent (monatomic) hydrogen (but not molecular hydrogen). Nascent hydrogen is produced by galvanic action or as a product of corrosion by certain chemicals.

(11) *Metals With Enhanced Properties*. In a material whose properties have been enhanced by heat treatment, the possible loss of strength during long-continued exposure to temperatures above its tempering temperature.

(12) *Materials With Limited Service*. The desirability of specifying some degree of production impact testing, in addition to the weld procedure qualification tests, when using materials with limited low-temperature service experience below the minimum temperature stated in [Mandatory Appendix IX, Table IX-2](#).

(c) *Cladding and Lining Materials*. Materials with metallic cladding or metallic lining may be used in accordance with the following provisions:

(1) If piping components are made from integrally clad plate conforming to ASTM A263, Corrosion-Resisting Chromium Steel Clad Plate, Sheet, and Strip; ASTM A264, Stainless Chromium-Nickel Steel Clad Plate, Sheet, and Strip; or ASTM A265, Nickel and Nickel-Base Alloy Clad Plate, Sheet, and Strip, pressure design in accordance with rules in [Chapter IP-3](#) may be based upon the total thickness of base metal and cladding after any allowance for corrosion has been deducted, provided that both the base and cladding metals are acceptable for Code use under [para. GR-2.1.1](#), and provided that the clad plate has been shear tested and meets all shear test requirements of the applicable ASTM specification. The allowable stress for each material (base and cladding) shall be taken from the tables of [Mandatory Appendix IX](#) or determined in accordance with the rules in [para. IP-2.2.6](#), provided, however, that the allowable stress used for the cladding

<sup>3</sup> Referenced documents are:

API RP 941. Steels for Hydrogen Service at Elevated Temperatures and Pressures in Petroleum Refineries and Petrochemical Plants. American Petroleum Institute.

NACE RP0170. Protection of Austenitic Stainless Steels and Other Austenitic Alloys from Polythionic Acid Stress Corrosion Cracking During Shutdown of Refinery Equipment. NACE International — The Corrosion Society.

portion of the design thickness shall never be greater than the allowable stress used for the base portion.

(2) For all other metallic clad or lined piping components, the base metal shall be an acceptable Code material as defined in [para. GR-2.1.1](#) and the thickness used in pressure design in accordance with [Chapter IP-3](#) shall not include the thickness of the cladding or lining. The allowable stress used shall be that for the base metal at the design temperature. For such components, the cladding or lining may be any material that, in the judgment of the designer, is suitable for the intended service and for the method of manufacture and assembly of the piping component.

(3) Except for components designed in accordance with provisions of [\(1\)](#) above, fluid service requirements for materials stated in this Code shall not restrict their use as cladding or lining in pipe or other components. Fluid service requirements for the outer material (including those for components and joints) shall govern, except that temperature limitations of both inner and outer materials, and of any bond between them, shall be considered.

(4) Fabrication by welding of clad or lined piping components, and the inspection and testing of such components, shall be done in accordance with applicable

provisions of ASME BPVC, Section VIII, Division 1, UCL-30 through UCL-52, or the provisions of [Chapters IP-9](#) and [IP-10](#), whichever are more stringent.

### **GR-2.1.5 Deterioration of Materials in Service**

Selection of material to resist deterioration in service is not completely addressed in this Code. It is the designer's responsibility to select materials suitable for the fluid service. Recommendations based on experience are presented for guidance in [para. GR-2.1](#) and [Nonmandatory Appendix A](#).

### **GR-2.2 JOINING AND AUXILIARY MATERIALS**

When selecting materials such as adhesives, cements, solvents, solders, brazing materials, packing, and O-rings for making or sealing joints, the designer shall consider their suitability for the intended service. (Consideration should also be given to the possible effects of the joining or auxiliary materials on the fluid handled.) In some applications, the fluid being handled contains nonhydrogen constituents, which shall be considered in the material selection.

## Chapter GR-3

# Welding, Brazing, Heat Treating, Forming, and Testing

### (23) GR-3.1 GENERAL

This Chapter provides requirements for welding, brazing, heat treating, forming, and testing for all fabricating and erection of piping components. These requirements are in addition to those of [Parts IP](#) and [PL](#) and the engineering design.

### (23) GR-3.2 WELDING AND BRAZING

The welding and brazing requirements of this Chapter shall apply to the construction of all weldments and braze-ments for qualifications and production. These requirements are in addition to those of [Parts IP](#) and [PL](#).

#### GR-3.2.1 Material Compatibility

See [Chapter GR-2](#) for restrictions due to material compatibility with hydrogen process applications. Requirements for welding and brazing processes, heat treatment, and PWHT shall be based on the selected materials. Dissimilar material connections involving welding or brazing of piping components or attachments to those piping components shall be as required by the engineering design.

#### GR-3.2.2 Responsibility

Each construction organization (fabricator and erector) is responsible per ASME BPVC, Section IX.

### (23) GR-3.2.3 Methods and Processes

The following methods are acceptable for manual welding and brazing, semiautomatic welding, and/or mechanized welding or brazing. See [Chapter GR-1](#), ASME BPVC, Section IX, QG-109, and AWS A3.0 for terms and definitions.

(a) The manual welding includes SMAW, GTAW, and PAW processes.

(b) The semiautomatic welding includes GMAW and FCAW processes.

(c) The mechanized welding methods include programmed or operator-controlled functions.

(1) The processes with filler metal include GTAW, GMAW, FCAW, PAW, and SAW.

(2) The processes without filler metal (autogenous) shall be performed using the GTAW or PAW process.

(d) Manual torch brazing.

(e) Additional welding or brazing processes may be used when permitted by the engineering design or owner.

#### GR-3.2.4 Qualification Testing and Certification Requirements

The procedure specifications and personnel qualifications, testing, and certification shall conform to the requirements of this Chapter and the following:

(a) [Part IP](#) and ASME BPVC, Section IX.

(b) [Part PL](#) and API Standard 1104 or ASME BPVC, Section IX. When welders or welding operators are employed for compressor station piping construction in accordance with [Part PL](#) of this Code, their qualifications shall be based on the destructive mechanical test requirements of ASME BPVC, Section IX or API Standard 1104. Qualifications by NDE, using the RT method, shall be permitted when specified by the engineering design. The RT procedure and technique shall meet the requirements of ASME BPVC, Section V, Article 2 or API Standard 1104. The radiographic acceptance criteria shall meet the requirements of ASME BPVC, Section IX, QW-191.2 or API Standard 1104.

(c) Additional requirements of the engineering design.

#### GR-3.2.5 Method and Process Requirements (23)

(a) All welding methods and processes shall include the following requirements:

(1) Welding material requirements shall be per [para. GR-3.3](#).

(2) The requirements for preheating shall be per [para. GR-3.5](#) and [Table GR-3.5-1](#) and as shown in the engineering design specification and shall apply when welding the test sample or samples.

(3) The requirements for PWHT shall be per [para. GR-3.6.1](#) and [Table GR-3.6.1-1](#) and as shown in the engineering design specification, and shall apply when postweld heat treating the test sample(s).

(4) Hardness testing described in [para. GR-3.10](#) or the engineering design is required when qualifying a WPS/PQR.

(5) When consumable inserts are used, their suitability shall be demonstrated by a qualifying WPS/PQR.

(6) Shielding and backing gas used for welding pipe joints shall be per ASME BPVC, Section II, Part C, specification SFA-5.32.

(7) Backing rings of ferrous or nonferrous material are permitted if allowed by the engineering design and included in the supporting WPS/PQR.

(8) For procedure or performance qualification where the base metal will not withstand the 180 deg guided bend required by ASME BPVC, Section IX, a qualifying welded specimen is required to undergo the same degree of bending as the base metal, within 5 deg.

(b) The additional mandatory (essential) variables for mechanized welding shall include the following:

(1) *Joints*. Weld joint details include backing, root spacing, and alignment.

(2) *Welding With Addition of Filler Metal*. Joint designs for tubing or pipe shall be groove welds (single vee, double vee, or U) or fillet and socket weld joints.

(3) *Welding Without Filler Metal (Autogenous Welding)*. Weld joint geometry shall be square-butt single welded.

(4) *Base Metals*. Material specification, standard, P-No., subgroup number, and actual base metal thickness limits shall be supported by the PQR. For autogenous welding of P-8 materials where two heats with differing sulfur content (>0.005%) are to be joined, consult [Nonmandatory Appendix A, para. A-3.1.2](#), for guidance.

(5) *Filler Metals*. Filler metal shall conform to the requirements of ASME BPVC, Section II, Part C and Section IX, or to a proprietary specification agreed to between the employing contractor and owner. Filler metals may be in the form of welding wire (solid or cored) or consumable inserts.

(-a) diameter range of filler wire or consumable insert configuration

(-b) a change from one AWS classification (per ASME BPVC, Section IX, QW-404.12) of filler metal to another or to a proprietary filler metal

(-c) each designated flux for SAW

(6) *Gas*. Each type or nominal composition of the inert gas used for shielding or plasma shall be documented in the WPS and supported by a PQR. Backing gas shall be used in accordance with ASME BPVC, Section II, Part C, specification SFA-5.32.

(7) *Electrical Characteristics*

(-a) the welding current/polarity, actual amperage and voltage, pulse control, and interpass temperature. The allowable tolerance shall be as specified/qualified per WPS/PQR.

(-b) tungsten electrodes in accordance with ASME BPVC, Section II, Part C, specification SFA-5.12 shall be limited to classification, shape (tip angle and flat size), and type documented on the PQR.

(-c) arc gap control (tip to work distance).

(-d) control arc start (initiation) and stop (termination).

(8) *Technique*

(-a) stringer, weave bead, and oscillation shall be identified.

(-b) orifice, cup, or nozzle size limits.

(-c) oscillation rate, width, and dwell time limits.

(-d) the wire and travel speed limits. The allowable tolerance shall be as specified/qualified per WPS/PQR.

(-e) all welds with filler material shall be multiple passes per side. Autogenous welds without filler material shall be limited to a single pass.

(-f) single electrode per torch (single or dual torch usage).

(-g) mechanized welding functions (programmed or operator controlled) shall be supported by the PQR.

(c) All brazing methods and processes shall include the following requirements:

(1) *Base Metals*. The selected material specification, P-No., and subgroup number for the BPS shall be supported by the PQR with the same material specification, P-No., and subgroup number.

(2) *Brazing Materials*. Limited to a melting temperature above 538°C (1,000°F). Filler wire shall be preplaced or hand (face) fed. The product form of paste (filler) shall not be permitted. (See [para. GR-3.3.4](#) for brazing materials requirements.)

(3) *Brazing Flux and Gas*. Flux shall be limited to the type specified/qualified per BPS/PQR. Fuel gas shall be limited to the type specified/qualified per BPS/PQR.

(4) *Temperature of Brazing Cycle and Flux*. The brazing cycle temperature shall be limited to a maximum of 871°C (1,600°F). The flux selection shall be active at 149°C (300°F) above the maximum filler metal liquidus. The temperatures shall be specified/qualified per BPS/PQR.

(5) *Brazing Joint Detail*. The type of brazing joint detail shall be limited to the type specified/qualified per BPS/PQR, which shall be representative of the production brazement. For details, see [Figure GR-3.8-1](#).

(6) *Precleaning Method*. Shall be limited to the type specified/qualified method per BPS/PQR.

(7) *Internal Purging*. Shall be limited to inert gas. The type shall be specified/qualified per BPS/PQR.

(8) *Postbrazing Cleaning*. Shall be limited to the method specified/qualified per BPS/PQR.

(9) *Postbrazing Heat Treatment*. Shall be performed when specified by the engineering design. Postbrazing heat treatment shall be limited to the type specified/qualified method per BPS/PQR.

(10) Brazements included in a piping system that is subjected to a temperature 538°C (1,000°F) and greater shall require tests in addition to those of ASME BPVC, Section IX. These tests shall be considered a part of the qualification procedure for such design temperatures. Two tension tests on production type joints are required, one at the design temperature and one at 1.05T (where T is

the design temperature in degrees Fahrenheit). Neither of these production-type joints shall fail in the braze metal.

(11) For procedure or performance qualification of test specimens, testing shall be as required per ASME BPVC, Section IX.

### GR-3.2.6 Procedure Qualification by Others

(a) Welding procedures for manual and semiautomatic welding qualified by others may be used subject to the approval of the Inspector, provided that the following conditions are met:

(1) The Inspector shall be satisfied that

(-a) welding procedures and their qualifications meet the requirements of the qualifying Code

(-b) construction organizations participating in the interchange have a Quality Control System/Quality Assurance Program that describes the operational control of WPS development and procedure qualifications

(-c) the construction organization has adopted the WPS

(-d) the construction organization has not made any change in the welding procedure

(2) The welding processes are limited to SMAW, GMAW, FCAW, GTAW, or a combination thereof.

(3) By certifying signature, the construction organization accepts responsibility for both the WPS and the PQR.

(4) The construction organization has at least one currently employed welder or welding operator who, while in its employ, has satisfactorily passed a performance qualification test using the designated WPS.

(b) Mechanized welding procedure qualifications by others are not allowed.

(c) Brazing procedures for the manual method qualified by others may be used subject to the approval of the Inspector, provided that the following conditions are met:

(1) The Inspector shall be satisfied that

(-a) brazing procedures and their qualifications meet the requirements of the qualifying Code

(-b) construction organizations participating in the interchange have a Quality Control System/Quality Assurance Program that describes the operational control of BPS development and procedure qualifications

(-c) the construction organization has adopted the BPS

(-d) the construction organization has not made any change in the brazing procedure

(2) The brazing process(es) and method are limited to silver filler metal/manual torch brazing.

(3) By certifying signature, the construction organization accepts responsibility for both the BPS and the PQR.

(4) The construction organization has at least one currently employed brazer who, while in its employ, has satisfactorily passed a performance qualification test using the designated BPS.

### GR-3.2.7 Performance Qualification by Others

(a) Welder (manual and semiautomatic) performance qualification made for or by another construction organization may be accepted subject to the approval of the Inspector. The Inspector shall be satisfied that

(1) acceptance is limited to qualification on piping using the same or equivalent WPS, wherein the essential variables are within the limits in the Qualifying Code

(2) the construction organization shall have obtained a copy from the previous construction organization of the performance qualification test record, showing the name of the construction organization, name of the welder, procedure identification, date of successful qualification, and the date that the individual last used the procedure on pressure piping

(3) the welding processes are limited to SMAW, GMAW, FCAW, GTAW, or a combination thereof

(4) by certifying signature, the construction organization accepts responsibility for both the welder qualification and the qualification record (WPQR)

(5) construction organizations participating in the interchange have a Quality Control System/Quality Assurance Program that describes the operational control of welder qualifications, testing, certification, continuity, and record maintenance.

(b) Welder operator qualifications for mechanized or automatic welding by others shall not be allowed.

(c) Brazer (manual) performance qualification made for or by another construction organization may be subject to approval by the Inspector. The Inspector shall be satisfied that

(1) acceptance is limited to qualification on piping using the same or equivalent BPS, wherein the essential variables are within the limits in the qualifying Code

(2) the construction organization shall have obtained a copy from the previous construction organization of the performance qualification test record, showing the name of the construction organization, name of the brazer, procedure identification, date of successful qualification, and the date that the individual last used the procedure on pressure piping

(3) the brazing process(es) and method are limited to silver filler metal/manual torch brazing

(4) by certifying signature, the construction organization accepts responsibility for both the brazer qualification and the qualification record (BPQR)

(5) all construction organizations participating in the interchange have a Quality Control System/Quality Assurance Program that describes the operational control of brazer qualifications, testing, certification, continuity, and record maintenance



### GR-3.2.8 Welder Operator Qualifications

Welder operator qualifications with or without filler material (autogenous welding) shall be limited to the mechanized WPS/PQR and ASME BPVC, Section IX, or API Standard 1104. Three consecutive, acceptable samples shall be required to support welder operator qualification testing.

### GR-3.2.9 Welding and Brazing Records

(a) Each construction organization shall maintain documented records of the following:

- (1) all WPSs/BPSs and PQRs for the duration of their use
  - (2) performance qualifications of the welders, brazers, and welding operators
  - (3) dates and test results of procedure and performance qualifications
  - (4) unique identification of the WPS/BPS/PQR
  - (5) identification number or symbol assigned to each welder and welding operator
  - (6) identification of the production weldment or brazement and the personnel who performed the welding or brazing
- (b) Records shall be made available to the Inspector.

### GR-3.2.10 Requalification Requirements

Welder, brazer, or welding operator requalification tests for each welding or brazing process shall be required if the welder, brazer, or welding operator is not engaged in a given process of welding or brazing for 6 months or more. Requalification for each process shall be performed in accordance with the qualifying code, ASME BPVC, Section IX or API Standard 1104.

## GR-3.3 WELDING AND BRAZING MATERIALS

The requirements for qualifications and construction of weldments and brazements of piping components are provided in [paras. GR-3.3.1 through GR-3.3.4](#).

### GR-3.3.1 Electrodes and Filler Metal

Electrodes and filler metal shall conform to the requirements of ASME BPVC, Section II, Part C. An electrode or filler metal not yet incorporated in ASME BPVC, Section II, Part C may be used with the owner's approval if a procedure qualification test is first successfully made. (See [Nonmandatory Appendix A](#).)

### GR-3.3.2 Weld Backing Material

When backing rings are used, they shall conform to the following:

- (a) *Ferrous Metal Backing Rings*. These shall be of weldable quality. Sulfur content shall not exceed 0.05%.

(b) If two abutting surfaces are to be welded to a third member used as a backing ring, and one or two of the three members are ferritic and the other member or members are austenitic, the satisfactory use of such materials shall be demonstrated by a welding procedure qualified as required by [para. GR-3.2.4](#).

(c) *Nonferrous Backing Rings*. Backing rings of nonferrous material may be used, provided the engineering design approves their use and the welding procedure using them is qualified as required by [para. GR-3.2.4](#). Nonmetallic backing shall be prohibited.

(d) Backing rings shall be solid, formed, or machined, which may be of the flat or tapered design. (Refer to PFI ES-1.)

### GR-3.3.3 Consumable Inserts

Consumable inserts may be used, provided they are of the same nominal composition as the filler metal and will not cause detrimental alloying of the subsequent weld deposit. The welding procedure using consumable inserts shall be qualified as required by [para. GR-3.2.4](#). The consumable insert shall be used for welding the root pass of butt welded pipe components requiring CWJP using the GTAW or PAW processes.

### GR-3.3.4 Brazing Materials

Brazing materials shall conform to the requirements of ASME BPVC, Section II, Part C, except for brazing material not yet incorporated into Section II, Part C that may be used with the owner's approval if a procedure qualification test is successfully made.

## GR-3.4 CONSTRUCTION OF WELDMENTS

(a) The construction of weldments shall include the following:

- (1) weld joint connections for piping components
- (2) weld metal buildup and weld repairs
- (3) qualification of procedures, welders, and welding operators

(b) Weldments for fabrication and erection shall be made in accordance with a qualified procedure and by qualified welders or welding operators.

(c) Each qualified welder and welding operator shall be assigned a unique identification symbol. Unless otherwise specified in the engineering design, each pressure-containing weld or adjacent area shall be marked with the identification symbol of the welder or welding operator. In lieu of marking the weld, appropriate records shall be filed.

(d) Welding shall not be performed when the temperature of the metal surface within 305 mm (12 in.) of the point of welding in all directions is lower than 16°C (60°F). The work area and surfaces to be welded shall be protected from wind and moisture conditions caused by ice, rain, snow, and running or standing water.

(e) For preheat, see [para. GR-3.5](#) in addition to the specific requirements of [Parts IP](#) and [PL](#).

(f) For postweld heat treat, see [para. GR-3.6](#) in addition to the specific requirements of [Parts IP](#) and [PL](#).

(g) Peening is prohibited for all weldments, including weld metal buildup and repairs.

(h) Valve end connections requiring welding, preheat or PWHT procedures, or both shall preserve the seat tightness of the valve.

(i) Thermal arc, fuel cutting, and fuel heating processes shall be allowed. Oxyacetylene cutting shall be restricted to carbon steel materials.

### GR-3.4.1 Welding Repairs

Welding repairs shall be made using a welding procedure qualified in accordance with [para. GR-3.2.4](#). The WPS and supporting qualifications shall be as permitted by the engineering design. Welding repairs shall be made by welders or welding operators qualified in accordance with [para. GR-3.2.4](#). Preheating and heat treatment shall be as required for the original weldment, base material, or specified WPS. For the original weldment, base material shall be as required by the applicable WPS or PQR.

(a) Repairs by welding shall include repairs to the following:

(1) Defects in base material may be repaired by welding when permitted by the engineering design.

(2) Weld defects shall be repaired. The excavated cavity of the repair area shall be examined by MT or PT in addition to visual examination. Repair of a cavity that differs in contour and dimension from that specified by the WPS is not permitted.

(3) Weld metal buildup shall be allowed when restoring the specified nominal thickness of pipe components or attachments. Weld metal buildup shall not be allowed to increase thickness or to alter alignment. Completed weld metal buildup shall be examined by a volumetric method. All weld buildup shall be as permitted by the engineering design.

(b) Base metal repairs shall be blended uniformly into the surrounding surface. Weld metal buildup used to restore the weld end detail shall be machined uniformly to the contour of the pipe component. Repairs of weldments shall be blended uniformly to the required weld reinforcement.

(c) Acceptance of all weld repairs shall be in accordance with the requirements of [Part IP](#) or [Part PL](#).

### GR-3.4.2 Cleaning of Component Surfaces

Internal and external surfaces to be thermally cut or welded shall be cleaned to remove paint, oil, rust, scale, grease, slag, oxides, and other deleterious material that would be detrimental to the base metal.

### GR-3.4.3 Joint Preparation and Alignment

#### (a) Preparation of Pipe Component Ends

(1) Mechanical cutting and machining methods are acceptable.

(2) Thermal cutting or fuel cutting for end preparation is acceptable if the surface is reasonably smooth, true, and free of slag. The thermal cutting shall be followed by mechanical preparation to achieve the final weld joint end detail. Discoloration (oxidation) remaining from the cutting method shall be removed.

#### (b) Alignment for Welding

(1) Alignment shall be maintained in accordance with the WPS. See [Nonmandatory Appendix A, para. A-3.7](#) for guidance on alignment of welds subject to cyclic service.

(2) Tack welds shall be made with the filler metal specified by the WPS and made by a qualified welder or welding operator. Tack welds shall be removed or fused within the root pass weld. Permanent tack welds shall be examined visually for defects and, if found to be defective, shall be removed. All bridge tacks shall be removed prior to welding the root pass or subsequent deposit.

(c) *Circumferential Autogenous Butt Welds.* Preparation and alignment shall be specified in the WPS supported by the PQR as follows: the ends to be welded shall be prepared by machining or facing to provide an extended land or a square end that meets the requirements of [Figures GR-3.4.3-1](#) and [GR-3.4.3-2](#).

#### (d) Circumferential Groove Butt Welds

(1) End preparation for groove welds shall be specified in the WPS.

(2) Equal component thicknesses may be detailed as shown in [Figure GR-3.4.3-3](#).

(3) Pipe component ends shall be trimmed as shown in [Figures GR-3.4.3-4](#) and [GR-3.4.3-5](#) to correct internal misalignment. Such trimming shall not reduce the finished wall thickness below the required minimum wall thickness,  $t_m$ . To fit backing rings, see [Figures GR-3.4.3-6](#) and [GR-3.4.3-7](#), or for consumable inserts, see [Figure GR-3.4.3-8](#).

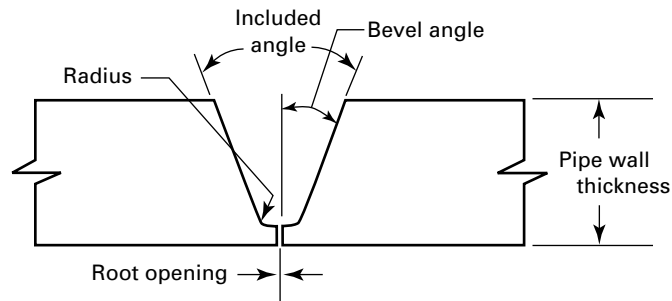
(4) Pipe component ends may be bored to allow for a completely recessed backing ring, provided the remaining net thickness of the finished ends is not less than  $t_m$ .

(5) It is permissible to size pipe ends of the same nominal size to improve alignment if wall thickness requirements are maintained.

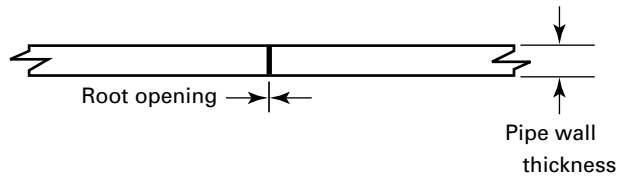
(6) When a butt or miter groove weld joins pipe component ends of unequal wall thickness and one is more than  $1\frac{1}{2}$  times the thickness of the other, end preparation and geometry shall be in accordance with acceptable designs for unequal wall thickness in ASME B16.25 and ASME B16.5.



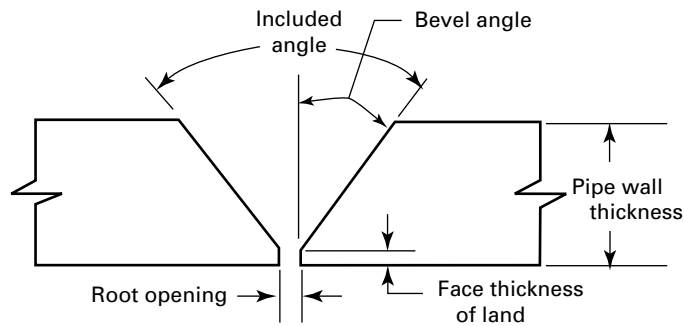
**Figure GR-3.4.3-1**  
**Geometry of Weld Joint Detail Single Vee Groove Butt With Extended Land**



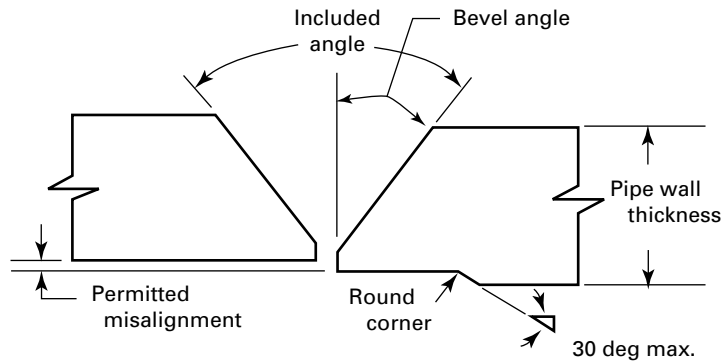
**Figure GR-3.4.3-2**  
**Geometry of Weld Joint Detail Square Butt Weld**



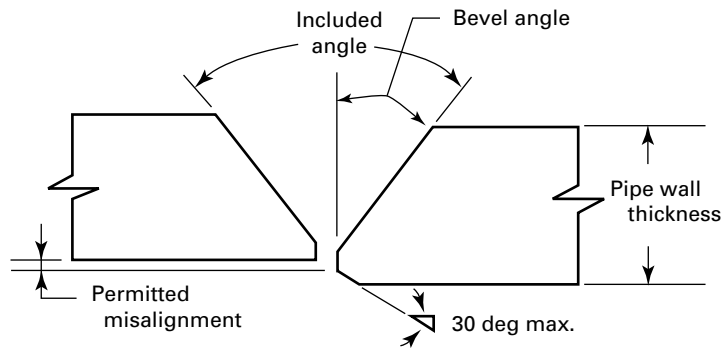
**Figure GR-3.4.3-3**  
**Geometry of Weld Joint Detail Single Vee Groove Butt, Open Root**



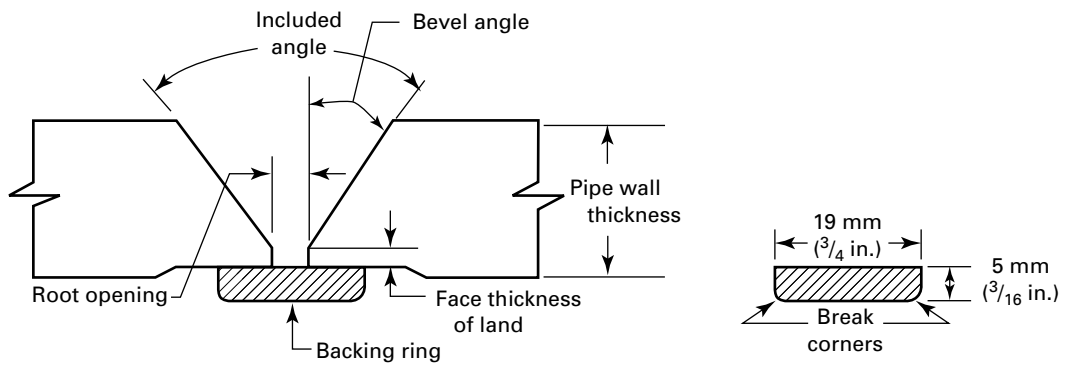
**Figure GR-3.4.3-4**  
**Unequal Pipe Component Thicknesses, Thicker Components Bored for Alignment**



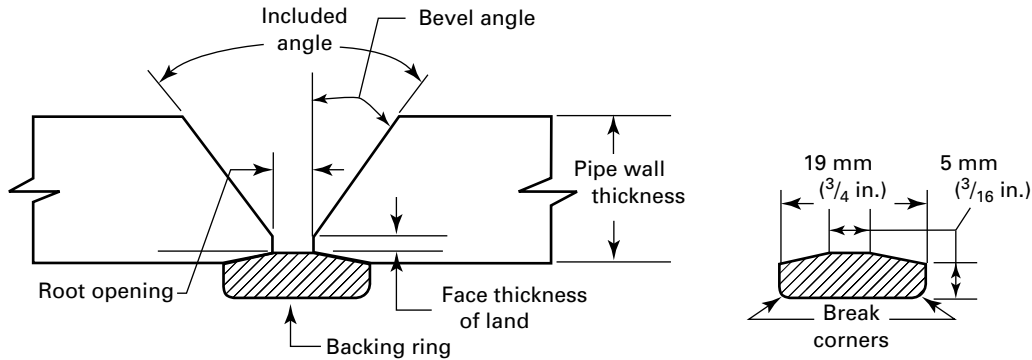
**Figure GR-3.4.3-5**  
**Unequal Pipe Component Thicknesses, Thicker Components Taper-Bored to Align**



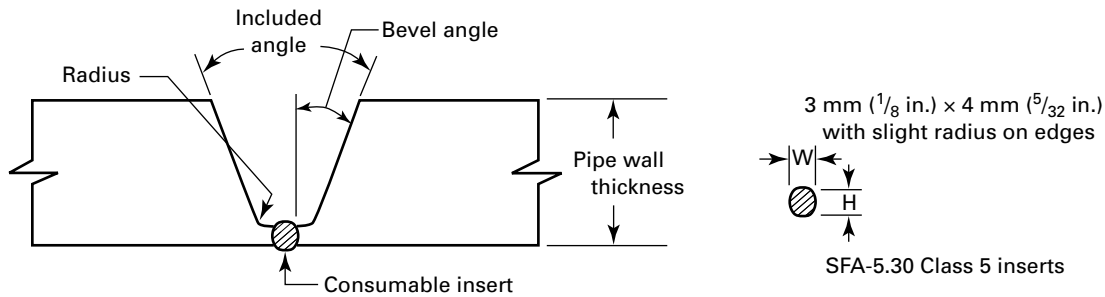
**Figure GR-3.4.3-6**  
**Geometry of Weld Joint Detail Single Vee Groove Butt, Continuous Flat Backing Ring**



**Figure GR-3.4.3-7**  
**Geometry of Weld Joint Detail Single Vee Groove Butt, Continuous Tapered Backing Ring**



**Figure GR-3.4.3-8**  
**Geometry of Weld Joint Detail Single Vee Groove Butt, Consumable Insert**



(7) Buttweld fittings manufactured in accordance with ASME B16.9 may be trimmed to produce an angular joint offset in their connections to pipe or other buttweld fittings without being subject to design qualifications in accordance with para. IP-3.8.2, provided the total angular offset produced between the two jointed parts does not exceed 3 deg.

(8) Inside surfaces of pipe component ends to be joined in butt or miter groove welds shall be aligned within the dimensional limits in the WPS and engineering design.

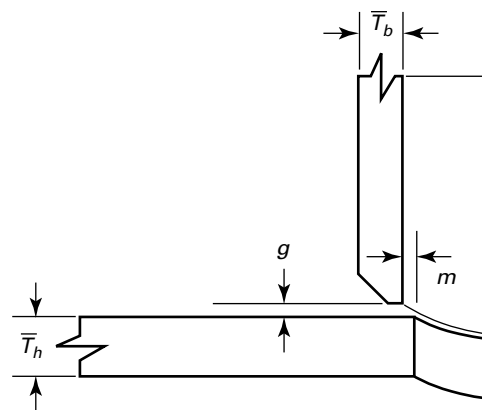
(9) If the external surfaces of the pipe components are not aligned, the weld shall be tapered between them.

(e) *Longitudinal Welds.* End preparation and alignment of longitudinal groove welds shall conform to the requirements of (d).

(f) *Branch Connection Welds*

(1) Branch connections that abut the outside surface of the run pipe shall be contoured for groove welds that meet the WPS requirements (see Figure GR-3.4.3-9).

**Figure GR-3.4.3-9**  
**Preparation and Alignment of Pipe Branch to Pipe Header Connection**



- Legend:
- $g$  = root gap per welding specification
  - $m$  = the lessor of 3.2 mm ( $1/8$  in.) or  $0.5 \bar{T}_b$
  - $\bar{T}_b$  = nominal thickness of branch
  - $\bar{T}_h$  = nominal thickness of header

(2) Run openings for branch connections shall not deviate from the required contour more than  $m$ . In no case shall deviations of the shape of the opening cause the root spacing tolerance limits of the WPS to be exceeded. The addition of weld metal to correct the shape of the opening or the root spacing tolerance requires a qualified weld repair procedure, approved by the engineering design. See [para. GR-3.4.4.1](#).

(3) Connections that require the pipe branch to penetrate into the pipe header shall not be permitted unless approved by the engineering design.

### (23) GR-3.4.4 Welding of Circumferential Joints

(a) Circumferential butt welds of pipe components with the addition of filler metal shall be CWJP welds; shall be made with a single vee, double vee, or other suitable type of groove details; and may include backing rings, consumable inserts, or the open root condition. CWJP for groove welds includes the depth of bevel, root penetration, plus the required I.D. and O.D. reinforcement. The geometry of weld deposit for single vee groove butt/open root is shown in [Figure GR-3.4.4-1](#).

(b) The in-process weld deposit cleaning shall include the removal of all slag, oxides, and other deleterious materials to prevent inclusion of impurities in the weld deposit.

(c) The method and extent of cleaning and removal shall be determined based on the specified base material and weld metal. The method of cleaning or removal shall not be detrimental to the base material or weld deposit.

(d) Root pass welding of circumferential butt welds without the addition of filler material (autogenous) shall be done using GTAW or PAW processes, mechanized or manual, along with the combination of other welding processes with the addition of filler material to complete the weld joint (see [Figure GR-3.4.4-2](#)).

(e) The welding of pipe components (pipe or tube) with a wall thickness maximum of 3.96 mm (0.156 in.) shall be done using GTAW or PAW processes, mechanized or manual, without the addition of filler metal (autogenous welding) (see [Figure GR-3.4.4-3](#)). See [Nonmandatory Appendix A](#) for autogenous weld quality criteria.

### GR-3.4.5 Weld End Transition

(a) *Pipe Component Diameters and Wall Thickness.* When pipe components with different outside diameters or wall thicknesses are welded together, the welding end of the component with the larger outside diameter shall fall within the envelope defined by solid lines in [Figure GR-3.4.5-1](#).

The weld shall form a gradual transition not exceeding a slope of 30 deg from the smaller to the larger diameter component. This condition may be met by the addition of weld buildup, if necessary, beyond what would otherwise be the edge of the weld.

### (b) *Welding of Higher Strength Pipe to Welding Neck Flanges With Unequal Thicknesses*

(1) When the materials joined have equal SMYS, there shall be no restriction on the minimum slope.

(2) Neither pipe component thickness nor their sum,  $t_1 + t_2$ , shall exceed  $0.5t$ .

(3) When the SMYS of the sections to be joined are unequal, the value of  $t_D$  shall at least equal the mating wall thickness times the ratio of SMYS of the pipe to SMYS of the flange.

(4) Welding shall be in accordance with the specified WPS.

### (c) *Requirements for Components Having Unequal Thicknesses, Unequal Strengths, or Both*

(1) When the SMYSs of the sections to be joined are unequal, the deposited weld metal shall have a minimum yield strength at least equal to the SMYS of the section having the higher strength.

(2) Sharp notches or grooves at the edge of the weld where it joins a slanted surface shall be avoided.

(3) For joining unequal thicknesses of equal SMYS, the rules given herein apply, except there is no minimum angle limit to the taper.

(4) The maximum thickness,  $t_D$ , for design purposes shall not be greater than  $1.5t$ .

### (d) *Requirements for Components With Unequal Inside Diameters*

(1) For components that will operate in pipelines (see [Part PL](#)) at hoop stresses of less than 20% of the SMYS, if the nominal wall thicknesses of the adjoining ends do not vary more than 3.2 mm ( $\frac{1}{8}$  in.), no special treatment is necessary, provided the joint design meets the requirement of the WPS.

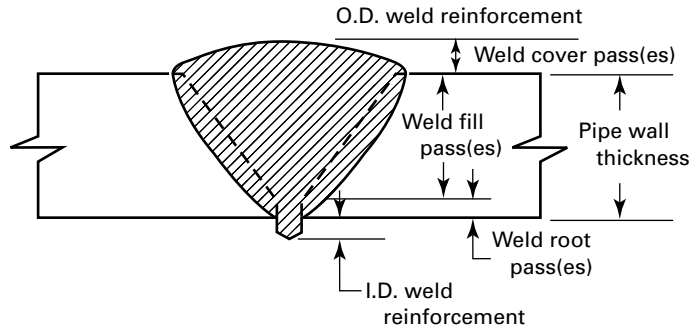
(2) For components that will operate in pipelines (see [Part PL](#)) at hoop stresses of 20% or more than the SMYS, and for all components in piping (see [Part IP](#)), if the nominal wall thickness of the adjoining ends does not vary more than 2.4 mm ( $\frac{3}{32}$  in.), no special treatment is necessary, provided the joint design meets the requirement of the WPS. Where the nominal internal offset is more than 2.4 mm ( $\frac{3}{32}$  in.) and there is no access to the inside of the pipe for welding, the transition shall be made by a taper cut on the inside end of the thicker section. The taper angle shall not be greater than 30 deg.

### (e) *Requirements for Components With Unequal Outside Diameters*

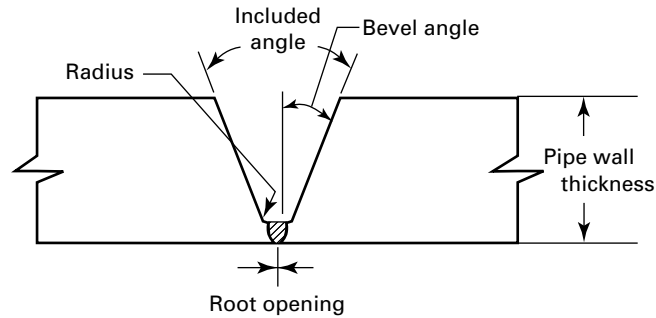
(1) Where the external offset does not exceed one-half of the thinner section, the transition may be made by welding, provided the angle of rise of the weld surface does not exceed 30 deg and both bevel edges are properly fused.

(2) Where there is an external offset exceeding one-half of the thinner section, that portion of the offset over  $\frac{1}{2}t$  shall be tapered as shown in [Figure GR-3.4.5-1](#).

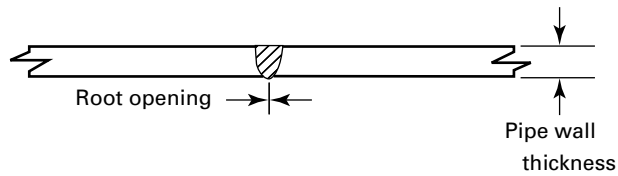
**Figure GR-3.4.4-1**  
**Geometry of Weld Deposit Single Vee Groove Butt, Open Root**



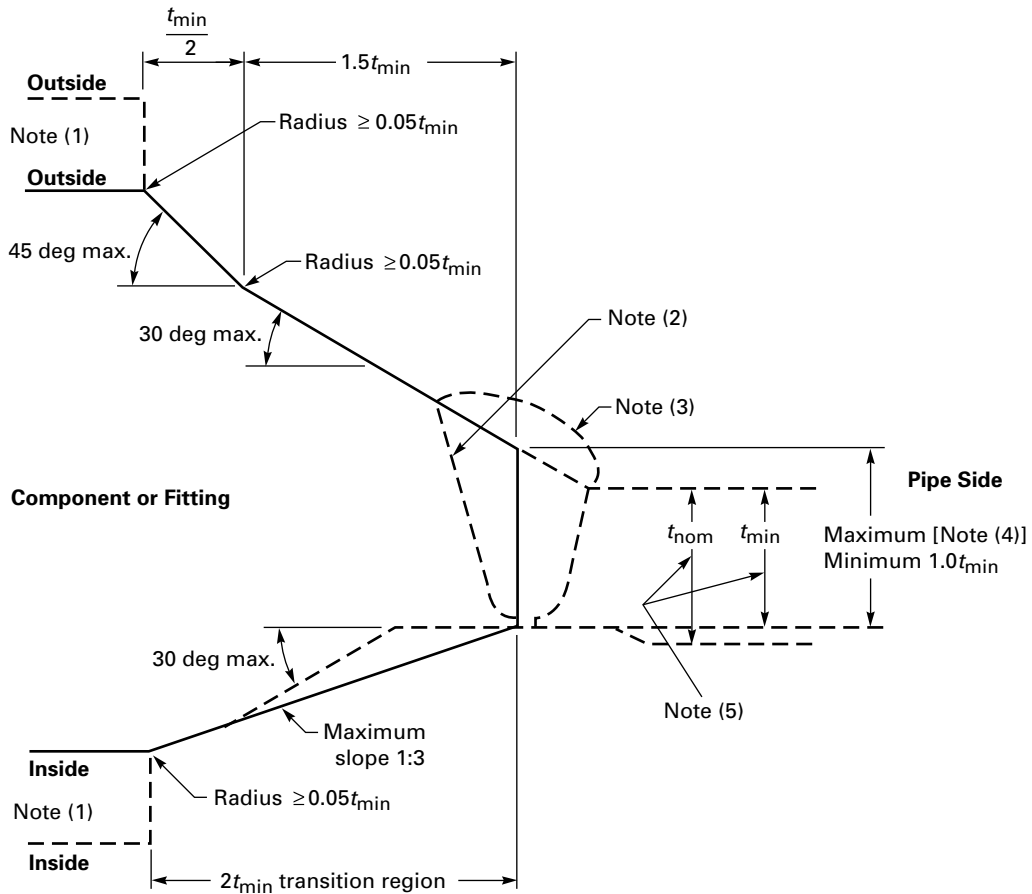
**Figure GR-3.4.4-2**  
**Geometry of Weld Deposit Root Single Vee Groove Butt With Extended Land (Without Filler Metal)**



**Figure GR-3.4.4-3**  
**Geometry of Weld Deposit Square Butt End (Without Filler Metal)**



**Figure GR-3.4.5-1  
Welding End Transition — Maximum Envelope**



NOTES:

- (1) Where transitions using maximum slope do not intersect inside or outside surface, as shown by phantom outlines, maximum slopes shown or alternate radii shall be used.
- (2) Weld bevel shown is for illustration only.
- (3) The weld reinforcement permitted by Table GR-3.4.6-1 may lie outside the maximum envelope.
- (4) The maximum thickness at the end of the component is
  - (a) the greater of  $t_{min} + 4 \text{ mm (0.16 in.)}$  or  $1.15t_{min}$  when ordered on a minimum wall basis
  - (b) the greater of  $t_{min} + 4 \text{ mm (0.16 in.)}$  or  $1.10t_{nom}$  when ordered on a nominal wall basis
- (5) The value of  $t_{min}$  is whichever of the following is applicable:
  - (a) the minimum ordered wall thickness of the pipe
  - (b) 0.875 times the nominal wall thickness of pipe ordered to a pipe schedule wall thickness that has an undertolerance of 12.5%
  - (c) the minimum ordered wall thickness of the cylindrical welding end of a component or fitting (or the thinner of the two) when the joint is between two components

(f) *Component Diameters.* For components with both unequal inside diameters and unequal outside diameters, the joint design shall provide the proper weld transition within the maximum envelope for the outside diameters. For the inside diameters, the joint design shall be machined to allow for the proper transition as shown in Figure GR-3.4.5-1. Particular attention must be paid to proper alignment under these conditions. Weld metal buildup shall not be applied to achieve the internal transition.

**GR-3.4.6 Weld Reinforcement**

Weld reinforcement shall be in accordance with Table GR-3.4.6-1 unless altered by the engineering design. Height of reinforcement or internal protrusion [see Table GR-3.4.6-1, Note (2)] in any plane through the weld shall be within the limits of the applicable height value in the table. Weld metal shall merge smoothly into the component surfaces.

The completed weld reinforcement shall meet the following quality conditions:

(a) When welding pipe component connections, the surface of the weld shall, as a minimum, be flush with the outer surface of pipe components.

(b) As-welded surfaces are permitted; however, the surface of welds shall be sufficiently free from coarse ripples, grooves, overlaps, abrupt ridges, and valleys to meet the following:

(1) The surface condition of the finished weld shall be suitable for the proper interpretation of the inspection and NDE. In those cases where there is a question regarding the evaluation/interpretation, the actual weld surface condition shall be compared for verification.

(2) Undercuts shall not exceed 1.0 mm (1/32 in.) and shall not encroach on the minimum required pipe component thickness.

(3) If the surface of the weld requires grinding to meet the above criteria, care shall be taken to avoid reducing the weld or base material below the minimum required thickness.

(c) Concavity on the root side of a single welded circumferential butt weld is permitted when the resulting thickness of the weld is at least equal to the thickness of the thinner member of the two sections being joined and the contour of the concavity is smooth without sharp edges. The internal condition of the root surface of a circumferential weld, which has been examined by radiography, is acceptable only when there is gradual change in the density, as indicated in the radiograph (see Figure GR-3.4.6-1).

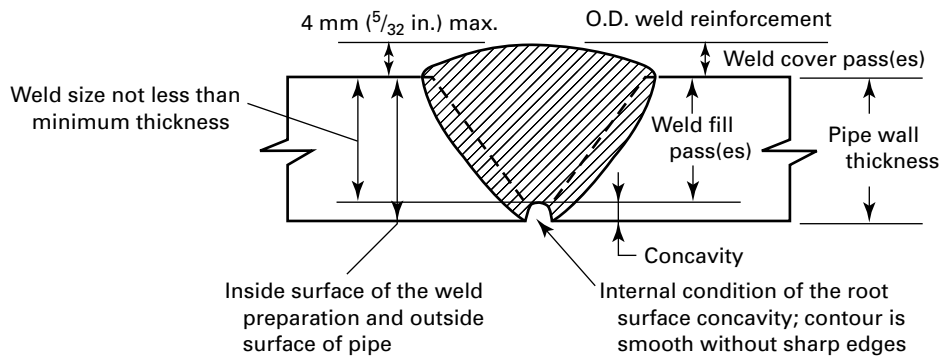
**Table GR-3.4.6-1  
Weld Reinforcement**

| Wall Thickness, $\bar{T}_w$ , mm (in.)<br>[Note (1)] | Height, mm (in.)<br>[Note (2)] |
|--|--------------------------------|
| $\leq 6$ (1/4)                                       | $\leq 1.5$ (1/16)              |
| $> 6$ (1/4) and $\leq 13$ (1/2)                      | $\leq 3$ (1/8)                 |
| $> 13$ (1/2) and $\leq 25$ (1)                       | $\leq 4$ (5/32)                |
| $> 25$ (1)   | $\leq 5$ (3/16)                |

NOTES:

- (1)  $\bar{T}_w$  is the nominal wall thickness of the thinner of two components joined by a butt weld.
- (2) For all butt groove welds (single and double), height is the lesser of the measurements made from the surfaces of the adjacent components; for single groove welds, I.D. reinforcement (internal protrusion) is included in a weld (see Figure GR-3.4.4-1). The minimum weld reinforcement O.D. or I.D. shall be flush to the adjoining surfaces. For fillet welds and added reinforcement to nonbutt groove welds, height is measured from the theoretical throat (see Figure GR-3.4.7-1); internal protrusion does not apply.

**Figure GR-3.4.6-1  
Geometry of Weld Deposit Single Vee Groove Butt, Open Root With Concavity**



### GR-3.4.7 Fillet and Socket Welds

Fillet welds (including socket welds) may vary from convex to concave. The size of a fillet weld is determined as shown in [Figure GR-3.4.7-1](#).

Typical weld details for double welded slip-on flanges are shown in [Figure GR-3.4.7-2](#); minimum welding dimensions for other socket welding components are shown in [Figure GR-3.4.7-3](#) and MSS SP-119.

### GR-3.4.8 Seal Welding of Threaded Joints (See [Figure GR-3.4.7-1](#) for Fillet Weld)

Seal welds shall cover all exposed threads. Seal welding of threaded joints shall not be used for liquid hydrogen service.

### GR-3.4.9 Welded Branch Connections

(a) [Figures GR-3.4.9-1](#) through [GR-3.4.9-4](#) show acceptable details of branch connections, with and without added reinforcement, in which the branch pipe is connected directly to the run pipe. The illustrations are typical and are not intended to exclude acceptable types of construction not shown.

(b) [Figures GR-3.4.9-1](#) through [GR-3.4.9-3](#) show basic types of weld attachments used in the fabrication of branch connections. The location and minimum size of attachment welds shall conform to the requirements herein. Welds shall be calculated in accordance with [para. IP-3.4.2](#) but shall be not less than the sizes shown in [Figure GR-3.4.9-2](#).

(c) The nomenclature and symbols used herein, and in [Figures GR-3.4.9-2](#) and [GR-3.4.9-3](#), are

$r$  = minimum 5 mm ( $\frac{3}{16}$  in.) radius inside corner of branch or header pipe

$\bar{T}_b$  = nominal thickness of branch

$t_c$  = lesser of  $0.7\bar{T}_b$  or 6 mm ( $\frac{1}{4}$  in.)

$\bar{T}_h$  = nominal thickness of header

$T_{mb}$  = minimum thickness of branch

$t_{\min}$  = lesser of  $\bar{T}_b$  or  $\bar{T}_r$

$\bar{T}_r$  = nominal thickness of reinforcing pad or saddle

(d) Branch connections, including pipe and branch connection fittings [see [Chapter GR-1](#) and [paras. IP-3.4](#) and [PL-2.2.4\(c\)](#)], which abut the outside of the run pipe or are inserted in an opening in the run, shall be attached by CWJP groove joints. The welds shall be finished with cover fillet welds having a throat dimension not less than  $t_c$ . See [Figures GR-3.4.9-2](#) and [GR-3.4.9-3](#). Extruded outlets in the run pipe, at the attachment of the branch pipe, should be attached by CWJP groove welds.

(e) A reinforcing pad or saddle shall be attached to the branch pipe by a CWJP groove weld finished with a cover fillet weld having a throat dimension not less than  $t_c$  (see [Figure GR-3.4.9-2](#)).

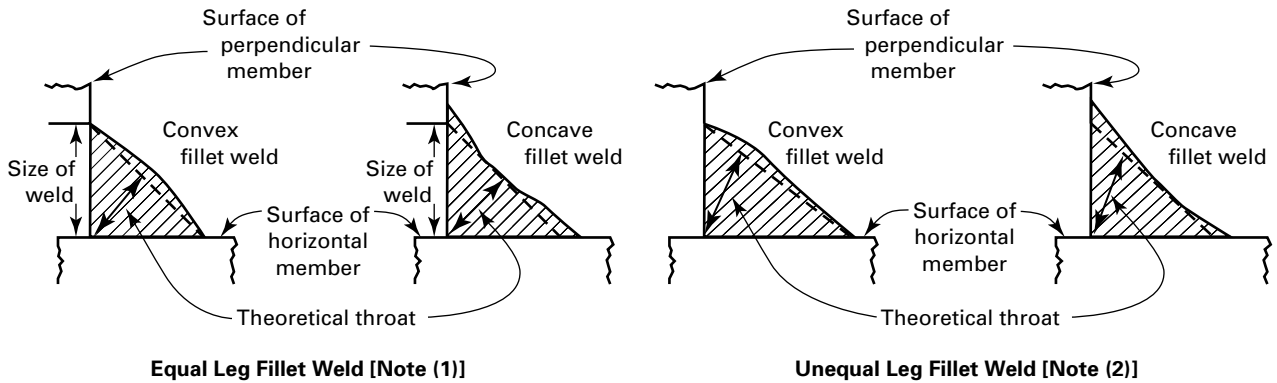
(f) The outer edge of a reinforcing pad or saddle shall be attached to the run pipe by a fillet weld having a throat dimension not less than  $0.5\bar{T}_r$  (see [Figure GR-3.4.9-2](#)).

(g) Reinforcing pads and saddles shall have a good fit with the parts to which they are attached. A vent hole shall be provided at the side (not at the crotch) of any pad or saddle to reveal leakage in the weld between branch and run, and to allow venting during welding and heat treatment. A pad or saddle may be made in more than one piece if joints between pieces have strength equivalent to pad or saddle parent metal and if each piece has a vent hole. Vent holes may be plugged during service to prevent, for example, entry of fluids that may cause corrosion between pipe and reinforcing pad, but the plugging material shall not be capable of sustaining pressure within the crevice.

(h) Examination and any necessary repairs of the completed weld between branch and run shall be made before adding a pad or saddle.



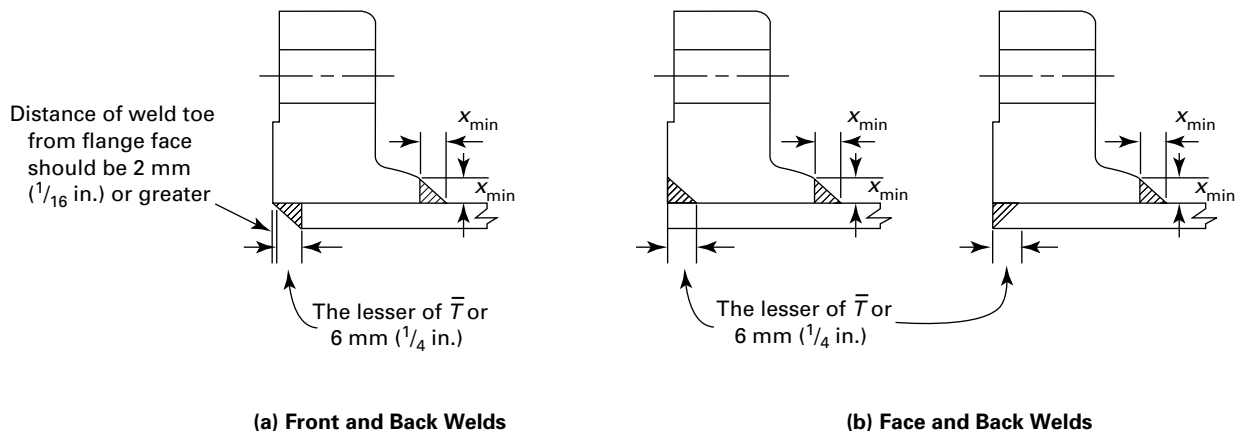
**Figure GR-3.4.7-1  
Fillet Weld Size**



NOTES:

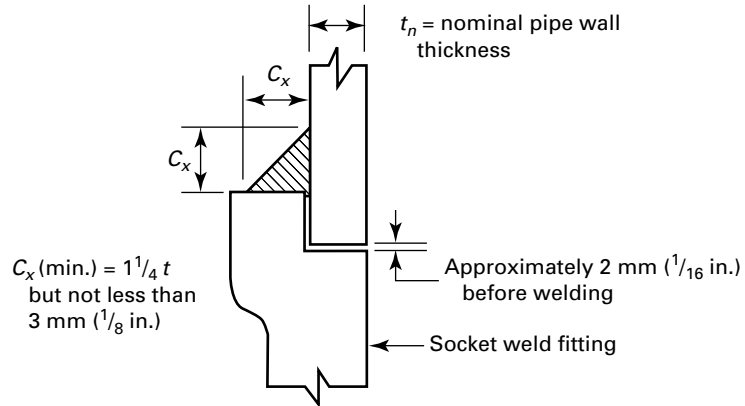
- (1) The size of an equal leg fillet weld is the leg length of the largest inscribed isosceles right triangle (theoretical throat =  $0.707 \times$  size).
- (2) The size of an unequal leg fillet weld is the leg length of the largest right triangle that can be inscribed within the weld cross section [e.g., 13 mm  $\times$  19 mm ( $\frac{1}{2}$  in.  $\times$   $\frac{3}{4}$  in.)].

**Figure GR-3.4.7-2  
Typical Details for Double-Welded Slip-On Flanges**

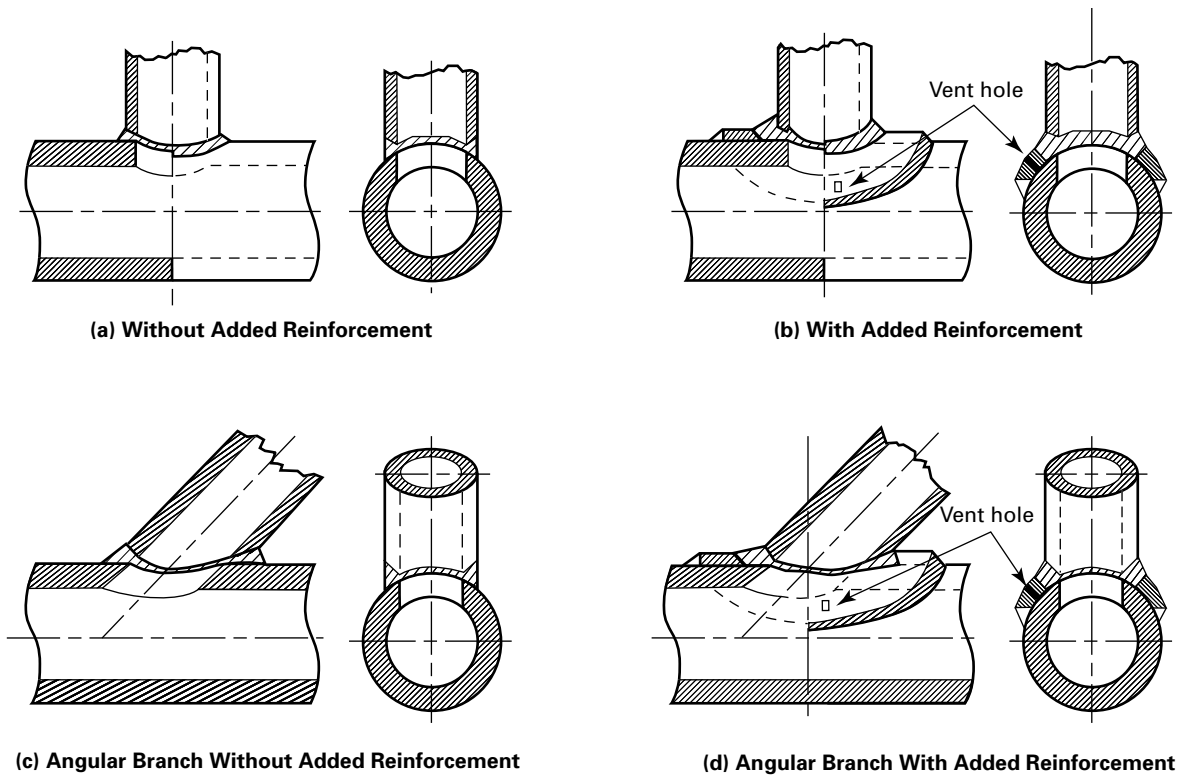


GENERAL NOTE: The weld deposit connecting the pipe end to the flange face at the I.D. shall not result in a weld buildup or undercut of the flange face surface.

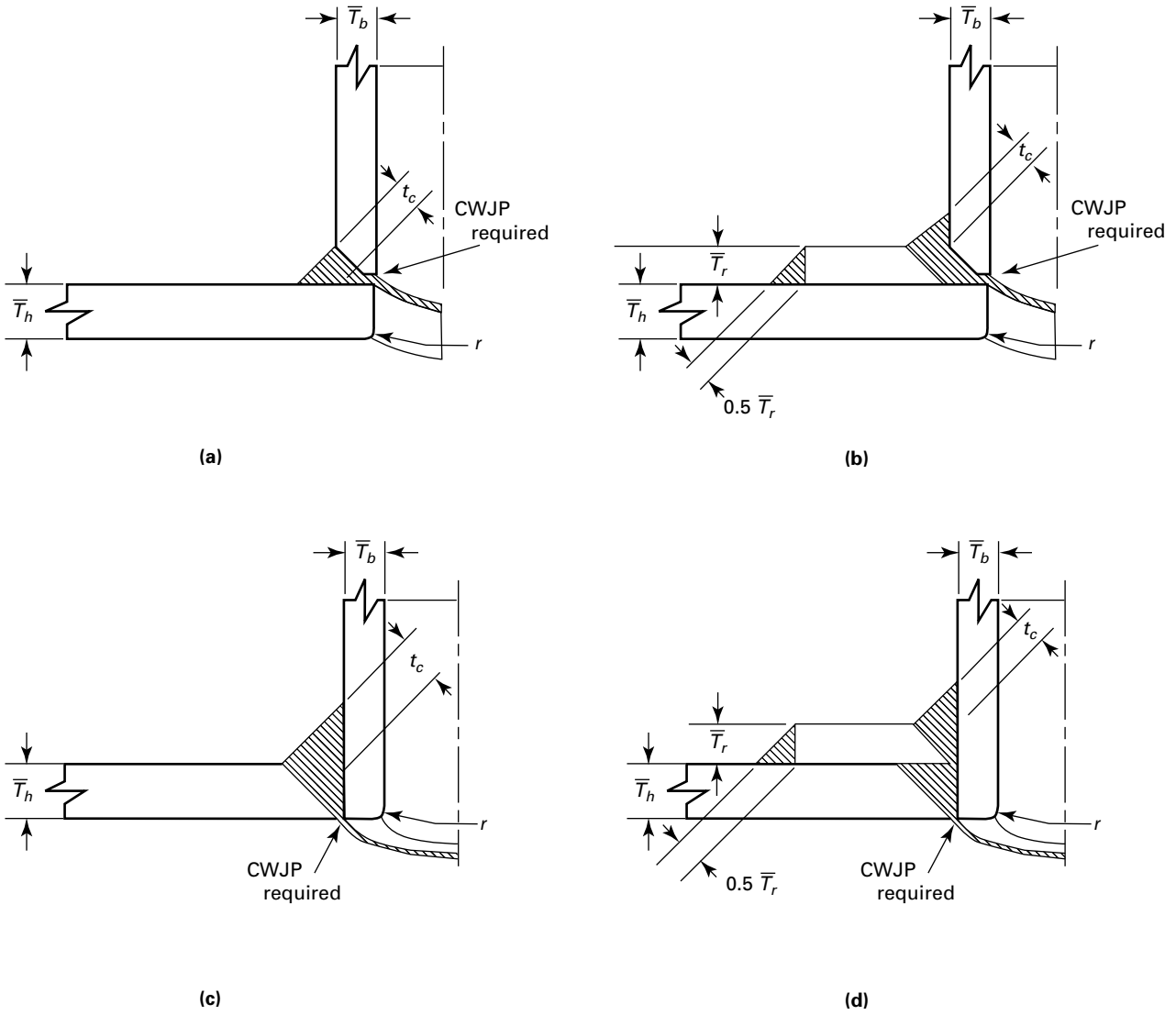
**Figure GR-3.4.7-3**  
**Minimum Welding Dimensions for Socket Welding Components to Pipe Including Fit-Up Detail**



**Figure GR-3.4.9-1**  
**Typical Welded Branch Connections**

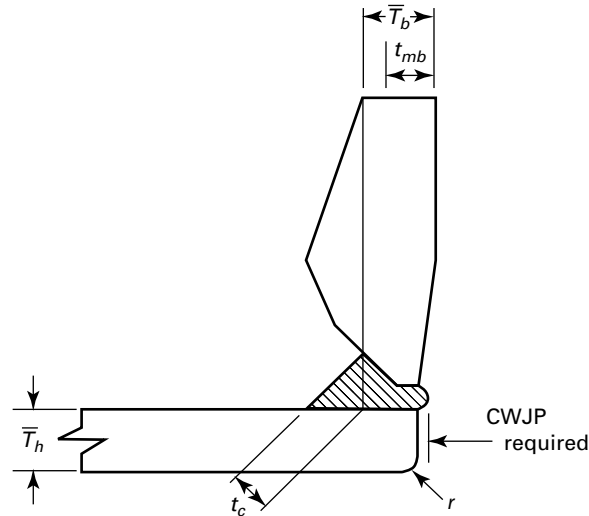


**Figure GR-3.4.9-2**  
**Acceptable Details for Pipe Branch Attachment Welds**



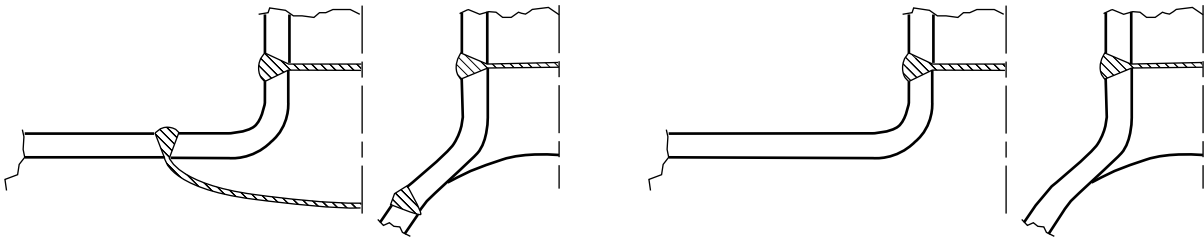
GENERAL NOTE: CWJP = complete weld joint penetration.

**Figure GR-3.4.9-3**  
**Acceptable Detail for Branch Connection of Pipe Fitting**



GENERAL NOTE: CWJP = complete weld joint penetration.

**Figure GR-3.4.9-4**  
**Acceptable Details for Branch Attachment Suitable for 100% Radiography**



**(a) Contour Outlet Fitting**

**(b) Extruded Header Outlet**

### GR-3.4.10 Mitered Joints

Mitered joints may be used in LH<sub>2</sub> piping systems under the following conditions:

(a) Full-penetration welds should be used in joining miter segments.

(b) A joint stress analysis has been performed, and the appropriate safety committee has approved.

(c) The number of full-pressure or thermal cycles will not exceed 7,000 during the expected lifetime of the pipe system.

### GR-3.4.11 Fabricated or Flared Laps

Fabricated or flared laps are not permitted. Only forged laps are permitted.

### GR-3.4.12 Attachment Welds

Structural attachments may be made by complete penetration, partial penetration, or fillet welds.

Low energy capacitor discharge welding may be used for the welding of temporary attachments directly to pressure parts provided that they be removed prior to subjecting the piping system to operating pressure or temperature. After their removal, the affected areas shall be examined by visual, MT, or PT in accordance with the requirements of Part GR and the specific requirements of Part IP or Part PL. Welding procedures and personnel qualifications are required.

This method of welding may also be used for the permanent attachment of nonstructural items, such as strain gages or thermocouples, provided that

**Table GR-3.5-1  
Preheat Temperatures**

(23)

| Base Metal<br>P-No. or S-No.<br>[Note (1)] | Base Metal Group                        | Nominal Thickness<br>[Note (2)] |      | Specified Min. Tensile<br>Strength, Base Metal |     | Minimum Preheat<br>Temperature<br>Required<br>[Note (3)] |     |
|--|---|---------------------------------|------|--|-----|--|-----|
|  |   | mm                              | in.  | MPa  | ksi | °C   | °F  |
| 1  | Carbon steel                            | <25                             | <1   | ≤490   | ≤71 | 10   | 50  |
|  |   | ≥25                             | ≥1   | All  | All | 80   | 175 |
|  |   | All                             | All  | >490   | >71 | 80   | 175 |
| 3  | Alloy steels,<br>Cr ≤ 1/2%              | <13                             | <1/2 | ≤490   | ≤71 | 80   | 175 |
|  |   | ≥13                             | ≥1/2 | All  | All | 80   | 175 |
|  |   | All                             | All  | >490   | >71 | 80   | 175 |
| 4  | Alloy steels,<br>1/2% < Cr ≤ 2%         | All                             | All  | All  | All | 150  | 300 |
| 5A, 5B                                     | Alloy steels,<br>2 1/4% ≤ Cr ≤ 9Cr max. | All                             | All  | All  | All | 175  | 350 |
| Note (4)                                   | Nonferrous                              | All                             | All  | All  | All | 24   | 75  |

## NOTES:

- (1) P-Number or S-Number from ASME BPVC, Section IX, QW/QB-422.  
(2) See para. GR-3.6.2 for governing thickness.  
(3) Preheat and interpass temperature shall be as specified/qualified per the applicable WPS/PQR.  
(4) Nonferrous materials minimum preheat and maximum interpass shall be per the applicable WPS/PQR.

(a) a WPS is prepared, describing the capacitor discharge equipment, materials to be joined, and techniques of application. The qualification of the procedure is required.

(b) the minimum thickness of the material to which the attachment is to be made is 2.3 mm (0.090 in.).

(c) the power input is based on the equipment manufacturer's recommendation or limits.

#### GR-3.4.13 Requirement for Fabricating and Attaching Pipe Supports

(a) Fabrication of standard pipe hangers and supports shall be in accordance with the requirements of MSS SP-58 and the specific requirements of Part IP or Part PL. Special hangers, supports, anchors, and guides, not defined as standard types of hanger components in MSS SP-58, shall be welded in accordance with the specific requirements of Parts IP and PL.

(b) Attachment welds for hangers, supports, guides, and anchors to the piping system shall conform to the specific requirements of Parts IP and PL.

(c) Welding requirements for fabrication and erection shall be in accordance with para. GR-3.2.4, using the specified/qualified WPS/PQR, along with qualified welders and welding operators.

(d) Examination of weldments, and fabricating and attaching pipe supports, shall be in accordance with Chapter GR-4 and the specific requirements of Part IP or Part PL.

#### GR-3.5 PREHEATING FOR WELDMENTS

Preheating is used, along with heat treatment, to minimize the detrimental effects of high temperature and severe thermal gradients inherent in welding. The necessity for preheating and the temperature to be used shall be specified in the engineering design and demonstrated by procedure qualification. The requirements and recommendations herein apply to all welding methods and processes and their applications.

(a) *Requirements.* Required minimum preheat temperatures for materials based on the P-Numbers are given in Table GR-3.5-1.

(b) *Unlisted Materials.* Preheat requirements for an unlisted material shall be specified/qualified in the WPS/PQR.

(c) *Temperature Verification*

(1) Preheat temperature shall be checked by use of temperature-indicating crayons, thermocouple pyrometers, or other suitable means to ensure that the temperature specified in the WPS is obtained prior to and maintained during welding.

**Table GR-3.6.1-1**  
**Requirements for Postweld Heat Treatment of Weldments**

| Base Metal<br>P-No. or S-No.<br>[Note (1)] | Base Metal Group                 | Nominal<br>Thickness<br>[Note (2)] |                               | Specified Min.<br>Tensile<br>Strength,<br>Base Metal |     | Metal<br>Temperature Range |                 | Holding Time               |     |                    |
|--|----------------------------------|------------------------------------|-------------------------------|--|-----|----------------------------|-----------------|----------------------------|-----|--------------------|
|  |                                  | mm                                 | in.                           | MPa  | ksi | °C                         | °F              | Nominal Wall<br>[Note (3)] |     | Min.<br>Time,<br>h |
| 1  | Carbon steel                     | ≤20                                | ≤ <sup>3</sup> / <sub>4</sub> | All  | All | None [Note (4)]            | None [Note (4)] | ...                        | ... | ...                |
|  |                                  | >20                                | > <sup>3</sup> / <sub>4</sub> | All  | All | 595–650                    | 1,100–1,200     | 2.4                        | 1   | 1                  |
| 3  | Alloy steels, Cr ≤ 1/2%          | ≤20                                | ≤ <sup>3</sup> / <sub>4</sub> | ≤490   | ≤71 | None [Note (4)]            | None [Note (4)] | ...                        | ... | ...                |
|  |                                  | >20                                | > <sup>3</sup> / <sub>4</sub> | All  | All | 595–720                    | 1,100–1,325     | 2.4                        | 1   | 1                  |
|  |                                  | All                                | All                           | >490   | >71 | 595–720                    | 1,100–1,325     | 2.4                        | 1   | 1                  |
| 4 [Note (5)]                               | Alloy steels, 1/2% < Cr ≤ 2%     | All                                | All                           | All  | All | 705–745                    | 1,300–1,375     | 2.4                        | 1   | 1                  |
| 5A, 5B [Note (5)]                          | Alloy steels (2 1/4% ≤ Cr ≤ 10%) | All                                | All                           | All  | All | 705–760                    | 1,300–1,400     | 2.4                        | 1   | 1                  |
| 8  | High alloy steels, austenitic    | All                                | All                           | All  | All | None                       | None            | ...                        | ... | ...                |

## GENERAL NOTES:

- (a) PWHT cycle shall be supported by the specified/qualified WPS/PQR.  
 (b) Part PL PWHT weldments of P-No. 1 or S-No. 1 materials shall be exempted up to and including 32 mm (1 1/4 in.) thickness.

## NOTES:

- (1) P-Number or S-Number from ASME BPVC, Section IX, QW/QB-422.  
 (2) See para. GR-3.6.2 for governing thickness.  
 (3) For holding time in SI metric units, use min/mm (minutes per mm) thickness. For U.S. units, use hr/in. thickness.  
 (4) PWHT may be required to meet the hardness requirement in Table IP-10.4.3-2.  
 (5) Temperatures listed for some P-Nos. 4, 5A, and 5B materials may be higher than the minimum tempering temperatures specified in the ASTM specifications for the base material. For higher-strength normalized and tempered materials, there is consequently a possibility of reducing tensile properties of the base material, particularly if long holding times at the higher temperatures are used.

(2) Thermocouples may be temporarily attached directly to pressure-containing parts using the capacitor discharge method of welding. WPS and performance qualification are required. After thermocouples are removed, the areas shall be examined by NDE visual and PT or MT for evidence of defects to be repaired.

(d) *Preheat Zone.* The preheat zone shall extend at least 25 mm (1 in.) beyond each edge of the weld.

(e) *Temperature Maintenance.* The temperature shall not fall below the prescribed minimum preheat temperature during welding.

(f) *Specific Requirements*

(1) *Dissimilar Materials.* When materials having different preheat requirements are welded together, it is recommended that the higher temperature shown in Table GR-3.5-1 be used.

(2) *Interrupted Welding.* If welding is interrupted, the rate of cooling shall be controlled or other means shall be used to prevent detrimental effects in the piping. The preheat specified in the WPS shall be applied before welding is resumed.

**GR-3.6 HEAT TREATMENT**

Heat treatment is used to avert or relieve the detrimental effects of high temperature and severe temperature gradients inherent in welding and to relieve residual stresses created by bending and forming. Provisions in para. GR-3.9 are basic practices that are suitable for most bending and forming operations but not necessarily appropriate for all service conditions. See Nonmandatory Appendix A for a discussion of when additional heat treatment should be considered.

**GR-3.6.1 PWHT Requirements**

(a) PWHT shall be in accordance with para. GR-3.6, Table GR-3.6.1-1, the requirements found in Parts IP and PL, and the engineering design.

(b) PWHT to be used for production weldments shall be specified/qualified in the designated WPS/PQR.

(c) See para. GR-3.7 for specific and alternative heat treat requirements.

**GR-3.6.2 Governing Thickness**

For preheat and PWHT, the term “nominal thickness” is the thickness of the weld as defined below.

(a) groove welds (girth and longitudinal) — thickness including maximum reinforcement allowed by Table GR-3.4.6-1 or the actual measured reinforcement, whichever is less.

(b) fillet welds — the throat thickness of the weld.

(c) partial penetration welds — the depth of the weld groove, plus throat thickness of cover weld.

(d) repair welds — in material or weld deposit, the depth of the repair cavity plus the weld reinforcement thickness.

(e) in the case of branch connections, metal (other than weld metal) added as reinforcement, whether an integral part of a branch fitting or attached as a reinforcing pad or saddle, shall not be considered in determining heat treatment requirements. Heat treatment is required, however, when the thickness through the weld in any plane through the branch is greater than twice the minimum material thickness requiring heat treatment, even though the thickness of the components at the joint is less than the minimum thickness. Thickness through the weld for the details shown in Figures GR-3.4.9-2 and GR-3.4.9-3 shall be computed using the following formulas:

(1) illustration (a) =  $\bar{T}_b + t_c$

(2) illustration (b) = greater of  $\bar{T}_b + t_c$  or  $\bar{T}_r + t_c$

(f) in the case of fillet welds at double welded slip-on flanges and piping connections DN 50 (NPS 2) and smaller, for seal welding of threaded joints in piping DN 50 (NPS 2) and smaller, and for attachment of external nonpressure parts such as lugs or other pipe-supporting elements in all pipe sizes, heat treatment is required when the thickness through the weld in any plane is more than twice the minimum material thickness requiring heat treatment (even though the thickness of the components at the joint is less than that minimum thickness), except as follows:

(1) not required for P-No. 1 materials when weld throat thickness is 16 mm ( $\frac{5}{8}$  in.) or less, regardless of base metal thickness.

(2) not required for P-No. 3, 4, 5A, or 5B materials when weld throat thickness is 13 mm ( $\frac{1}{2}$  in.) or less, regardless of base metal thickness, provided that not less than the recommended preheat is applied and the specified minimum tensile strength of the base metal is less than 490 MPa (71 ksi).

(3) not required for ferritic materials when welds are made with filler metal that does not air harden. Austenitic welding materials may be used for welds to ferritic materials when the effects of service conditions, such as differential thermal expansion due to elevated temperature, or corrosion, will not adversely affect the weldment.

### GR-3.6.3 Dissimilar Materials

(a) PWHT of welded joints between dissimilar ferritic metals or ferritic metals using dissimilar ferritic filler metal shall be at the higher of the temperature ranges in Table GR-3.6.1-1 for the materials in the joint.

(b) PWHT of welded joints including both ferritic and austenitic components and filler metals shall be as required for the ferritic material or materials unless otherwise specified in the engineering design.

### GR-3.6.4 Methods of Heating

The heating method shall provide the heating cycle for maintaining the required metal temperature, uniformity, and control.

(a) *Furnace Heating.* Fuel gas or electric shall be allowed.

(1) Heating an assembly in a furnace should be used when practical; however, the size or shape of the unit or the adverse effect of a desired heat treatment on one or more components, where dissimilar materials are involved, may dictate alternative procedures.

(2) An assembly may be postweld heat treated in more than one heat in a furnace, provided there is at least a 300 mm (1 ft) overlap of the heated sections and the portion of the assembly outside the furnace is shielded so that the temperature gradient is not harmful.

(3) Direct impingement of flame on the assembly is prohibited.

(b) *Local Heating.* Fuel gas, electrical induction, or resistance shall be allowed.

(1) Welds may be locally PWHT by heating a circumferential band around the entire component with the weld located in the center of the band. The width of the band heated to the PWHT temperature for girth welds shall be at least 3 times the wall thickness at the weld of the thickest part being joined.

(2) For nozzle and attachment welds, the width of the band heated to the PWHT temperature shall extend beyond the nozzle weld or attachment weld on each side at least 2 times the header thickness and shall extend completely around the header.

(3) Where the nozzle or attachment weld heating band includes a girth weld or a bent or formed section, the heat band shall extend at least 25 mm (1 in.) beyond the ends thereof.

### GR-3.6.5 PWHT Heating and Cooling Requirements

Above 335°C (600°F), the rate of heating and cooling shall not exceed 335°C/h (600°F/hr) divided by one-half the maximum thickness of material in inches at the weld, but in no case shall the rate exceed 335°C/h (600°F/hr). The cooling cycle shall provide the required or desired cooling rate and may include cooling in a furnace, in still air, by application of local heat or insulation, or by other suitable means.

### GR-3.6.6 Temperature Verification

Record of the heat treatment temperature cycle shall be monitored by attached thermocouple pyrometers or other suitable methods to ensure that the requirements are met. See [para. GR-3.4.12](#) for attachment of thermocouples by the capacitor discharge method of welding.

### GR-3.6.7 Delayed Heat Treatment

If a weldment is allowed to cool prior to heat treatment, the rate of cooling shall be controlled, or other means shall be used to prevent detrimental effects in the piping.

### GR-3.6.8 Partial Heat Treatment

When an entire piping assembly to be heat treated cannot be fitted into the furnace, it is permissible to heat treat in more than one heat, provided there is at least 300 mm (1 ft) overlap between successive heats and that parts of the assembly outside the furnace are protected from harmful temperature gradients.

## GR-3.7 SPECIFIC AND ALTERNATIVE HEAT TREAT REQUIREMENTS

When warranted by experience or knowledge of service conditions, alternative methods of heat treatment or exceptions to the basic heat treatment provisions of [para. GR-3.6.1](#) may be adopted as provided in [paras. GR-3.7.1](#) and [GR-3.7.2](#).

### GR-3.7.1 Exceptions to Basic Requirements

In some cases, as indicated in [para. GR-3.6](#), basic practices may require modification to suit service conditions. In such cases, the engineering design may specify more stringent requirements, including heat treatment and hardness limitations for lesser thickness, or may specify less stringent heat treatment and hardness requirements, including none.

When provisions less stringent than those in [para. GR-3.6](#) are specified, the engineering design must demonstrate to the owner's satisfaction the adequacy of those provisions

(a) by comparable service experience, considering service temperature and its effects, frequency and intensity of thermal cycling, flexibility stress levels, probability of brittle failure, and other pertinent factors or

(b) by demonstrating that the base metal, welds, and HAZ would be adversely affected by the otherwise required heat treatment

In addition, appropriate tests shall be conducted, including WPS qualification tests.

### GR-3.7.2 Alternative Heat Treatment

Normalizing, normalizing and tempering, or annealing may be applied in lieu of the required heat treatment after welding, bending, or forming, provided that the mechanical properties of any affected weld and base metal meet specification requirements after such treatment and that the substitution is approved by the engineering design.

## GR-3.8 CONSTRUCTION OF BRAZEMENTS

The construction of brazements shall include the following:

(a) brazed piping components shall be allowed to be used for services within temperature limits specified by the engineering design.

(b) brazed joint connections for fabrication and erection of piping components (see [Figure GR-3.8-1](#)).

(c) repair of defective brazements.

(d) brazed joints of test specimens required for all qualification of procedures and brazers.

(e) each qualified brazer shall be assigned an identification symbol. Unless otherwise specified in the engineering design, each pressure-containing brazement or adjacent area shall be marked with the identification symbol of the brazers. In lieu of marking the brazement, appropriate records shall be filed.

(f) brazing shall not be performed when the temperature of the metal surface within 305 mm (12 in.) of the point of brazing in all directions is lower than 16°C (60°F). The work area and surfaces to be brazed shall be protected from wind and moisture conditions caused by ice, rain, snow, and running or standing water.

(g) valve end connections requiring brazing shall consider procedures to preserve the seat tightness of the valve.

(h) fuel heating methods and gases shall be as specified/qualified by a BPS/PQR.

### GR-3.8.1 Brazed Joint Type

All brazed joint designs shall be suitable for the intended critical service of hydrogen applications. There are two basic types: lap and butt.

(a) The lap joint for tubular parts requires the selection of preformed fittings, such as couplings, reducers, elbows, and flanges [see [Figure GR-3.8-1](#), illustration (a)].

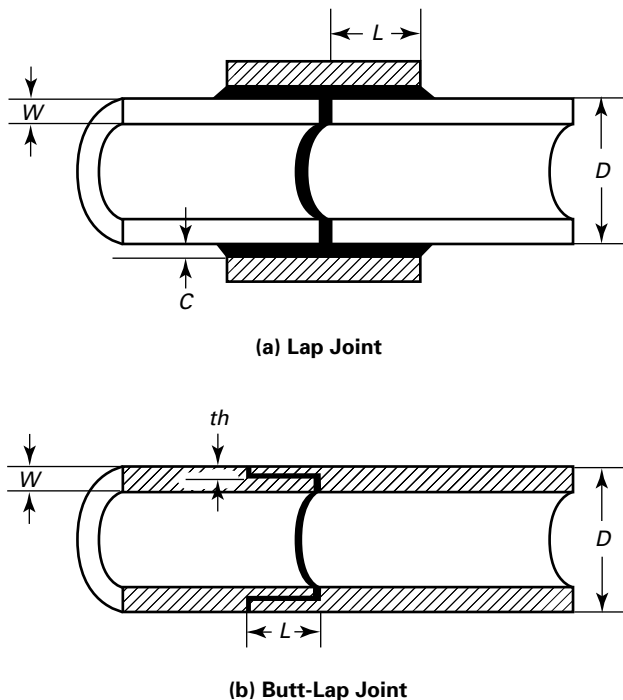
(b) Butt-lap joint for tubular parts requires a machining preparation to develop a socket type of connection [see [Figure GR-3.8-1](#), illustration (b)].

### GR-3.8.2 Couplings With Internal Stops

All couplings (fittings) for newly constructed and repair brazements shall be manufactured with internal stops. The stops shall control the internal gap between the pipe component ends. For requirements of brazed joint pressure fittings, see ASME B16.50.



**Figure GR-3.8-1**  
**Joints for Tubular Components**



Legend:

- $C$  = joint clearance
- $D$  = diameter of lap area
- $F$  = shear strength of brazed filler metal
- $J$  = joint integrity factor of 0.8
- $L$  = length of lap area  
=  $[W(D - W)T]/JFD$
- $T$  = tensile strength of weakest member
- $th$  = thickness of thinner joint member
- $W$  = wall thickness of weakest member

### GR-3.8.3 Repairs

Brazed joints that have been found to be defective may be rebrazed, where feasible, after thorough cleaning, by employing the same brazing procedure used for the original brazement.

### GR-3.8.4 Precleaning and Surface Prep

Internal and external surfaces to be brazed shall be properly cleaned. The requirements apply to all base materials and the filler metal.

(a) Chemical surface cleaning shall be used to remove contaminants that prohibit quality brazing. The affected surfaces shall be free from paint, oil, rust, scale, grease, slag, oxides, and other deleterious material that would be detrimental to the base metal.

(b) *Mechanical Surface Preparation*

(1) Mechanical surface preparation shall be performed by wire brushing, grinding, buffing, and polishing when required, to remove harmful defects such as fissures, pits, gouges, folds, laps, or oxides.

(2) Such methods are also used for removing objectionable surface conditions, roughening faying surfaces, and preparation.

(3) If a power-driven wire wheel is used, care should be exercised to prevent burnishing. Burnishing can result in surface oxide embedment, which interferes with the proper wetting of the base metal by the filler metal. A base metal surface that is too smooth may not effectively allow filler metal wetting of the faying surfaces.

(c) The method and extent of cleaning, removal, and preparation shall be determined based on the specified material of pipe components. The method shall not be detrimental to the specified base materials or pipe components. The type of acceptable cleaning materials shall be included in the engineering design specifications.

(d) Braze stop-off shall not be used unless approved by the engineering design.

### GR-3.8.5 Joint Preparation, Alignment, and Brazing

(23)

(a) *Preparation of Pipe Component Ends.* Mechanical cutting and machining methods shall be applicable to the specified base material of pipe components. The methods shall be specific to the material type, such as copper, copper alloys, and austenitic stainless steels.

(b) *Preparation of Joints*

(1) The ends to be brazed with filler metal shall be prepared by machining or facing to provide a square end or joint detail that meets the requirements of Figure GR-3.8-1.

(2) The brazed joints shall be properly cleaned, along with the areas of the inside and outside surfaces for a minimum distance of 25 mm (1 in.).

(c) *Alignment for Brazing*

(1) Alignment using mechanical alignment tools may be used to maintain alignment of the joint to be brazed.

(2) The joint clearance shall be maintained within the specified limits of the BPS/PQR to achieve the proper capillary action to distribute the molten filler metal between the surfaces of the base metal during the brazing operation.

(3) The specified lap of each joint type shall be fully inserted for alignment and maximum strength at the joint.

(d) *Joint Brazing.* All brazements for hydrogen service shall be considered critical. The following requirements shall apply:

(1) Brazed joints are limited to tubular lap or butt-lap joints and shall meet the more stringent requirements of this Code or the engineering design. See [Nonmandatory Appendix A, para. A-3.3](#) for a discussion of AWS C3.3, Recommended Practices for the Design, Manufacture, and Examination of Critical Brazed Components.

(2) Use brazed fittings manufactured in accordance with ASME B16.50.

(3) Manually apply the brazing filler metal by face-feeding into the joint. Preplaced brazing filler metal may be in the form of rings, strips, or shims. Visual observation after brazing shall show the required penetration and filler on both sides of the joint.

(4) The joint must allow for proper purge gas backing of the pipe component I.D. when required.

(5) Specified fluxes shall be applied to the joint surfaces to promote wetting and prevent oxide formation during the brazing operation.

(6) All brazed joints shall have complete penetration, whether brazed from one side or from both sides.

### GR-3.8.6 Brazing Fluxes

Brazing fluxes shall be applied to remove oxides and contaminants from base materials to ensure good-quality brazed joints. They remove only surface oxides and tarnish; other contaminants (oil, grease, lubricants, and protective coating) must be removed either mechanically or chemically before brazing.

(a) Flux selection shall be based on

(1) base material type.

(2) filler material type.

(3) flux temperature range. For manual torch brazing, select a flux that is active at 56°C (100°F) below the solidus of the brazing filler metal and that remains active up to 167°C (300°F) above the filler metal liquidus.

Flux performance is affected by the brazing time and temperature. To control flux exhaustion, prolonged heating cycles and heating above the flux temperature limits shall be avoided.

(b) *Flux Application.* To protect the surfaces to be brazed effectively, the flux must completely cover and protect them until the brazing temperature is reached. It must remain active throughout the brazing cycle, since the molten filler metal should displace the flux from the joint at the brazing temperature.

(1) Flux shall be applied to the joint faces and adjacent surfaces.

(2) Excess flux will not compromise joint quality and provide for flux removal, since residues will be less loaded with metal oxide and more soluble in water.

(3) Applying flux to surfaces adjacent to the joint helps prevent oxidation of the workpiece and may act as a flux reservoir, draining flux into joint.

(4) Using too little flux, however, can lead to premature flux exhaustion and inadequate coverage, producing unsound or unsightly brazed joints.

### GR-3.8.7 Brazing Process

(a) *Torch Brazing.* The required heat for the brazing cycle shall be produced by a controlled fuel gas flame. The fuel gas (e.g., acetylene, propane, or natural gas) is to be combusted with air, compressed air, or oxygen. The specific combination selected is dependent on the amount of heat required to bring the particular components to the brazing temperature in the required time.

(b) Equipment (e.g., gages, hoses, torch body, and tip) shall be suitable in design and construction for the particular application. It shall be capable of producing a neutral or reducing flame and shall produce uniform heating of the joint area. Multiple heating tips may be used to progressively raise the pipe component temperature for brazing.

(c) *Brazing Cycle.* The brazing time and temperature shall be controlled within the following requirements:

(1) using a neutral flame

(2) uniform heating of components to the brazing temperature

(3) care not to remove flux from the components by the force of the flame

(4) brazing temperature (filler metal liquidus) shall be held for the minimum time required to produce a satisfactory joint

(5) controlling the time and temperature of the brazing cycle shall be such as to

(-a) effect the capillary flow (wetting action) of the filler metal alloying of the base metal component surfaces

(-b) limit excessive dilution of the filler into the base metal, promoting base metal erosion and formation of brittle compounds, which leads to a loss of base metal ductility

### GR-3.8.8 Post-Braze Cleaning

(a) Completed brazed joint cleaning shall include the removal of all flux residue, oxides, and other surface contaminants to allow for inspection/examination.

(b) The method and extent of cleaning and removal shall be determined based on the specified base material and filler metal. The method of cleaning or removal shall not be detrimental to the base material or brazed deposit.

### GR-3.9 FORMING OF PIPE COMPONENTS

Pipe may be bent and components may be formed by any hot or cold method that is suitable for the material, the intended service, and the severity of the bending or forming process. When selecting material for hydrogen service, consideration shall be given to the effects of cold working, which may promote lower resistance to HE, while hot working enhances resistance to HE. The finished surface shall be free of cracks and substantially free from buckling. Thickness after bending or forming shall be not less than that required by the engineering design.

**GR-3.9.1 Bending Requirements**

(a) *Flattening.* Flattening of a bend, the difference between maximum and minimum diameters at any cross section, shall not exceed 8% of nominal outside diameter for internal pressure and 3% for external pressure. Removal of metal shall not be used to achieve these requirements.

(b) *Bending Temperature*

(1) Cold bending of ferritic materials shall be done at a temperature below the transformation range.

(2) Hot bending shall be done at a temperature above the transformation range and in any case within a temperature range consistent with the material and the intended service.

(c) *Corrugated and Other Bends.* Dimensions and configuration shall conform to a design qualified in accordance with para. IP-3.8.2 or para. PL-3.7, as applicable.

(d) *Hot Bending and Forming.* After hot bending and forming, heat treatment is required for P-Nos. 1, 3, 4, 5A, and 5B materials in all thicknesses. Durations and temperatures shall be in accordance with Table GR-3.6.1-1.

(e) *Cold Bending and Forming.* After cold bending and forming, heat treatment is required (for all thicknesses, and with temperature and duration as given in Table GR-3.6.1-1) when any of the following conditions exist:

(1) for P-Nos. 1 through 5A and 5B materials, where the maximum calculated fiber elongation after bending or forming exceeds 50% of specified basic minimum elongation (in the direction of severest forming) for the applicable specification, grade, and thickness. This requirement may be waived if it can be demonstrated that the selection of pipe and the choice of bending or forming process provide assurance that, in the finished condition, the most severely strained material retains at least 10% elongation.

(2) for any material requiring impact testing, where the maximum calculated fiber elongation after bending or forming will exceed 5%.

(3) when specified in the engineering design.

(23) **GR-3.9.2 Post-Heat Treatment**

Post-heat treatment, when required for pipe components after bending or forming, shall be performed in accordance with para. GR-3.6, including Table GR-3.6.1-1.

**GR-3.10 HARDNESS TESTING**

Hardness testing shall be conducted for welding procedure qualification tests for those materials with acceptance criteria described in Table GR-3.10-1. Base metal for welding procedure qualification tests shall be made from the same base metal specification (same P-Number and Group Number), similar in chemistry, and in the same heat treatment condition as specified for the piping. The thickness of base metal coupons shall not be less than the piping.

(a) *Method*

(1) The hardness survey shall be performed on a transverse weld cross section that has been polished and etched to identify the weld metal, fusion line, and HAZ.

(2) The hardness test shall be carried out in accordance with ASTM E92 using a 10-kg load. Other hardness testing methods for welding procedure qualification may be used when permitted by the engineering design.

(3) Two Vickers hardness traverses of the weld joint should be made on a weld sample in the minimum PWHT condition. These hardness traverses should be performed at 1.5 mm ( $\frac{1}{16}$  in.) from the internal and external surfaces as shown in Figure GR-3.10-1. The HAZ readings should include locations as close as possible [approximately 0.2 mm (0.008 in.)] to the weld fusion line. Each traverse includes 10 hardness readings for a total of 20 hardness readings per weld sample.

(b) *Acceptance Criteria*

(1) Hardness measurements shall not exceed the limits of Table GR-3.10-1 after the required PWHT. Other hardness testing limits may be used if specified in the engineering design.

(2) The hardness data shall be reported on the PQR.

(3) A separate test coupon may be welded following an existing WPS to satisfy the requirements in Table GR-3.10-1.

**Table GR-3.10-1  
Hardness Testing Acceptance Criteria**

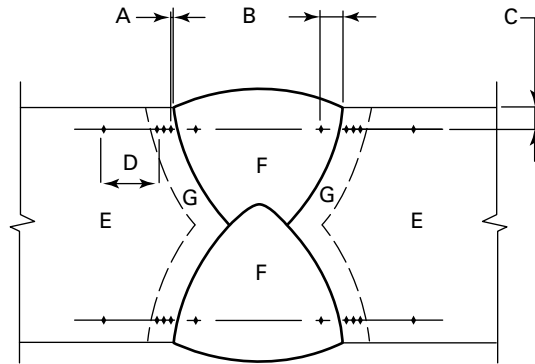
| Base Metal P-No.<br>[Note (1)] | Base Metal Group                     | Vickers HV 10 Max. Hardness<br>[Note (2)] |
|--------------------------------|--------------------------------------|---|
| 1                              | Carbon steel                         | 235                                       |
| 3                              | Alloy steels, Cr $\leq$ 1/2%         | 235                                       |
| 4                              | Alloy steels, 1/2% < Cr $\leq$ 2%    | 235                                       |
| 5A, 5B                         | Alloy steels, 2 1/4% < Cr $\leq$ 10% | 248                                       |

NOTE:

(1) P-Number from ASME BPVC, Section IX, QW/QB-422.

(2) When other hardness testing methods are used, the acceptance criteria shall be equivalent to these Vickers HV 10 values.

**Figure GR-3.10-1**  
**Location of Vickers Hardness Indentations**



Legend:

- A = approximately 0.2 mm (0.008 in.)
- B = 1 mm - 3 mm (0.04 in. - 0.12 in.) (Typ.)
- C = 1.5 mm (<sup>1</sup>/<sub>16</sub> in.)
- D = 3 mm - 6 mm (0.12 in. - 0.24 in.) (Typ.)
- E = base metal
- F = weld metal
- G = HAZ

# Chapter GR-4

## Inspection, Examination, and Testing

### GR-4.1 GENERAL

This Code distinguishes between inspection (see [para. GR-4.2](#)), examination (see [para. GR-4.3](#)), and testing (see [para. GR-4.11](#)). Inspection applies to functions performed for the owner by the owner's Inspector or the Inspector's delegates. References in this Code to the "Inspector" are to the owner's Inspector or the Inspector's delegates.

### GR-4.2 INSPECTION

#### GR-4.2.1 Responsibility

It is the owner's responsibility, exercised through the owner's Inspector, to verify that all required examinations and testing have been completed and to inspect the piping to the extent necessary to be satisfied that it conforms to all applicable examination requirements of this Code and of the engineering design.

#### GR-4.2.2 Rights of the Owner's Inspector

The owner's Inspector and the Inspector's delegates shall have access to any place where work concerned with the piping installation is being performed. This includes manufacture, fabrication, heat treatment, assembly, erection, examination, and testing of the piping or pipelines. They shall have the right to audit any examination, to inspect the piping or pipelines using any examination method specified by the engineering design, and to review all certifications and records necessary to satisfy the owner's responsibility stated in [para. GR-4.2.1](#).

#### GR-4.2.3 Qualifications of the Owner's Inspector

(a) The owner's Inspector shall be designated by the owner and shall be the owner, an employee of the owner, an employee of an engineering or scientific organization, or an employee of a recognized insurance or inspection company acting as the owner's agent. The owner's Inspector shall not represent nor be an employee of the manufacturer, fabricator, or erector unless the owner is also the manufacturer, fabricator, or erector.

(b) The owner's Inspector shall have not less than 10 yr of experience in the design, fabrication, or inspection of industrial piping or pipelines. Each 20% of satisfactorily

completed work toward an engineering degree recognized by the Accreditation Board for Engineering and Technology (ABET)<sup>1</sup> shall be considered equivalent to 1 yr of experience, up to 5 yr total.

(c) In delegating performance of inspection, the owner's Inspector is responsible for determining that a person to whom an inspection function is delegated is qualified to perform that function.

### GR-4.3 EXAMINATION

Examination applies to quality control functions performed by the manufacturer (for components only), fabricator, or erector. Reference in this Code to an "examiner" is to a person who performs quality control examinations. In addition, NDE such as VT, RT, UT, PT, and MT, used as defined in [para. GR-4.3.4](#), shall meet the requirements of this Chapter.

#### GR-4.3.1 Responsibility

The construction organization (manufacturer, fabricator, or erector) shall be responsible for

(a) examinations applying to quality control functions  
 (b) ensuring the Examination System Qualification for NDE shall be in compliance with ASME BPVC, Section V, Article 14 and the applicable NDE methods; ASTM E1212; and the applicable requirements of this Code

(c) NDE procedures and personnel qualification/certification

(d) providing materials, components, and workmanship in accordance with the requirements of this Code and of the engineering design [see [para. GR-1.3\(b\)](#)]

(e) performing all required quality examinations, and NDE methods and testing

(f) preparing suitable records of examinations and tests for the Inspector's use

#### GR-4.3.2 Requirements

Prior to initial operation, each piping installation, including components and workmanship, shall be examined in accordance with the applicable requirements of [Part GR](#) and the specific requirements of [Part IP](#) or [Part PL](#), and to any greater extent specified by the engineering design. Weld joints not included in the extent of

<sup>1</sup> For more information, go to [www.abet.org](http://www.abet.org).

examinations required by [Part IP](#) or [Part PL](#) or by the engineering design are acceptable if they pass VT and the leak test required by [para. GR-4.11](#).

(a) When PWHT is required by this Code or the engineering design or both, final examination by RT or UT, when required, shall be performed after completion of any heat treatment.

(b) For a welded branch connection, the examination of and any necessary repairs to the pressure-containing weld shall be completed before any reinforcing pad or saddle is added.

(c) Examinations shall be performed in accordance with a written procedure that conforms to one of the following:

(1) quality control examinations based on the construction organization's Quality System Program

(2) NDE based on the requirements of this Code

(d) The employer shall certify records of the examination procedures employed, showing dates and results of procedure qualifications, and shall maintain them and make them available to the owner's Inspector.

#### GR-4.3.3 Quality Control Examinations

Quality control examinations shall include the requirements of the construction organization's Quality System Program for materials, products, components, workmanship, quality documents, procedures and personnel qualifications, construction, and subcontract services.

#### GR-4.3.4 Nondestructive Examination Methods

NDE required by this Code, by the engineering design, or by the owner's Inspector shall be performed in accordance with one of the methods specified herein.

(a) *Visual Examination.* VT shall be performed in accordance with the requirements of [Part GR](#), the specific requirements of [Part IP](#) or [Part PL](#), and ASME BPVC, Section V, Article 9. Records of individual visual examinations, which include in-process and final visual examination, are required.

(b) *Radiographic Examination.* RT of castings is covered in [para. IP-2.2.8](#). Radiography of welds and of components other than castings shall be performed in accordance with the requirements of [Part GR](#), the specific requirements of [Part IP](#) or [Part PL](#), and ASME BPVC, Section V, Article 2.

(c) *Ultrasonic Examination.* UT of castings is covered in [para. IP-2.2.8](#). UT of welds shall be performed in accordance with the requirements of [Part GR](#), the specific requirements of [Part IP](#) or [Part PL](#), and ASME BPVC, Section V, Article 5.

(d) *Liquid Penetrant Examination.* PT of castings is covered in [para. IP-2.2.8](#). PT of welds and of components other than castings shall be performed in accordance with the requirements of [Part GR](#), the specific requirements of [Part IP](#) or [Part PL](#), and ASME BPVC, Section V, Article 6.

(e) *Magnetic Particle Examination.* MT of castings is covered in [para. IP-2.2.8](#). MT of welds and of components other than castings shall be performed in accordance with the requirements of [Part GR](#), the specific requirements of [Part IP](#) or [Part PL](#), and ASME BPVC, Section V, Article 7.

(f) *Eddy Current Examination.* The method for eddy current examination of pipe and tubing shall follow the general guidelines of ASME BPVC, Section V, Article 8.

#### GR-4.3.5 Special Methods

If a method not specified herein is to be used, the acceptance criteria shall be specified in the engineering design (see [paras. GR-4.7](#) and [GR-4.8](#)).

### GR-4.4 PERSONNEL QUALIFICATION AND CERTIFICATION

(a) *Quality Control Qualification and Certification.* Personnel who perform quality control examinations shall have training and experience commensurate with the needs of the specified quality control function. The qualification and certification shall be in accordance with the applicable requirements of the construction organization's Quality System Program and documented procedures. Personnel who perform the quality control examination shall not perform the production work.

(b) *NDE Qualification and Certification.* Personnel who perform NDE shall have training and experience commensurate with the needs of the specified NDE method. The qualification and certification shall be in accordance with the applicable requirements of the employing construction organization's Quality System Program, including the written practice and documented procedures. Personnel who perform the NDE examination shall not perform the production work. This Code requires qualification of NDE personnel in accordance with ASME BPVC, Section V, Subsection A, Article 1, and one of the following:

(1) SNT-TC-1A, Personnel Qualification and Certification in Nondestructive Testing

(2) ANSI/ASNT CP-189, ASNT Standard for Qualification and Certification of Nondestructive Testing Personnel

(3) a national or international central certification program, such as the ASNT Central Certification Program (ACCP), which may be used to fulfill the examination requirements as specified in the employer's written practice

(c) The employing construction organization shall certify records of the quality control examiners and NDE personnel, showing dates and results of personnel qualifications, and shall maintain and make these records available to the owner's Inspector.



#### GR-4.5 EXTENT OF REQUIRED EXAMINATION AND TESTING

The extent of the examination and testing shall conform to the requirements of this Code or to any greater extent specified in the engineering design for specific hydrogen piping or pipeline systems.

#### GR-4.6 ACCEPTANCE CRITERIA

Acceptance criteria shall meet the applicable requirements specified in [Part IP](#) or [Part PL](#) and the engineering design.

#### GR-4.7 SUPPLEMENTARY EXAMINATION

Any of the examination methods described in [para. GR-4.3.4](#) may be specified by the engineering design to supplement the examination required by [Part IP](#) or [Part PL](#). Supplementary examination to be performed and any acceptance criteria that exceed the requirements in the applicable Part or Parts shall be specified in the engineering design.

#### GR-4.8 EXAMINATIONS TO RESOLVE UNCERTAINTY

Any method may be used to resolve doubtful indications. Acceptance criteria shall be that for the required examination in [Part IP](#) or [Part PL](#).

#### GR-4.9 DEFECTIVE COMPONENTS AND WORKMANSHIP

An examined item with one or more defects (imperfections of a type or magnitude exceeding the acceptance criteria of this Code) shall be repaired or replaced, and the new work shall be reexamined by the same methods, to the same extent, and by the same acceptance criteria as required for the original work.

#### GR-4.10 PROGRESSIVE SAMPLING FOR EXAMINATION

When required random examination reveals a defect, then

(a) two additional samples of the same kind (if welded or brazed joints, by the same welder, brazer, or operator) shall be given the same type of examination.

(b) if the items examined as required by (a) above are acceptable, the defective item shall be repaired or replaced and reexamined as specified, and all items represented by these two additional samples shall be accepted.

(c) if any of the items examined as required by (a) above reveals a defect, two further samples of the same kind shall be examined for each defective item found by that sampling.

(d) if all the items examined as required by (c) above are acceptable, the defective item(s) shall be repaired or replaced and reexamined as specified, and all items represented by the additional sampling shall be accepted.

(e) if any of the items examined as required by (c) above reveals a defect, all items represented by the progressive sampling shall be either

(1) repaired or replaced and reexamined as required, or

(2) fully examined and repaired or replaced as necessary, and reexamined as necessary to meet the requirements of this Code.

(f) if any of the defective items are repaired or replaced, reexamined, and a defect is again detected in the repaired or replaced item, continued progressive sampling in accordance with (a), (c), and (e) is not required based on the defects found in the repair. The defective item(s) shall be repaired or replaced and reexamined until acceptance as specified. Spot or random examination (whichever is applicable) is then performed on the remaining unexamined joints.

#### GR-4.11 TESTING

After construction of the piping system and after completion of the applicable examinations and repairs, but prior to the initial operation, each piping system shall be tested to ensure tightness. The test method and extent of testing shall be as required by the applicable [Part IP](#) or [Part PL](#).

(a) The tests shall be in accordance with the construction organization's Quality System Program and documented procedures.

(b) The construction organization's quality control examiner shall verify and maintain records of all tests.

(c) The owner's Inspector shall verify that the tests have been completed in accordance with the requirements of this Code and the engineering design.

#### GR-4.12 RECORDS

(a) *Responsibility.* It is the responsibility of the construction organization, the fabricator, and the erector, as applicable, to prepare the records required by the construction organization's Quality System Program, this Code, and the engineering design, along with the applicable requirements of ASME BPVC, Section V for the specific NDE methods.

(b) *Retention of Records.* Unless otherwise specified by the engineering design, records shall be retained for at least 5 yr after the record is generated for the project.

#### GR-4.13 NDE DEFINITIONS

The following terms apply to any type of examination:  
*100% examination:* complete examination of all of a specified kind of item in a designated lot of piping.

*complete examination:* required of the weldment, full pipe component circumferential, and longitudinal welds.

*designated lot:* that quantity of piping to be considered in applying the requirements for examination in this Code. The quantity or extent of a designated lot should be established by agreement between the contracting parties before the start of work. More than one kind of designated lot may be established for different kinds of piping work.

*random examination:* complete examination of a percentage of a specified kind of item in a designated lot of piping. Random examination will not ensure a fabrication product of a prescribed quality level throughout. Items not examined in a lot of piping represented by such examination may contain defects that further examination could disclose. Specifically, if all radiographically disclosable weld defects must be eliminated from a lot of piping, 100% RT must be specified.



## Chapter GR-5

# Operation and Maintenance

### GR-5.1 GENERAL

This Chapter references operating and maintenance procedures affecting the safety of hydrogen transmission and distribution facilities. Because of the many different hydrogen fluid services and many different types of piping and pipeline systems addressed by this Code, it is not possible to prescribe a detailed set of operating and maintenance procedures that will encompass all cases. It is possible, however, for each operating company to develop operating and maintenance procedures based on the provisions of this Code, its experience, and its knowledge of its facilities and conditions under which they are operated that will be adequate from the standpoint of public safety.

### GR-5.2 OPERATION AND MAINTENANCE PLAN

Each operating company having industrial piping, pipeline, and commercial and residential systems within the scope of this Code shall

(a) have a written plan covering operating and maintenance procedures in accordance with the requirements of this Code.

(b) have an emergency plan covering facility failure, accidents, leakage, and other emergencies.

(c) operate and maintain its facilities in conformance with these plans.

(d) modify the plans from time to time as experience dictates, and as exposure of the public to the facilities and changes in operating conditions require.

(e) provide training for employees in procedures established for their operating and maintenance functions. The training shall be comprehensive and designed to prepare employees for service in their area of responsibility.

(f) prepare and maintain records showing successful implementation of above items (a) through (e).

#### GR-5.2.1 Essential Features of the Operating and Maintenance Plan

(a) *Content.* The plan prescribed in para. GR-5.2(a) shall contain detailed instructions for employees covering operating and maintenance procedures for hydrogen facilities during normal operations and repairs, and either (1) or (2) as described below.

(1) items described in paras. GR-5.3, GR-5.12, and GR-5.18.

(2) integrity management program as prescribed in ASME B31.8S, as modified by (b) and (c) below. Plans shall give particular attention to those portions of the facilities presenting the greatest hazard to the public, either in the event of an emergency or because of construction or extraordinary maintenance requirements.

(b) *Integrity Management of Piping Systems.* The integrity management process for industrial piping shall use ASME B31.8S as a basis. ASME B31.8S was written to provide guidance for integrity management of pipeline systems, and therefore contains requirements, information, and terminology that are not always applicable to piping systems. Compatibility of all materials used with hydrogen shall be factored into the integrity management process. The guidance provided by ASME B31.8S shall be followed with modifications as stated in (1) through (5) below:

(1) The following suggested listing of failure mode factors for industrial piping shall be used in place of those listed in para. 2.2 of ASME B31.8S:

(-a) external corrosion

(-b) internal corrosion

(-c) hydrogen-induced cracking (HIC) and consequent reduction of physical properties

(-d) fatigue

(-e) manufacturing defects

(-1) defective pipe seam

(-2) defective pipe

(-f) welding/fabrication/erection related

(-1) defective pipe girth weld

(-2) defective attachment weld

(-3) defective pipe threads/flange facing

(-4) improperly hung/supported pipe

(-g) equipment

(-1) gasket, O-ring, packing failure

(-2) valve failure

(-3) pressure regulator failure

(-4) compressor, pump failure

(-h) mechanical damage

(-1) damage inflicted by first, second, or third party with immediate failure

(-2) damage with delayed failure

(-3) vandalism

(-i) operation

(-1) incorrect or inadequate operational procedure

(-2) operator error

(-j) weather related or outside force

(-1) cold/hot weather

(-2) heavy rain/flood

(-3) lightning

(-4) windstorm

(-5) earth movement

This listing is for illustrative purposes and may not be a complete listing of specific piping system threats.

(2) Hydrostatic test pressure (TP) shall be limited to the pressure calculated per [para. IP-10.6.2](#). The maximum testing interval shall be 10 yr. Inline examination is normally applied to pipelines or buried piping specifically designed for this type of assessment and should be a requirement for piping systems only when the piping is specifically designed for inline examination.

(3) The predicted failure pressure level described in [para. 7.2.1](#) of ASME B31.8S shall be 1.1 times the hydrostatic pressure calculated by [para. IP-10.6.2](#). The ordinate values of the predicted failure pressure divided by the hydrostatic test pressure in ASME B31.8S, Figure 7-2.1-1 shall be used.

(4) Paragraphs 7.2.2, 7.3.2, and A3 of ASME B31.8S shall be applied to all forms of HIC.

(5) In no case shall the interval between construction and the first required reassessment of integrity exceed 5 yr. Piping systems converted from another service to hydrogen service shall be assessed at the time of conversion, and reassessment of integrity shall be done within 5 yr of conversion.

(c) *Integrity Management of Pipeline Systems.* The integrity management process for hydrogen pipelines shall follow ASME B31.8S except as shown below:

(1) Pipelines with design pressures  $\leq 15\,200$  kPa (2,200 psi) whose material of construction has a SMYS  $\leq 358$  MPa (52 ksi) should be considered Location Class 3 pipelines unless they are operating in Location Class 4 areas. Pipelines with design pressures  $> 15\,200$  kPa (2,200 psi) whose material of construction has a SMYS  $\leq 358$  MPa (52 ksi) should be considered Location Class 4 pipelines. All pipelines whose material of construction has a SMYS  $> 358$  MPa (52 ksi) shall be considered Location Class 4 pipelines.

(2) Integrity management processes should take into account the embrittlement effects of dry hydrogen gas on carbon steel pipeline materials and welds used to join pipe sections.

## GR-5.2.2 Essential Features of the Emergency Plan

(a) *Written Procedures.* Each operating company shall establish written procedures that will minimize the hazard resulting from an emergency. The procedures

shall provide instructions to operating and maintenance personnel. The procedures shall describe the following:

(1) a process for prompt and adequate handling of all calls that concern emergencies, whether they are from customers, the public, employees, or other sources, and for classifying emergencies that require response

(2) instructions for prompt and effective response to potential scenarios, including a list of personnel responsible for each action item

(3) instructions for the dissemination of information to emergency responders and the public for each scenario

(4) personnel responsible to respond to each of the scenarios listed in the emergency plans

(5) personnel responsible for updating the plan

(6) instructions for reporting and documenting the emergency

(b) *Training Program.* Each operating company shall have a program for informing, instructing, and training employees responsible for executing emergency procedures. The program shall acquaint the employee with the emergency procedures and how to promptly and effectively handle emergency situations. The program may be implemented by oral instruction, written instruction, and, in some instances, group instruction, followed by practice sessions. The program shall be established and maintained on a continuing basis with provision for updating as necessitated by revision of the written emergency procedures. Program records shall be maintained to establish what training each employee has received and the date of such training.

(c) *Liaison*

(1) Each operating company shall establish and maintain liaison with utility, fire, police, and public officials and public communications media.

(2) Emergency procedures shall be prepared in coordination with the public officials.

(3) Each operating company shall have a means of communicating with the public officials and public communications media during an emergency.

(d) *Educational Program.* An educational program shall be established to enable customers and the general public to recognize and report a hydrogen emergency to the operating company officials and emergency response agencies. The educational program called for under this section should be tailored to the operation and environment, and should be conducted in each language that is significant in the community served. Operators of distribution systems should communicate their programs to consumers and the general public in their distribution area. Operators of transmission systems should communicate their programs to residents along their pipeline right-of-way. The programs of operators in the same area should be coordinated to properly direct reports of emergencies and to avoid inconsistencies.

### GR-5.2.3 Failure Investigation

Each operating company shall establish procedures to analyze all failures and accidents to determine the cause and to minimize the possibility of a recurrence. This plan shall include a procedure to select samples of the failed facility or equipment for laboratory examination when necessary.

### GR-5.2.4 Prevention of Accidental Ignition

Smoking, open flames, and spark-producing devices shall be prohibited in and around structures or areas that are under the control of the operating company and contain hydrogen facilities (such as compressor stations, meter and regulator stations, and other hydrogen-handling equipment) where possible leakage of hydrogen constitutes a hazard of fire or explosion. Each operating company shall take steps to minimize the danger of accidental ignition of hydrogen as follows:

(a) When a hazardous amount of hydrogen will be vented into open air, each potential source of ignition shall first be removed from the area and adequate fire extinguishers shall be provided. All flashlights, lighting fixtures, extension cords, and tools shall be of a type approved for hazardous atmospheres.

(b) Signs shall be posted to warn others approaching or entering the area of the hazard.

(c) To prevent accidental ignition by electric arcing, an adequate bonding cable should be connected to each side of any piping that is to be parted or joined, and any cathodic protection rectifiers in the area shall be turned off.

(d) When cutting by torch or welding is to be performed, a thorough check shall first be made for the presence of a combustible hydrogen mixture in the area outside of the pipeline. If found, the mixture shall be eliminated before starting welding or cutting. Monitoring of air mixture should continue throughout progress of work.

(e) Should welding be anticipated on a pipeline filled with hydrogen and the safety check under (d) has been completed satisfactorily, the hydrogen pressure shall be controlled to keep a slight positive pressure in the pipeline at the welding area before starting work. Precautions should be taken to prevent a backdraft from occurring at the welding area.

(f) Before cutting by torch or welding on a line that may contain a mixture of hydrogen and air, it shall be made safe by displacing the mixture with hydrogen, air, or an inert gas. Caution must be taken when using an inert gas to provide adequate ventilation for all workers in the area.

(g) Precautions shall be taken to avoid static electricity discharges in the presence of combustible mixtures. Potential static discharge sources include

(1) flowing fluids containing liquid or solid particles, which may generate static charges, particularly in pipes or vessels during transfer.

(2) people, who can take on static charges and should ground themselves before touching or using tools on hydrogen dewars or vents. Avoiding clothing made of nylons or other synthetics, silk, or wool will lower the potential for static buildup.

### GR-5.2.5 Blasting Effects

Each operating company shall establish procedures for protection of facilities in the vicinity of blasting activities. The operating company shall

(a) locate and mark its piping or pipeline when explosives are to be detonated within distances as specified in company plans. Consideration should be given to the marking of minimum blasting distances from the piping or pipelines depending upon the type of blasting operation.

(b) determine the necessity and extent of observing or monitoring blasting activities, based upon the proximity of the blast with respect to the piping or pipelines, the size of charge, and soil conditions.

(c) conduct a leak survey following each blasting operation near its piping or pipelines.

## GR-5.3 MAINTENANCE REQUIREMENTS

The provisions of this paragraph are applicable to all piping and pipelines.

### GR-5.3.1 Corrosion Control

Procedures shall be established for evaluating the need for and effectiveness of a corrosion control program. Corrective actions commensurate with the conditions found shall be taken.

#### GR-5.3.1.1 External Corrosion of Buried Facilities

(a) *Evaluation*

(1) The records available as a result of leakage surveys and normal maintenance work shall be promptly reviewed for evidence of continuing corrosion. Whenever a buried facility is exposed during normal maintenance or construction activities, a visual examination shall be made of the coating condition and any exposed metal surface.

(2) Electrical survey methods may be used as an indication of suspected corrosive areas where surface conditions permit sufficiently accurate measurements. Such surveys are most effective in nonurban environments. Common survey methods include, but are not limited to, the following:

(-a) structure-to-soil potentials

(-b) surface potentials (cell-to-cell), known as "close interval surveys"

(-c) soil resistivity measurements

(-d) rectifier checks

(3) The continued effectiveness of a cathodic protection system shall be monitored in accordance with (c).

(b) *Corrective Measures*

(1) If continuing corrosion that, left uncontrolled, could result in a condition detrimental to public or employee safety is found, corrective measures shall be taken to mitigate further corrosion on the piping system or segment. Corrective measures shall continue to be in effect as long as required to maintain a safe operating system. Corrective measures may include any or a combination of the following:

(-a) provisions for proper and continuous operation of cathodic protection systems

(-b) application of protective coating

(-c) installation of galvanic anode(s)

(-d) application of impressed current

(-e) electrical isolation

(-f) stray current control

(-g) other effective measures as determined by sound engineering practice

(2) When experience or testing indicates the above mitigation methods will not control continuing corrosion to an acceptable level, the segment shall be reconditioned or replaced and suitably protected.

(c) *Cathodic Protection*

(1) Examinations shall be made as required to maintain continuous and effective operation of the cathodic protection system.

(2) Electrical tests shall be made periodically to determine that the piping system is protected in accordance with the applicable criteria.

(3) The type, frequency, and location of examinations and tests shall be adequate to establish with reasonable accuracy the degree of protection provided on the piping system. Frequency should be determined considering the following:

(-a) condition of pipe

(-b) method of cathodic protection

(-c) corrosiveness of the environment

(-d) probability of loss or interruption of protection

(-e) operating experience, including examinations and leak investigations

(-f) design life of the cathodic protection installation

(-g) public and employee safety

(4) Where the tests or surveys indicate that adequate protection does not exist, corrective measures shall be taken.

(5) A facility is considered to be adequately protected when it meets one or more of the following:

(-a) A negative (cathodic) voltage of at least 0.85 V is measured between the facility surface and a saturated copper-copper sulfate reference electrode contacting the electrolyte.

(-b) A minimum negative (cathodic) voltage shift of 300 mV is produced by the application of protective current.

(-c) A minimum negative (cathodic) polarization voltage shift of 100 mV is measured between the facility surface and a saturated copper-copper sulfate reference electrode contacting the electrolyte.

(-d) A facility-to-electrolyte voltage at least as negative (cathodic) as that originally established at the beginning of the Tafel segment of the  $E$ -log  $I$  curve is measured.

(-e) A net protective current from the electrolyte into the structure surface is measured by an earth current technique applied at predetermined current discharge (anodic) points of the facility.

(-f) Other means demonstrate adequate control of corrosion has been achieved.

(d) *Electrical Interference.* Adverse electrical interference from structures as determined by field tests shall be mitigated. Facilities for mitigating electrical interference shall be periodically monitored.

(e) *Casings.* Electrical isolation of cathodically protected pipelines and mains from metallic casings that are part of the underground system shall be maintained as necessary to ensure effectiveness of cathodic protection. Electrical measurements and examinations shall be made as necessary to provide timely evidence of shorts that would adversely affect cathodic protection. If there is evidence of shorts between the carrier pipe and casing that render cathodic protection of the pipeline or main ineffective, or if evidence of corrosion of the carrier pipe inside the casing is found, remedial measures shall be taken to lower the corrosion rate to an acceptable level.

**GR-5.3.1.2 External Corrosion of Above-Ground Facilities.** Facilities exposed to the atmosphere shall be periodically examined for indication of surface corrosion. Where corrosion is taking place to the extent that public or employee safety may be affected, the facility shall be reconditioned or replaced. Special consideration shall be given to surfaces near the ground line.

**GR-5.3.1.3 Internal Corrosion.** An internal corrosion control program shall include the following:

(a) The program for the detection, prevention, or mitigation of detrimental internal corrosion shall include the following:

(1) examination of leak and repair records for indication of the effects of internal corrosion

(2) visual examination of accessible internal surfaces and evaluation for internal corrosion when any part of a pipeline is removed

(3) analysis of the gas to determine the types and concentrations of any corrosive agents if evidence of internal corrosion is discovered



(4) analysis of any liquids and solids removed by pigging, draining, or cleanup, to determine the presence of corrosive materials and evidence of corrosion products

(b) Where it is determined that detrimental internal corrosion is taking place, the operating company shall take measures to correct it. One or more of the following protective or corrective measures may be used to control detrimental internal corrosion:

(1) removal of corrosive agents. If the piping system can effectively launch, pass, and receive cleaning pigs, a cleaning program may be implemented or existing pigging frequencies increased. Careful consideration shall be given when choosing the type of cleaning pig to ensure that a thorough cleaning is achieved and to prevent damage to the piping system and, if applicable, to the internal coating system.

(2) an effective chemical treatment may be applied in a manner and quantity to protect all affected portions of the piping system.

(3) addition of fittings for removal of contaminants from low spots, or positioning of the piping to reduce holdup of contaminants.

(4) application of an internal coating.

(c) Internal corrosion control measures shall be evaluated by a program that includes

(1) periodically checking any chemical additive system.

(2) evaluation of corrosion coupons and test spools at periodic intervals.

(3) periodically checking corrosion probes to help evaluate control of pipeline internal corrosion.

(4) maintaining a record of the internal condition of the pipe, of leaks and repairs from corrosion, and corrosivity of gas, liquids, or solids. The record should be used as a basis for changes in the cleaning schedule, chemical treatment program, or gas treatment facility.

(5) periodic measurements of piping component remaining wall thickness.

(d) Where examination, observation, or record analysis indicates internal corrosion is taking place to an extent that may be detrimental to public or employee safety, that portion of the system shall be repaired or reconditioned, and steps shall be taken to mitigate the internal corrosion.

### GR-5.3.2 Repair of Corroded Pipe

If the extent of corrosion has reduced the strength of a facility below that needed for the prescribed allowable operating pressure, that portion shall be repaired, reconditioned, or replaced, or the operating pressure shall be reduced, commensurate with the remaining strength of the corroded pipe. For steel pipelines, the remaining strength of corroded pipe may be determined in accordance with ASME B31G or other accepted method.

## GR-5.4 LEAKAGE SURVEYS

Each operating company shall provide for periodic leakage surveys of the facility in its operating and maintenance plan. The types of surveys selected shall be effective for determining if potentially hazardous leakage exists. The extent and frequency of the leakage surveys shall be determined by the operating company, considering the operating pressure, hoop stress level, piping age, class location, and whether the transmission line transports hydrogen without an odorant. In no case shall the interval between surveys exceed 12 months.

## GR-5.5 REPAIR PROCEDURES

The provisions in [paras. GR-5.5](#) through [GR-5.10](#) are applicable to all piping, pipelines, and mains.

(a) If at any time a defect is evident, temporary measures shall be employed immediately to protect the property and the public. If it is not feasible to make permanent repairs at the time of discovery, permanent repairs shall be made as soon as feasible as described herein. The use of a welded patch as a repair method is prohibited. If the facility is not taken out of service, the operating pressure shall be at a level that will provide safety during the repair operations.

(b) Before opening any piping to atmosphere, the system shall be purged so that the concentration of flammable gas is less than the lower flammability limit in air. Before reintroducing flammable gas into a system, reduce the concentration of air in the piping to a level that prevents a combustible mixture.

(c) A full encirclement welded split sleeve with welded ends shall have a design pressure at least equal to that required for the MAOP of the pipe being repaired. See the requirements for the applicable Part of this Code. If conditions require that the sleeve carry the full longitudinal stresses, the sleeve shall be at least equal to the design strength of the pipe being repaired. Full encirclement sleeves shall not be less than 100 mm (4 in.) long.

(d) If the defect is not a leak, this Code permits the circumferential fillet welds to be omitted in certain cases. If circumferential fillet welds are not made, the longitudinal welds may be butt welds or fillets to a side bar. The circumferential edges, which would have been sealed had the fillet weld been made, should be sealed with a coating material such as enamel or mastic, so that corrosive elements will be kept out of the area under the sleeve. Prior to the installation of a sleeve, the pipe body shall be examined by ultrasonic methods for laminations where sleeve fillet welds will be made.

## GR-5.6 INJURIOUS DENTS AND MECHANICAL DAMAGE

(a) Plain dents are injurious if they exceed a depth of 6% of the nominal pipe diameter. Plain dents of any depth are acceptable, provided strain levels associated with the deformation do not exceed 2% strain. Strain levels may be calculated in accordance with [Nonmandatory Appendix D](#) or other engineering methodology. In evaluating the depth of plain dents, the need for the segment to be able to safely pass an internal examination or cleaning device shall also be considered. Any dents that are not acceptable for this purpose should be removed prior to passing these devices through the segment, even if the dent is not injurious.

(b) All external mechanical damage with or without concurrent visible indentation of the pipe is considered injurious.

(c) Dents that contain corrosion are injurious if the corrosion is in excess of what is allowed by [para. GR-5.3.2](#).

(d) Dents that contain stress corrosion cracks or other cracks are injurious.

(e) Dents that affect ductile girth or seam welds are injurious if they exceed a depth of 2% of the nominal pipe diameter, except those evaluated and determined to be safe by an engineering analysis that considers weld quality, NDE, and operation of the facility are acceptable provided strain levels associated with the deformation do not exceed 2%.

(f) Dents of any depth that affect nonductile welds, such as acetylene girth welds or seam welds that are prone to brittle fracture, are injurious.

### GR-5.6.1 Permanent Field Repairs of Injurious Dents

(a) Injurious dents and mechanical damage shall be removed or repaired by one of the methods below, or the operating pressure shall be reduced. The reduced pressure shall not exceed 80% of the operating pressure experienced by the injurious feature at the time of discovery. Pressure reduction does not constitute a permanent repair.

(b) Removal of injurious dents or mechanical damage shall be performed by taking the facility out of service, cutting out a cylindrical piece of pipe, and replacing same with pipe of equal or greater design pressure; or by removing the defect by hot tapping, provided the entire defect is removed.

(c) Repairs of injurious dents or mechanical damage shall be performed as described below.

(1) Plain dents containing corrosion, dents containing stress corrosion cracking, and dents affecting ductile girth welds or seams may be repaired with either a full encirclement sleeve with open ends or with ends welded to the pipe.

(2) External mechanical damage, and all dents affecting acetylene girth welds or seam welds that are known to exhibit brittle fracture characteristics, may be repaired with a full encirclement steel sleeve with ends welded to the pipe.

(3) External mechanical damage, including cracks, may be repaired by grinding out the damage provided any associated indentation of the pipe does not exceed a depth of 4% of the nominal pipe diameter. Grinding is permitted to a depth of 10% of the nominal pipe wall with no limit on length. Grinding is permitted to a depth greater than 10% up to a maximum of 40% of the pipe wall, with metal removal to a length given by the following equation:

$$L = 1.12 \left\{ (Dt) \left[ \left( \frac{a/t}{1.1a/t - 0.11} \right)^2 - 1 \right] \right\}^{1/2}$$

where

$a$  = measured maximum depth of ground area, mm (in.)

$D$  = nominal outside diameter of pipe, mm (in.)

$L$  = maximum allowable longitudinal extent of ground area, mm (in.)

$t$  = nominal wall thickness of pipe, mm (in.)

Grinding shall produce a smooth contour in the pipe wall. The remaining wall thickness shall be verified. After grinding, the surface shall be examined for cracks using a nondestructive surface examination method capable of detecting cracks. If grinding within the depth and length limitations fails to completely remove the damage, the damage shall be removed or repaired in accordance with [para. GR-5.6.1](#).

(4) Dents containing stress corrosion cracking may be repaired by grinding out the cracks to a length and depth permitted in [para. GR-5.6.1](#) for corrosion in plain pipe. The wall thickness shall be checked using UT. After grinding, the surface shall be examined for cracks using a nondestructive surface examination method capable of detecting cracks. If grinding within the depth and length limitations fails to completely remove the damage, the damage shall be removed or repaired by installing a full encirclement sleeve.

### GR-5.6.2 Permanent Field Repairs of Mechanical Damage

(a) If a dent or mechanical damage is repaired with a sleeve not designed to carry maximum allowable operating line pressure, the dent shall first be filled with incompressible filler. If the sleeve is designed to carry maximum allowable operating line pressure, the incompressible filler is recommended but not required.

(b) Nonmetallic composite wrap repairs proven through reliable engineering tests and analysis are acceptable for repair of injurious dents or mechanical damage.

(c) All repairs shall pass NDE and tests as provided in para. GR-5.10.

#### **GR-5.7 PERMANENT REPAIR OF WELDS WITH DEFECTS**

(a) All circumferential butt welds found to have defects shall be repaired in accordance with the requirements of para. GR-3.4.1, provided the facility can be taken out of service. Repairs on welds may be made while the facility is in service, provided the weld is not leaking, the pressure has been reduced so that the hoop stress is below 20% of the specified minimum yield of the pipe, and grinding of the defective area can be limited so that there will remain the larger of 20% of the nominal wall and 3 mm ( $\frac{1}{8}$  in.) thickness in the pipe weld.

(b) Defective welds that cannot be repaired as described in (a) and that in the judgment of the operating company are not feasible to remove from the facility by replacement may be repaired by the installation of a full encirclement welded split sleeve using circumferential fillet welds.

(c) If a manufacturing defect is found in a double submerged arc welded seam or high frequency ERW seam, a full encirclement welded split sleeve shall be installed.

(d) If a manufacturing defect is discovered in a low frequency ERW weld seam or any seam having a factor  $E$  less than 1.0, or if hydrogen stress cracking is found in any weld zone, a full encirclement welded split sleeve designed to carry MAOP shall be installed.

(e) All repairs performed under (a) through (d) shall be tested and examined as required by para. GR-5.10.

#### **GR-5.8 PERMANENT FIELD REPAIR OF LEAKS AND NONLEAKING CORRODED AREAS**

(a) If feasible, the facility shall be taken out of service and repaired by cutting out a cylindrical piece of pipe and inserting a new piece of pipe of equal or greater design strength.

(b) If it is not feasible to take the facility out of service, repairs shall be made by the installation of a full encirclement welded split sleeve or with deposited weld metal in accordance with (e) below. If nonleaking corrosion is repaired with a full encirclement welded split sleeve, the circumferential fillet welds are optional.

(c) If the leak is due to a corrosion pit, the repair may be made by the installation of a properly designed bolt-on leak clamp.

(d) A small leak may be repaired by welding a nipple over it to vent the hydrogen while welding and then installing closure on the nipple.

(e) Small corroded areas may be repaired by filling them with deposited weld metal from low-hydrogen electrodes. When using this method, precautions shall be taken to prevent burn-through. This method of repair should not be attempted on pipe that is thought to be susceptible to brittle fracture.

(f) All repairs performed under (a), (b), and (d) above shall be tested and examined in accordance with the requirements of para. GR-5.10.

#### **GR-5.9 PERMANENT FIELD REPAIR OF HYDROGEN STRESS CRACKING IN HARD SPOTS AND STRESS CORROSION CRACKING**

(a) If feasible, the facility shall be taken out of service and repaired by cutting out a cylindrical piece of pipe and replacing same with pipe of equal or greater design strength.

(b) If it is not feasible to take the facility out of service, repairs shall be made by the installation of a full encirclement welded split sleeve. In the case of stress corrosion cracking, the fillet welds are optional. If the fillet welds are made, pressurization of the sleeve is optional. The same applies to hydrogen stress cracking in hard spots, except that a flat hard spot shall be protected with hardenable filler or by pressurization of a fillet welded sleeve.

(c) All repairs performed under (a) and (b) above shall be tested and examined as required by para. GR-5.10.

#### **GR-5.10 TESTING AND EXAMINATION OF REPAIRS**

The provisions are provided in the applicable Chapters, IP-10 for industrial piping or PL-3 for pipelines.

##### **GR-5.10.1 Testing of Replacement Pipe Sections**

When a scheduled repair to a facility is made by cutting out the damaged portion of the pipe as a cylinder and replacing it with another section of pipe, the replacement section of pipe shall be subjected to a pressure test. The replacement section of pipe shall be tested to the pressure required for a new facility installed in the same location. The tests may be made on the pipe prior to installation, provided nondestructive tests meeting the requirements of the applicable Part of this Code are made on all field girth butt welds after installation. If the replacement is made under controlled fire conditions (hydrogen in the facility), full encirclement welded split sleeves may be used to join the pipe sections instead of butt welds.

##### **GR-5.10.2 Nondestructive Examination of Repairs**

If defects are repaired by welding, the welds shall be examined in accordance with the applicable Part of this Code. All sleeve welds shall be radiographed.

## GR-5.11 VALVE MAINTENANCE

### GR-5.11.1 Piping and Transportation Pipeline Valves

Valves that are required to be operated during an emergency shall be examined periodically and partially operated at least once a year to provide safe and proper operating conditions.

(a) Routine valve maintenance procedures shall include, but not be limited to, the following:

(1) servicing in accordance with written procedures by adequately trained personnel

(2) accurate system maps for use during routine or emergency conditions

(3) valve security to prevent service interruptions, tampering, etc., as required

(4) employee training programs to familiarize personnel with the correct valve maintenance procedures

(b) Emergency valve maintenance procedures include

(1) written contingency plans to be followed during any type of emergency

(2) training personnel to anticipate all potential hazards

(3) furnishing tools and equipment as required, including auxiliary breathing equipment, to meet anticipated emergency valve servicing and/or maintenance requirements

### GR-5.11.2 Distribution System Valves

Valves, the use of which may be necessary for the safe operation of a hydrogen distribution system, shall be checked and serviced, including lubrication where necessary, at sufficiently frequent intervals to assure their satisfactory operation. Examination shall include checking of alignment to permit use of a key or wrench and clearing from the valve box or vault any debris that would interfere with or delay the operation of the valve. Valves in hydrogen service shall be checked and serviced at least annually.

### GR-5.11.3 Service Line Valves

Outside shutoff valves installed in service lines supplying places of public assembly, such as theaters, houses of worship, schools, and hospitals, shall be examined and serviced, including lubrication where necessary, at sufficiently frequent intervals to assure their satisfactory operation. The examination shall determine if the valve is accessible, if the alignment is satisfactory, and if the valve box or vault, if used, contains debris that would interfere with or delay the operation of the valve. Unsatisfactory conditions encountered shall be corrected. Valves in hydrogen service shall be checked and serviced at least annually.

### GR-5.11.4 Valve Records

A record shall be maintained for locating valves covered by [paras. GR-5.11.1](#) and [GR-5.11.2](#). This record may be maintained on operating maps, separate files, or summary sheets, and the information on this record shall be readily accessible to personnel required to respond to emergencies.

### GR-5.11.5 Prevention of Accidental Operation

Precautions shall be taken to prevent accidental operation of any valve covered by [paras. GR-5.11.1](#) and [GR-5.11.2](#). Accidental valve operation by hydrogen company personnel and the general public should be considered in taking these precautions. Some recommended actions to be taken are as follows:

(a) lock valves in aboveground settings readily accessible to the general public

(b) lock valves located in vaults, if the vault is readily accessible to the general public

(c) identify the valve by tagging, color coding, or any other means of identification

## GR-5.12 TRANSMISSION PIPELINE MAINTENANCE

The provisions of this paragraph are applicable to transmission pipelines and are in addition to those described in [para. GR-5.2](#).

### GR-5.12.1 Continuing Surveillance of Pipelines

As a means of maintaining the integrity of its pipeline system, each operating company shall establish and implement procedures for continuing surveillance of its facilities. Studies shall be initiated and action shall be taken where unusual operating and maintenance conditions occur, such as failures, leakage history, drop in flow efficiency due to internal corrosion, or substantial changes in cathodic protection requirements.

When such studies indicate the facility is in unsatisfactory condition, a planned program shall be initiated to abandon, replace, or recondition and proof test. If such a facility cannot be reconditioned or phased out, the MAOP shall be reduced commensurate with the requirements described in [Part PL](#).

### GR-5.12.2 Pipeline Patrolling

Each operating company shall maintain a periodic pipeline patrol program to observe surface conditions on and adjacent to the pipeline right-of-way, indications of leaks, construction activity other than that performed by the company, natural hazards, and any other factors affecting the safety and operation of the pipeline. Patrols shall be performed at least once each year in Locations Class 1 and 2, at least once each 6 months in Location Class 3, and at least once each 3 months in Location Class 4. Weather,



terrain, size of line, operating pressures, and other conditions will be factors in determining the need for more frequent patrol. Main highways and railroad crossings shall be examined with greater frequency and more closely than pipelines in open country.

(a) *Maintenance of Cover in Cross-Country Terrain.* If the operating company learns as a result of patrolling that the cover over the pipeline in cross-country terrain does not meet the original design, it shall determine whether the cover has been reduced to an unacceptable level. If unacceptable, the operating company shall provide additional protection by replacing cover, lowering the line, or other means.

(b) *Maintenance of Cover at Road Crossings and Drainage Ditches.* The operating company shall determine by periodic surveys if the cover over the pipeline at road crossings and drainage ditches has been reduced below the requirements of the original design. If the operating company determines that the normal cover provided at the time of pipeline construction has become unacceptably reduced due to earth removal or line movement, the operating company shall provide additional protection by providing barriers, culverts, concrete pads, casing, lowering the line, or other means.

(c) *Pipeline Leak Records.* Records shall be made covering all leaks discovered and repairs made. All pipeline breaks shall be reported in detail. These records along with leakage survey records, line patrol records, and other records relating to routine or unusual examinations shall be kept in the file of the operating company, as long as the section of line is not abandoned.

(d) *Pipeline Markers*

(1) Signs or markers shall be installed where it is considered necessary to indicate the presence of a pipeline at road, highway, railroad, and stream crossings. Additional signs and markers shall be installed along the remainder of the pipeline at locations where there is a probability of damage or interference.

(2) Signs or markers and the surrounding right-of-way shall be maintained so markers can be easily read and are not obscured.

(3) The signs or markers shall include the words "Hydrogen Pipeline," the name of the operating company, and the telephone number where the operating company can be contacted.

### GR-5.13 ABANDONING OF TRANSMISSION FACILITIES

Each operating company shall have a plan in its operating and maintenance procedures for abandoning transmission facilities. The plan shall include the following provisions:

(a) Facilities to be abandoned shall be disconnected from all sources and supplies of hydrogen, such as other pipelines, mains, crossover piping, meter stations, control lines, and other appurtenances.

(b) Facilities to be abandoned in place shall be purged of hydrogen and the ends sealed.

(c) Precautions shall be taken to ensure that a combustible mixture is not present after purging.

### GR-5.14 DECOMMISSIONING OF TRANSMISSION FACILITIES

Operators planning the decommissioning (temporary disconnect) of transmission facilities shall develop procedures for the decommissioning of facilities from service. The procedures shall include the following:

(a) Facilities to be decommissioned shall be isolated and sealed from all sources and supplies of gas such as other pipelines, mains, crossover piping, meter stations, control lines, and other appurtenances.

(b) Purging of facilities to be decommissioned with an inert material is not required. The decommissioned facility may be left containing hydrogen at a reduced pressure, but the facility should be free of detrimental corrosive contaminants.

(c) After the facilities have been decommissioned, the maintenance procedures shall continue to be applied as if the facility were still in service.

(d) The cathodic protection shall be maintained with the periodic examinations and record keeping to continue as if the facility were still in service.

(e) For stations where hydrogen remains, the Emergency Shut Down (ESD) system shall remain in service. Some modification to the ESD system may be required to allow for a low pressure ESD. The hazardous gas and fire detectors should remain in service to blow the units and piping down, if necessary.

### GR-5.15 RECOMMISSIONING OF TRANSMISSION FACILITIES

Operators planning to recommission (reactivate) transmission facilities temporarily removed from service shall develop written procedures for recommissioning facilities to service. The procedures shall include the following:

(a) Before a facility is recommissioned, all maintenance and cathodic protection records shall be reviewed to ensure that the condition and integrity of the facility has been maintained during the decommissioned period.

(b) Facilities to be recommissioned that have been decommissioned for an extended period of time shall be repressured incrementally.

(c) A leak survey shall be performed after the facility has been brought up to operating pressure. Any defects or leaks discovered shall be repaired before the facility is back in full operation.

### GR-5.16 REPOSITIONING A PIPELINE IN SERVICE

When repositioning a pipeline in service, the following are some of the factors that shall be considered:

- (a) deflection
- (b) diameter, wall thickness, and grade of pipe
- (c) pipeline pressure
- (d) type of girth welds
- (e) test and operating history
- (f) presence of defects
- (g) existing curvature
- (h) bends
- (i) valves and fittings
- (j) terrain and soil conditions
- (k) personnel safety considerations
- (l) additional stresses caused by repositioning of the pipeline

### GR-5.17 TESTING FOR INTEGRITY ASSESSMENT OF IN-SERVICE PIPELINES

The integrity of an in-service pipeline may be determined by pressure testing for strength and leaks. Comparison of new test pressures with previous test pressures will demonstrate that the integrity of the pipeline has not been reduced, if new test pressures are equal to or greater than previous test pressures. If there was no previous strength test with which to compare the current test, a minimum specified margin of safety can be established. A strength test, however, will not indicate ongoing deterioration of the pipeline that has not progressed to the point where defects fail during the strength test. Refer to [Nonmandatory Appendix C](#) for hydrostatic testing guidelines. "Integrity" is defined here as the capability of the pipeline to withstand hoop stress due to operating pressure plus a margin of safety required by this section. "In-service pipeline" is defined here as a pipeline that has been or is in service.

For piping and pipelines made from materials that may fracture at a pressure lower than the hydrotest pressure when in service, all of the following are required:

- (a) The critical crack size shall be calculated considering the possibility of both fracture and plastic collapse, using the API 579-1/ASME FFS-1 failure assessment diagram (FAD) approach (Level 2 or Level 3), or other proven fracture mechanics method.
- (b) The piping or pipeline shall be examined to verify no existing cracks are approaching the critical crack size.
- (c) The anticipated crack size based on the calculated crack growth rate will not exceed the critical size in twice the time to the next scheduled evaluation.

#### GR-5.17.1 Pressure Test Levels

When establishing test pressures for a test section, the maximum test pressure shall be determined by the operator to prevent damage to the pipeline and its components. Consideration must be given to the effect of test section elevation differences on the test pressure. Whenever test pressure will cause a hoop stress in excess of 100% of the SMYS, refer to [Nonmandatory Appendix C](#)

for guidance on yield monitoring. The minimum test pressure shall be as required by the following:

(a) To determine the integrity of an in-service pipeline by strength testing, the pipeline shall be strength tested at a pressure that will cause a hoop stress of at least 90% of the SMYS in the segment with the lowest design or rated pressure in the section tested, except as provided in (b) below.

(b) For pipelines in which SCC has been identified, defects may be mitigated by pressure testing to a pressure that will create a hoop stress of at least 100% of the SMYS at the high point elevation.

(c) Following the strength test period, a leak test should be performed. The leak test pressure should be at least 1.10 times the pipeline MAOP.

#### GR-5.17.2 Pressure Hold Period

(a) The strength test pressure shall be held for a minimum time period of  $\frac{1}{2}$  h, except for those lines with known SCC, which are to be pressure tested in accordance with (b) below.

(b) The pressure test for SCC shall be held long enough for the test pressure to stabilize, in most cases  $\frac{1}{2}$  h or less.

(c) The leak test pressure should be maintained for as long as necessary to detect and locate or evaluate any leakage of test media. Additional leak test methods may be employed if detection of leakage of the test media is not practical due to very small leaks, such as may be experienced after testing for SCC.

#### GR-5.17.3 Time Interval Between Tests

The time interval between pressure tests shall be based upon an engineering critical assessment to prevent imperfections from growing to critical sizes. That engineering critical assessment shall include the following considerations:

(a) *Risk to the Public.* The first consideration in a test or retest should be the exposure that the public could have to a failure of a given pipeline.

(b) *Stress Level of Previous Test.* Testing shows that the higher the stress level of the strength test, the smaller the remaining flaw will be. Smaller remaining flaws will result in a longer time before the flaw could be expected to grow to a critical size if not mitigated. This means that increasing the ratio of the test pressure to the operating pressure may potentially increase the retest interval.

(c) *Corrosion Rate.* The corrosion rate on a given pipeline depends upon the aggressiveness of the corrosive environment and the effectiveness of corrosion control measures.

(d) *Maintenance.* Deterioration of the pipeline is also a function of the timing and effectiveness of actions to correct such conditions as corrosion control deficiencies, external force damage, and operating conditions that increase the potential for corrosion. The effectiveness

of programs to prevent damage by excavation affects pipeline maintenance.

(e) *Other Examination Methods.* In-line examination, external electrical surveys of coating condition and cathodic protection levels, direct examination of the pipe, monitoring of internal corrosion, monitoring of gas quality, and monitoring to detect encroachment are methods that can be used to predict or confirm the presence of defects that may reduce the integrity of the pipeline.

### GR-5.18 DISTRIBUTION PIPELINE MAINTENANCE

Distribution mains shall be patrolled in areas where necessary to observe factors that may affect safe operation. The patrolling shall be considered in areas of construction activity, physical deterioration of exposed piping and supports, or any natural causes that could result in damage to the pipe. The frequency of the patrolling shall be determined by the severity of the conditions that could cause failure or leakage and the subsequent hazards to public safety.

### GR-5.19 LEAKAGE SURVEYS

Each operating company having a hydrogen distribution system shall set up, in its operating and maintenance plan, a provision for the making of periodic leakage surveys on the system.

#### GR-5.19.1 Types of Surveys

The types of surveys selected shall be effective for determining if potentially hazardous leakage exists. The following are some procedures that may be employed:

- (a) surface hydrogen detection surveys
- (b) subsurface hydrogen detector surveys (including barhole surveys)
- (c) vegetation surveys
- (d) pressure drop test
- (e) bubble leakage test
- (f) ultrasonic leakage test

#### GR-5.19.2 Frequency of Surveys

The extent and frequency of the leakage surveys shall be determined by the character of the general service area, building concentration, piping age, system condition, operating pressure, and any other known condition (such as surface faulting, subsidence, flooding, or an increase in operating pressure) that has significant potential to either start a leak or to cause leaking hydrogen to migrate to an area where it could result in a hazardous condition. Special one-time surveys should be considered following exposure of the hydrogen distribution system to unusual stresses (such as those resulting from earthquakes or blasting). The leakage survey frequencies shall be based on operating experience, sound judgment,

and knowledge of the system. Once established, frequencies shall be reviewed periodically to affirm that they are still appropriate. The frequencies of the leakage survey shall at least meet the following:

(a) Distribution systems in a principal business district should be surveyed at least annually. Such surveys shall be conducted using a combustible gas detector and shall include tests of the atmosphere, which will indicate the presence of hydrogen in utility manholes and at cracks in the pavement and sidewalks, and provide the opportunity for finding hydrogen leaks at other locations.

(b) The underground distribution system outside the areas covered by (a) above shall be surveyed as frequently as experience indicates necessary, but not less than once every 5 yr for odorized hydrogen, and not less than once every 12 months for nonodorized hydrogen.

### GR-5.20 LEAKAGE INVESTIGATION AND ACTION

#### GR-5.20.1 Leakage Classification and Repair

Prior to taking any action, any immediate hazard shall be controlled by such emergency actions as evacuation, blocking an area off, rerouting traffic, eliminating sources of ignition, ventilating, or stopping the flow of hydrogen. Leaks shall be evaluated, classified, and controlled by first determining the perimeter of the leak. When this perimeter extends to a building wall, the investigation shall continue into the building. Based on an evaluation of the location and/or magnitude of a leak, one of the following leak grades shall be assigned, thereby establishing the leak repair priority:

- (a) Grade 1 is a leak that represents an existing or probable hazard to persons or property and requires immediate repair or continuous action until the conditions are no longer hazardous.
- (b) Grade 2 is a leak that is recognized as being non-hazardous at the time of detection but requires scheduled repair based on probable future hazard.
- (c) Grade 3 is a leak that is nonhazardous at the time of detection and can be reasonably expected to remain non-hazardous.

The leak shall then be located and repaired.

#### GR-5.20.2 Investigation of Reports From Outside Sources

Any notification from an outside source (such as police or fire department, other utility, contractor, customer, or general public) reporting a leak, explosion, or fire that may involve hydrogen pipelines or other hydrogen facilities shall be investigated promptly by the operating company. If the investigation reveals a leak, the leak should be classified and action taken in accordance with the criteria in [para. GR-5.20.1](#).

### GR-5.20.3 Odor or Indications From Foreign Sources

When potentially hazardous leak indications (such as gasoline vapors, natural, sewer, or marsh gas) are found to originate from a foreign source or facility or customer-owned piping, they shall be reported to the operator of the facility and, for Grade 1 leaks, to emergency response agencies. When the company's pipeline is connected to a foreign facility (such as the customer's piping), necessary action, such as disconnecting or shutting off the flow of hydrogen to the facility, shall be taken to eliminate the potential hazard.

### GR-5.20.4 Followup Examinations

While the excavation is open, the adequacy of leak repairs shall be checked by using acceptable methods. The perimeter of the leak area shall be checked. In the case of a Grade 1 leak repair as defined in [para. GR-5.20.1](#), where there is residual hydrogen in the ground, a followup examination should be made as soon as practicable after allowing the soil atmosphere to vent and stabilize, but in no case later than 1 month following the repair. In the case of other leak repairs, the need for a followup examination should be determined by qualified personnel.

### GR-5.21 REPAIR, TESTING, AND EXAMINATION OF MAINS OPERATING AT HOOP STRESS LEVELS AT OR ABOVE 30% OF THE SMYS

Repair procedures shall be in accordance with the requirements of [para. GR-5.5](#). Testing and examination of repairs shall be in accordance with the requirements of [para. GR-5.10](#).

### GR-5.22 REQUIREMENTS FOR ABANDONING, DISCONNECTING, AND REINSTATING DISTRIBUTION FACILITIES

#### GR-5.22.1 Abandoning of Distribution Facilities

Each operating company shall have a plan for abandoning inactive facilities, such as service lines, mains, control lines, equipment, and appurtenances for which there is no planned use. The plan shall also include the following provisions:

(a) If the facilities are abandoned in place, they shall be physically disconnected from the piping system. The open ends of all abandoned facilities shall be capped, plugged, or otherwise effectively sealed. The need for purging the abandoned facility to prevent the development of a potential combustion hazard shall be considered. Any combustion hazard shall be eliminated. Abandonment shall not be completed until it has been determined that the volume of hydrogen contained within the abandoned section poses no potential hazard. Air or inert gas may be used for

purging, or the facility may be filled with water or other inert material. If air is used for purging, the operating company shall ensure that a combustible mixture is not present after purging. Consideration shall be given to any effects the abandonment may have on an active cathodic protection system.

(b) In cases where a main is abandoned, together with the service lines connected to it, insofar as service lines are concerned, only the customer's end of such service lines need be sealed as stipulated above.

(c) Service lines abandoned from the active mains should be disconnected as close to the main as practicable.

(d) All valves left in the abandoned segment should be closed. If the segment is long and there are few line valves, consideration should be given to plugging the segment at intervals.

(e) All above-grade valves, risers, and vault and valve box covers shall be removed. Vault and valve box voids shall be filled with compacted backfill material.

#### GR-5.22.2 Decommissioned Service

Whenever service to a customer is decommissioned (temporarily disconnected), one of the following shall be complied with:

(a) The valve that is closed to prevent the flow of hydrogen to the customer shall be provided with a locking device or other means designed to prevent the opening of the valve by persons other than those authorized by the operating company.

(b) A mechanical service or fitting that will prevent the flow of hydrogen shall be installed in the service line or in the meter assembly.

(c) The customer's piping shall be physically disconnected from the hydrogen supply and the open pipe ends sealed.

#### GR-5.22.3 Test Requirements for Reinstating Decommissioned Service Line

Facilities previously decommissioned shall be tested in the same manner as new facilities before being reinstated.

Service lines decommissioned because of main renewals or other planned work shall be tested from the point of disconnection to the service line valve in the same manner as new service lines before reconnecting, except

(a) when provisions to maintain continuous service are made, such as by installation of a bypass, any portion of the original service line used to maintain continuous service need not be tested, or

(b) when the service line has been designed, installed, tested, and maintained in accordance with the requirements of this Code

#### GR-5.22.4 Maintenance Records

(a) Whenever any portion or section of an existing underground distribution piping system is uncovered for operating or maintenance purposes, or for the installation of new facilities, the following information shall be recorded:

(1) the condition of the surface of bare pipe, if pitted or generally corroded

(2) the condition of the pipe surface and of the protective coating where the coating has deteriorated to the extent that the pipe is corroding underneath

(3) any damaged protective coating

(4) any repairs made

(b) Distribution piping condition records shall be analyzed periodically. Any indicated remedial action on the piping system shall be taken and recorded.

### GR-5.23 MAINTENANCE OF SPECIFIC FACILITIES

#### GR-5.23.1 Compressor Station Maintenance

(a) *Compressors and Prime Movers.* The starting, operating, and shutdown procedures for all hydrogen compressor units shall be established by the operating company. The operating company shall ensure that the approved practices are followed.

(b) *Examination and Testing of Relief Valves.* All pressure-relieving devices in compressor stations shall be examined or tested, or both, in accordance with [para. GR-5.23.3](#) and all devices except rupture disks shall be operated periodically to determine that they open at the correct set pressure. Any defective or inadequate equipment found shall be promptly repaired or replaced. All remote-control shutdown devices shall be examined and tested at least annually to determine that they function properly.

(c) *Repairs to Station Piping.* For station piping operating at hoop stress levels at or above 40% of the SMYS, repairs shall be done in accordance with [para. GR-5.5](#), and testing and examination of repairs shall be done in accordance with [para. GR-5.10](#).

(d) *Isolation of Equipment for Maintenance or Alterations.* The operating company shall establish procedures for isolation of units or sections of piping for maintenance, and for purging prior to returning units to service, and shall follow these established procedures in all cases.

(e) *Storage of Combustible Materials.* All flammable or combustible materials in quantities beyond those required for everyday use or other than those normally used in compressor buildings shall be stored in a separate structure, built of noncombustible material, located away from the compressor building. All aboveground oil or gasoline storage tanks shall be protected in accordance with NFPA 30.

#### GR-5.23.2 Procedures for Maintaining Pipe-Type and Bottle-Type Holders in Safe Operating Condition

(a) Each operating company having a pipe-type or bottle-type holder shall prepare, and place in its files, a plan for routine examination and testing of the facilities that has the following provisions:

(1) Procedures shall be followed to enable the detection of external corrosion before the strength of the container has been impaired.

(2) Periodic sampling and testing of hydrogen in storage shall be made to determine that the level of contaminants contained in the stored hydrogen is below that which might cause internal corrosion or interfere with the safe operations of the storage plant.

(3) The pressure-control and pressure-limiting equipment shall be examined and tested periodically to see if it is in a safe operating condition and has adequate capacity.

(b) Each operating company shall follow the plan described in (a) above and keep records that detail the examination and testing work done and the conditions found.

(c) All unsatisfactory conditions found shall be promptly corrected.

#### GR-5.23.3 Maintenance of Pressure-Limiting and Pressure-Regulating Stations

(a) *Condition and Adequacy.* Pressure-limiting stations, relief devices, and other pressure-regulating stations and equipment shall be periodically examined and tested to determine that they

(1) are in good mechanical condition. Visual examination shall be made to determine that equipment is properly installed and protected from dirt, liquids, or other conditions that might prevent proper operation. When part of the installation, the following shall be included in the examination:

(-a) station piping supports, pits, and vaults for general condition and indications of ground settlement. See [para. GR-5.23.4](#) for vault maintenance.

(-b) station doors and gates and pit vault covers to ensure that they are functioning properly and that access is adequate and free from obstructions.

(-c) ventilating equipment installed in station buildings or vaults, for proper operation and for evidence of accumulation of water, ice, snow, or other obstructions.

(-d) control, sensing, and supply lines for conditions that could result in a failure.

(-e) all locking devices for proper operation.

(-f) station schematics for correctness.

(2) have needed capacity and reliability for the service in which they are employed and are set to function at the correct pressure.



(-a) At least once each calendar year, an operational check shall be made. If acceptable operation is not obtained during the operational check, the cause of the malfunction shall be determined and the components shall be adjusted, repaired, or replaced as required. After repair, the component shall again be checked for proper operation.

(-b) Any time a change is made that affects the needed capacity, a review shall be made to ensure that the combined capacity of the relief devices on each piping system is adequate to limit the pressure at all times to values prescribed by the engineering design. This review should be based on the operating conditions that create the maximum probable requirement for relief capacity in each case, even though such operating conditions actually occur infrequently or for only short periods of time, or both. If it is determined that the relieving equipment is of insufficient capacity, steps shall be taken to install new or additional equipment to provide adequate capacity.

(b) *Repairs to Station Piping.* For station piping operating at hoop stress levels at or above 40% of the SMYS, repairs shall be done in accordance with [para. GR-5.5](#), and testing and examination of repairs shall be done in accordance with [para. GR-5.10](#).

(c) *Abnormal Conditions.* Whenever abnormal conditions are imposed on pressure or flow control devices, the incident shall be investigated and a determination made as to the need for examination or repairs, or both. Abnormal conditions may include regulator bodies that are subjected to erosive service conditions or contaminants from upstream construction and hydrostatic testing.

(d) *Stop Valves*

(1) An examination of stop valves that includes an operational check shall be made to ensure that the valves will operate and are correctly positioned. (Caution shall be used to avoid any undesirable effect on pressure during operational checks.) The following shall be included in the examination:

- (-a) station inlet, outlet, and bypass valves
- (-b) relief device isolating valves
- (-c) control, sensing, and supply line valves

(2) The examination procedure shall include the following:

(-a) a check for proper position of all valves. Special attention shall be given to regulator station bypass valves, relief device isolating valves, and valves in control, sensing, and supply lines.

(-b) restoration of all locking and security devices to proper position.

(3) Examination frequency shall not be less than annually.

(e) *District Pressure*

(1) Every distribution system supplied by more than one district pressure-regulating station shall be equipped with devices that record the hydrogen pressure in the district.

(2) On distribution systems supplied by a single district pressure-regulating station, the operating company shall determine the necessity of installing such devices in the district, considering the number of customers supplied, the operating pressures, and the capacity of the installation.

(3) If there are indications of abnormal high or low pressure, the regulator and the auxiliary equipment shall be examined, and the necessary measures shall be employed to rectify any unsatisfactory operating conditions. Periodic examinations of single district pressure-regulating stations not equipped with devices that record hydrogen pressure shall be made to determine that the pressure-regulating equipment is functioning properly.

#### GR-5.23.4 Vault Maintenance

Each vault housing a pressure-limiting, pressure-relief, or pressure-regulating station shall be examined to determine its condition each time the equipment is examined and tested in accordance with [para. GR-5.23.3](#). For any vault which personnel enter, the atmosphere shall be tested for combustible gas. If the atmosphere is hazardous, the cause shall be determined. The vault shall be examined for adequate ventilation. The condition of the vault covers shall be carefully examined for hazards. Unsatisfactory conditions disclosed shall be corrected. No welding may be done if a combustible gas mixture is present. Maintenance work performed in the vault shall be in accordance with procedures developed per [para. GR-5.23.3](#), with particular consideration given to the monitoring of the atmosphere and safety protection for personnel in the vault.

## Chapter GR-6

# Quality System Program for Hydrogen Piping and Pipeline Systems

(23)

### GR-6.1 QUALITY SYSTEM PROGRAM FOR INDUSTRIAL PIPING

Design, construction, inspection, examination, testing, manufacture, fabrication, and erection of piping in accordance with this Code shall be performed under a Quality System Program following the principles of an appropriate standard such as ASME QSP-1 or the ISO 9000<sup>1</sup> series. The details describing the quality system shall be documented and shall be available upon request. A determination of the need for registration or certification or both of the quality system program shall be the responsibility of the owner.

### GR-6.2 QUALITY SYSTEM PROGRAM FOR PIPELINES

Quality assurance for design, fabrication, assembly, erection, inspection, examination, testing, installation, operation, and maintenance of pipelines shall follow the requirements of ASME B31.8, section 806. Personnel involved in operation, maintenance, and construction activities shall be trained and qualified in accordance with ASME B31.8, section 807.

---

<sup>1</sup>The series is also available from the American National Standards Institute (ANSI) and the American Society for Quality (ASQ) as American National Standards that are identified by similar "9000" numbers, sometimes with the prefix "Q" replacing the prefix "ISO." [Mandatory Appendix II](#) lists the standards from the series that are applicable to ASME B31.12.

# PART IP

## INDUSTRIAL PIPING

---

### Chapter IP-1

#### Scope and Responsibilities

##### IP-1.1 SCOPE

Rules for this Part have been developed for hydrogen service included in petroleum refineries, refueling stations, chemical plants, power generation plants, semiconductor plants, cryogenic plants, hydrogen fuel appliances, and related facilities.

##### IP-1.1.1 Content and Coverage

This Part includes requirements for materials and components, design, fabrication, assembly, erection, inspection, examination, testing, operation, and maintenance of piping, and applies to piping for liquid and gaseous hydrogen and joints connecting piping to equipment.

##### (23) IP-1.1.2 Exclusions

(a) This Part excludes tubes, tube headers, crossovers, and manifolds of fired heaters, which are internal to the heater enclosure, and pressure vessels, heat exchangers, pumps, compressors, and other fluid handling or processing equipment, including internal piping and connections for external piping.

(b) Elevated temperature fluid service as defined in ASME B31.3 is excluded. See ASME B31.3, Chapters I through VI for applicable requirements.

(c) High pressure fluid service as defined in ASME B31.3 is excluded. See ASME B31.3, Chapter IX for applicable requirements. See [Nonmandatory Appendix A, para. A-2.13](#).

##### IP-1.2 RESPONSIBILITIES

##### IP-1.2.1 Owner

[Paragraph GR-1.2](#) applies.

##### IP-1.2.2 Designer

[Paragraph GR-1.2](#) applies.

##### IP-1.2.3 Construction Organization

[Paragraph GR-1.2](#) applies.

##### IP-1.2.4 Owner's Inspector

[Paragraph GR-1.2](#) applies.

##### IP-1.3 INTENT

[Paragraph GR-1.3](#) applies.

##### IP-1.4 DETERMINING CODE REQUIREMENTS

Code requirements for design and construction include service requirements, which affect selection and application of materials, components, and joints. Service requirements include prohibitions, limitations, and conditions, such as temperature or pressure limits. Code requirements for a piping system shall be the most restrictive of those that apply to any of its elements.



## Chapter IP-2

# Design Conditions and Criteria

### IP-2.1 DESIGN CONDITIONS

This Chapter provides the qualifications of the designer, defines the temperatures, pressures, and forces applicable to the design of piping, and states the consideration that shall be given to various effects and their consequent loadings. In addition, the selection of pressures, temperatures, forces, and other conditions may be influenced by unusual conditions. (For cautionary considerations, see [Nonmandatory Appendix A](#).)

#### IP-2.1.1 Qualifications of the Designer

The designer is the person(s) in charge of the engineering design of a piping system and shall be experienced in the use of ASME B31 piping codes. The qualifications and experience required of the designer will depend on the complexity and criticality of the system, and the nature of the individual's experience. The owner's approval is required if the individual does not meet at least one of the following criteria:

(a) completion of an accredited engineering degree, requiring the equivalent of 4 yr or more of study, plus a minimum of 5 yr of experience in the design of related pressure piping.

(b) professional engineering registration, recognized by the local jurisdiction, and experience in the design of related pressure piping.

(c) completion of an accredited engineering technician or associate degree, requiring the equivalent of at least 2 yr of study, plus a minimum of 10 yr of experience in the design of related pressure piping.

(d) 15 yr of experience in the design of related pressure piping. Experience in the design of related pressure piping is satisfied by piping design experience that includes design calculations for pressure, sustained loads, occasional loads, and piping flexibility.

#### IP-2.1.2 Design Pressure

(a) The design pressure of each component in a piping system shall be not less than the pressure at the most severe condition of coincident internal or external pressure and temperature (minimum or maximum) expected during service.

(b) The most severe condition is that which results in the greatest required component thickness and the highest component rating.

(c) When more than one set of pressure–temperature conditions exist for a piping system, the conditions governing the rating of components conforming to listed standards may differ from the conditions governing the rating of components designed in accordance with [Chapter IP-3](#).

(d) When a pipe is separated into individualized pressure-containing chambers (including jacketed piping, blanks, etc.), the partition wall shall be designed on the basis of the most severe coincident temperature (minimum or maximum) and differential pressure between the adjoining chambers expected during service.

#### IP-2.1.3 Required Pressure Containment or Relief

(a) Provision shall be made to safely contain or relieve (see [para. IP-7.2.3](#)) any expected pressure to which the piping may be subjected. Piping not protected by a pressure-relieving device, or that can be isolated from a pressure-relieving device, shall be designed for at least the highest pressure that can be developed.

(b) Sources of pressure to be considered include ambient influences, pressure oscillations and surges, improper operation, reaction of hydrogen with other elements or compounds, external fire, static head, and failure of control devices.

#### IP-2.1.4 Design Temperature

The design temperature of each component in a piping system is the temperature at which, under the coincident pressure, the greatest thickness or highest component rating is required in accordance with [para. IP-2.1.2](#). (To satisfy the requirements of [para IP-2.1.2](#), different components in the same piping system may have different design temperatures.) In establishing design temperatures, consider at least the fluid temperatures, ambient temperatures, solar radiation, heating or cooling medium temperatures, and the applicable provisions of [para. IP-2.1.6](#).

#### IP-2.1.5 Design Minimum Temperature

The design minimum temperature is the lowest component temperature expected in service. This temperature may establish special design requirements and material qualification requirements. See also [paras. IP-2.1.7\(c\)](#) and [GR-2.1.2\(b\)](#).

### IP-2.1.6 Component Design Temperature

The component design temperature shall be the fluid temperature unless calculations, tests, or service experience based on measurements support the use of another temperature.

### IP-2.1.7 Ambient Effects

(a) *Fluid Expansion Effects.* Provision shall be made in the design either to withstand or to relieve increased pressure caused by the heating of static fluid in a piping component.

(b) *Atmospheric Icing.* Where the design minimum temperature of a piping system is colder than 0°C (32°F), the possibility of moisture condensation and buildup of ice shall be considered, and provisions made in the design to avoid resultant malfunctions. This applies to surfaces of moving parts of shutoff valves, control valves, pressure relief devices including discharge piping, and other components.

(c) *Low Ambient Temperature.* Consideration shall be given to low ambient temperature conditions for displacement stress analysis.

### IP-2.1.8 Dynamic Effects

(a) *Impact.* Impact forces caused by external or internal conditions (including changes in flow rate, hydraulic shock, liquid or solid slugging, and flashing) shall be taken into account in the design of piping.

(b) *Wind.* The effect of wind loading shall be taken into account in the design of exposed piping. The method of analysis may be as described in ASCE 7, Minimum Design Loads for Buildings and Other Structures, or the applicable model building code.

(c) *Earthquake.* The effect of earthquake loading shall be taken into account in the design of piping. The method of analysis may be as described in ASME B31E or ASCE 7.

(d) *Vibration.* Piping shall be designed, arranged, and supported so as to eliminate harmful effects of vibration, which may arise from such sources as impact, pressure pulsation, turbulent flow vortices, resonance in compressors, and wind.

(e) *Discharge Reactions.* Piping shall be designed, arranged, and supported so as to withstand reaction forces due to letdown or discharge of fluids.

(f) *Weight Effects.* The following weight effects, combined with loads and forces from other causes, shall be taken into account in the design of piping:

(1) *Live Loads.* These loads include the weight of the medium transported or the medium used for test. Snow and ice loads due to both environmental and operating conditions shall be considered.

(2) *Dead Loads.* These loads consist of the weight of piping components, insulation, and other superimposed permanent loads supported by the piping.

(g) *Thermal Expansion and Contraction Effects.* The following thermal effects, combined with loads and forces from other causes, shall be taken into account in the design of piping:

(1) *Thermal Loads Due to Restraints.* These loads consist of thrusts and moments, which arise when free thermal expansion and contraction of the piping are prevented by restraints or anchors.

(2) *Loads Due to Temperature Gradients.* These loads arise from stresses in pipe walls resulting from large rapid temperature changes or from unequal temperature distribution, as may result from a high heat flux through a comparatively thick pipe or stratified two-phase flow causing bowing of the line.

(3) *Loads Due to Differences in Expansion Characteristics.* These loads result from differences in thermal expansion where materials with different thermal expansion coefficients are combined, as in bimetallic, lined, jacketed, or metallic-nonmetallic piping.

(h) *Effects of Support, Anchor, and Terminal Movements.* The effects of movements of piping supports, anchors, and connected equipment shall be taken into account in the design of piping. These movements may result from the flexibility and/or thermal expansion of equipment, supports, or anchors, and from settlement, tidal movements, seismic, or wind sway. Pipe supports for thin wall vacuum jacketed pipe should be located at points on the jacket with doubler plates or load-spreading saddles.

(i) *Reduced Ductility Effects.* The harmful effects of reduced ductility shall be taken into account in the design of piping. The effects may, for example, result from HE, welding, heat treatment, forming, bending, low operating temperatures, or ambient temperatures.

(j) *Cyclic Effects.* Fatigue due to pressure cycling, thermal cycling, and other cyclic loadings along with local stress levels that may be increased by the presence of discontinuities, internal misalignment, and excess root penetration shall be considered in the design of piping. Particular care must be exercised in the design of piping in dry hydrogen gas service. See [Nonmandatory Appendix A](#).

(k) *Air Condensation Effects.* At operating temperatures colder than -191°C (-312°F) in ambient air, condensation and oxygen enrichment occur. These shall be considered in selecting materials, including insulation, and adequate shielding and/or disposal shall be provided.

## IP-2.2 DESIGN CRITERIA

This paragraph states pressure-temperature ratings, stress criteria, design allowances, and minimum design values, together with permissible variations of these factors, to be applied to the design of piping.

### IP-2.2.1 Pressure–Temperature Design Criteria

The material performance factor,  $M_f$ , shall be considered when determining design criteria. Refer to [Mandatory Appendix IX, Tables IX-5B and IX-5C](#).

### IP-2.2.2 Listed Components Having Established Ratings

Except as limited elsewhere in this Code, pressure–temperature ratings contained in standards for piping components listed in [Table IP-8.1.1-1](#) are acceptable for design pressures and temperatures in accordance with this Code. The provisions of this Code may be used to extend the pressure–temperature ratings of a component beyond the ratings of the listed standard, provided the owner approves.

### IP-2.2.3 Listed Components Not Having Specific Ratings

Some of the standards for components in [Table IP-8.1.1-1](#) (e.g., ASME B16.9 and ASME B16.11) state that pressure–temperature ratings are based on straight seamless pipe. Except as limited in the standard or elsewhere in this Code, such a component, made of a material having the same allowable stress as the pipe, shall be rated using not more than 87.5% of the nominal thickness of seamless pipe corresponding to the schedule, weight, or pressure class of the fitting, less all allowances applied to the pipe (e.g., thread depth and/or corrosion allowance).

### IP-2.2.4 Unlisted Components

(a) Components not listed in [Table IP-8.1.1-1](#), but which conform to a published specification or standard, may be used within the following limitations:

(1) The designer shall be satisfied that composition, mechanical properties, method of manufacture, and quality control are comparable to the corresponding characteristics of listed components.

(2) Pressure design shall be verified in accordance with [Chapter IP-3](#).

(b) Other unlisted components shall be qualified for pressure design as required by [para. IP-3.8.2](#).

### IP-2.2.5 Ratings at Junction of Different Services

When two services that operate at different pressure–temperature conditions are connected, the valve segregating the two services shall be rated for the more severe service condition. If the valve will operate at a different temperature due to its remoteness from a header or piece of equipment, this valve (and any mating flanges) may be selected on the basis of the different temperature, provided it can withstand the required pressure tests on each side of the valve. For piping on either side of the valve, however, each

system shall be designed for the conditions of the service to which it is connected.

### IP-2.2.6 Allowable Stresses and Other Stress Limits

The allowable stresses defined in (a), (b), and (c) below shall be used in design calculations unless modified by other provisions of this Code. The material performance factor,  $M_f$ , as shown in [Mandatory Appendix IX, Tables IX-5B and IX-5C](#), shall be used in [Chapter IP-3](#).

(a) *Tension*. Basic allowable stresses in tension for metals and design stresses,  $S$ , for bolting materials, listed in [Mandatory Appendix IX, Tables IX-1 and IX-4](#), respectively, are determined in accordance with [para. IP-2.2.7](#). In equations elsewhere in the Code where the product  $SE$  appears, the value  $S$  is multiplied by one of the following quality factors:<sup>1</sup>

(1) casting quality factor,  $E_c$ , as defined in [para. IP-2.2.8](#) and tabulated for various material specifications in [Mandatory Appendix IX, Table IX-2](#), and for various levels of supplementary examination in [Table IP-2.2.8-1](#)

(2) longitudinal weld joint factor,  $E_j$ , as defined in [para. IP-2.2.9](#) and tabulated for various material specifications and classes in [Mandatory Appendix IX, Table IX-3A](#), and for various types of joints and supplementary examinations in [Table IP-2.2.9-1](#)

The stress values in [Mandatory Appendix IX, Tables IX-1 and IX-4](#) are grouped by materials and product forms, and are for stated temperatures up to the limit provided in [para. GR-2.1.2\(a\)](#). Straight-line interpolation between temperatures is permissible. The temperature intended is the design temperature (see [para. IP-2.1.4](#)). Material performance factors located in [Mandatory Appendix IX, Tables IX-5A through IX-5C](#) are grouped by material type, material tensile or yield strength, and maximum system design pressure. Straight-line interpolation is permissible.

(b) *Shear and Bearing*. Allowable stresses in shear shall be 0.80 times the basic allowable stress in tension tabulated in [Mandatory Appendix IX, Table IX-1A or Table IX-4](#). Allowable stress in bearing shall be 1.60 times the allowable stress in tension. Shear allowable stress must be multiplied by the appropriate material performance factor,  $M_f$ .

(c) *Compression*. Allowable stresses in compression shall be no greater than the basic allowable stresses in tension as tabulated in [Mandatory Appendix IX](#). Consideration shall be given to structural stability.

<sup>1</sup> If a component is made of castings joined by longitudinal welds, both a casting and a weld joint quality factor shall be applied. The equivalent quality factor,  $E$ , is the product of  $E_c$  (see [Mandatory Appendix IX, Table IX-2](#)) and  $E_j$  (see [Mandatory Appendix IX, Table IX-3A](#)).

### IP-2.2.7 Bases for Design Stresses<sup>2</sup>

The bases for establishing design stress values for bolting materials and allowable stress values for other metallic materials in this Code are as follows:

(a) *Bolting Materials.* Design stress values at temperature for bolting materials shall not exceed the lowest of the following:

(1) except as provided in (3) below, the lower of one-fourth of specified minimum tensile strength at room temperature,  $S_T$ , and one-fourth of tensile strength at temperature

(2) except as provided in (3) below, the lower of two-thirds of SMYS at room temperature,  $S_Y$ , and two-thirds of yield strength at temperature

(3) at temperatures below the creep range, for bolting materials whose strength has been enhanced by heat treatment or strain hardening, the lower of one-fifth of  $S_T$  and one-fourth of  $S_Y$  (unless these values are lower than corresponding values for annealed material, in which case the annealed values shall be used)

(4) two-thirds of the yield strength at temperature [see (d) below]

(5) 100% of the average stress for a creep rate of 0.01% per 1000 h

(6) 67% of the average stress for rupture at the end of 100 000 h

(7) 80% of minimum stress for rupture at the end of 100 000 h

(b) *Other Materials.* Basic allowable stress values at temperature for materials other than bolting materials shall not exceed the following:

(1) the lower of one-third of  $S_T$  and one-third of tensile strength at temperature

(2) except as provided in (3) below, the lower of two-thirds of  $S_Y$  and two-thirds of yield strength at temperature

(3) for austenitic stainless steels and nickel alloys having similar stress-strain behavior, the lower of two-thirds of  $S_Y$  and 90% of yield strength at temperature [see (c) below]

(4) 100% of the average stress for a creep rate of 0.01% per 1000 h

(5) 67% of the average stress for rupture at the end of 100 000 h

(6) 80% of the minimum stress for rupture at the end of 100 000 h

(7) for structural grade materials, the basic allowable stress shall be 0.92 times the lowest value determined in (1) through (6) above

(8) in the application of these criteria, the yield strength at room temperature is considered to be  $S_Y R_Y$  and the tensile strength at room temperature is considered to be  $1.1 S_T R_T$

(c) *Application Limits.* Application of stress values determined in accordance with (b)(3) above is not recommended for flanged joints and other components in which slight deformation can cause leakage or malfunction. [These values are shown in italics or boldface in [Mandatory Appendix IX, Table IX-1A](#), as explained in [Note \(7\)](#) of the table.] Instead, either 75% of the stress value in [Mandatory Appendix IX, Table IX-1A](#) or two-thirds of the yield strength at temperature listed in ASME BPVC, Section II, Part D, Table Y-1 should be used.

(d) *Unlisted Materials.* For a material that conforms to [para. GR-2.1.1\(b\)](#), the tensile (yield) strength at temperature shall be derived by multiplying the average expected tensile (yield) strength at temperature by the ratio of  $S_T$  ( $S_Y$ ) divided by the average expected tensile (yield) strength at room temperature.

### IP-2.2.8 Casting Quality Factor, $E_C$

(a) The casting quality factors,  $E_C$ , defined herein shall be used for cast components not having pressure-temperature ratings established by standards listed in [Table IP-8.1.1-1](#).

(b) *Basic Quality Factors.* Static castings that conform to the material specification and have been visually examined as required by MSS SP-55, Quality Standard for Steel Castings for Valves, Flanges and Fittings and Other Piping Components — Visual Method, are assigned a basic casting quality factor,  $E_C$ , of 0.80. Centrifugal castings that meet specification requirements only for chemical analysis; tensile, hydrostatic, and flattening tests; and visual examination are assigned a basic casting quality factor of 0.80. Basic casting quality factors are tabulated for listed specifications in [Mandatory Appendix IX, Table IX-2](#).

(c) *Increased Quality Factors.* Casting quality factors may be increased when supplementary examinations are performed on each casting. [Table IP-2.2.8-1](#) states the increased casting quality factors,  $E_C$ , that may be used for various combinations of supplementary examination. [Table IP-2.2.8-2](#) states the acceptance criteria for the examination methods specified in the Notes to [Table IP-2.2.8-1](#). Quality factors higher than those shown in [Table IP-2.2.8-1](#) do not result from combining tests (2)(a) and (2)(b), or (3)(a) and (3)(b). In no case shall the quality factor exceed 1.00. Several of the specifications in [Mandatory Appendix IX](#) require machining of all surfaces and/or one or more of these supplementary

<sup>2</sup> These bases are the same as those given in ASME BPVC, Section II, Part D. Stress values in [Mandatory Appendix IX](#) at temperatures below the creep range generally are the same as those listed in Section II, Part D, Tables 5A and 5B, and in Table 3 for bolting, corresponding to those bases. They have been adjusted as necessary to exclude casting quality factors and longitudinal weld joint quality factors. Stress values at temperatures in the creep range generally are the same as those in Section II, Part D, Tables 1A and 1B, corresponding to the bases for Section VIII, Division 1. Stress values for temperatures above those for which values are listed in the BPVC, and for materials not listed in the BPVC, are based on those listed in Appendix A of the 1966 Edition of ASA B31.3. Such values will be revised when reliable mechanical property data for elevated temperatures and/or for additional materials become available to the Committee.



**Table IP-2.2.8-1**  
**Increased Casting Quality Factors,  $E_c$**

| Supplementary Examination<br>in Accordance With Note(s) | Factor,<br>$E_c$ |
|---|------------------|
| (1)   | 0.85             |
| (2)(a) or (2)(b)  | 0.85             |
| (3)(a) or (3)(b)  | 0.95             |
| (1) and (2)(a) or (2)(b)                                | 0.90             |
| (1) and (3)(a) or (3)(b)                                | 1.00             |
| (2)(a) or (2)(b) and (3)(a) or (3)(b)                   | 1.00             |

GENERAL NOTE: Titles of standards referenced in this table's Notes are as follows:

|              |  |
|--------------|--|
| ASME B46.1   | Surface Texture (Surface Roughness, Waviness and Lay)  |
| ASTM E114    | Practice for Ultrasonic Pulse-Echo Straight-Beam Testing by the Contact Method   |
| ASTM E125    | Reference Photographs for Magnetic Particle Indications on Ferrous Castings  |
| ASTM E142-92 | Method for Controlling Quality of Radiographic Testing   |
| ASTM E165    | Practice for Liquid Penetrant Examination for General Industry   |
| ASTM E709-80 | Practice for Magnetic Particle Examination   |
| MSS SP-53    | Quality Standard for Steel Castings and Forgings for Valves, Flanges and Fittings and Other Piping Components — Magnetic Particle Examination Method |

NOTES:

- (1) Machine all surfaces to a finish of  $6.3 \mu\text{m } R_a$  (250  $\mu\text{in. } R_a$  per ASME B46.1), thus increasing the effectiveness of surface examination.
- (2)
  - (a) Examine all surfaces of each casting (magnetic material only) by the magnetic particle method in accordance with ASTM E709. Judge acceptability in accordance with MSS SP-53, using reference photos in ASTM E125.
  - (b) Examine all surfaces of each casting by the liquid penetrant method, in accordance with ASTM E165. Judge acceptability of flaws and weld repairs in accordance with Table 1 of MSS SP-53, using ASTM E125 as a reference for surface flaws.
- (3)
  - (a) Fully examine each casting ultrasonically in accordance with ASTM E114, accepting a casting only if there is no evidence of depth of defects in excess of 5% of wall thickness.
  - (b) Fully radiograph each casting in accordance with ASTM E142. Judge in accordance with the stated acceptance levels in Table IP-2.2.8-2.

examinations. In such cases, the appropriate increased quality factor is shown in Table IP-2.2.8-1.

### IP-2.2.9 Weld Joint Quality Factors, $E_j$

(a) *Basic Quality Factors.* The weld joint quality factors,  $E_j$ , tabulated in Mandatory Appendix IX, Table IX-3A are basic factors for longitudinal welded joints for pressure-containing components as shown in Table IP-2.2.9-1.

(b) *Increased Quality Factors.* Table IP-2.2.9-1 also indicates higher joint quality factors that may be substituted for those in Mandatory Appendix IX, Table IX-3A for certain kinds of welds if additional examination is performed beyond that required by the product specification.

### IP-2.2.10 Limits of Calculated Stresses Due to Sustained Loads and Displacement Strains (23)

(a) *Internal Pressure Stresses.* Stresses due to internal pressure shall be considered safe when the wall thickness of the piping component, including any reinforcement, meets the requirements of para. IP-3.2.

(b) *External Pressure Stresses.* Stresses due to external pressure shall be considered safe when the wall thickness of the piping component, and its means of stiffening, meet the requirements of para. IP-3.2.

(c) *Stresses Due to Sustained Loads,  $S_L$ .* The sum of the longitudinal stresses,  $S_L$ , in any component in a piping system, due to sustained loads such as pressure and weight, shall not exceed the product  $S_h M_f$ .  $S_h$  is the basic allowable stress provided in Mandatory Appendix IX, Table IX-1A at the metal temperature for the operating condition being considered.  $M_f$  is as shown in Mandatory Appendix IX, Tables IX-5B and IX-5C.

(d) *Allowable Displacement Stress Range,  $S_A$ .* The computed displacement stress range,  $S_E$ , in a piping system (see Chapter IP-6) shall not exceed the allowable displacement stress range,  $S_A$ , calculated in accordance with ASME B31.3, para. 302.3.5(d), except that the equivalent number of full displacement cycles,  $N$ , shall be increased by a factor of 10 for carbon and low alloy steels and other materials that are susceptible to HE when the system design temperature is within the HE range [up to 150°C (300°F)].

### IP-2.2.11 Limits of Calculated Stresses Due to Occasional Loads

(a) *Operation.* The sum of the longitudinal stresses,  $S_L$ , due to sustained loads, such as pressure and weight, and of the stresses produced by occasional loads, such as wind or earthquake, may be as much as 1.33 times the basic allowable stress given in Mandatory Appendix IX times the material performance factor,  $M_f$ .

**Table IP-2.2.8-2**  
**Acceptance Levels for Castings**

| Material Examined Thickness, $T$                       | Applicable Standard | Acceptance Level (or Class) | Acceptable Discontinuities     |
|--|---------------------|-----------------------------|--------------------------------|
| Steel $T \leq 25$ mm (1 in.)                           | ASTM E446-98        | 1                           | Types A, B, C                  |
| Steel $T > 25$ mm, $\leq 51$ mm (2 in.)                | ASTM E446-98        | 2                           | Types A, B, C                  |
| Steel $T > 51$ mm, $\leq 114$ mm ( $4\frac{1}{2}$ in.) | ASTM E186-98        | 2                           | Categories A, B, C             |
| Steel $T > 114$ mm, $\leq 305$ mm (12 in.)             | ASTM E280           | 2                           | Categories A, B, C             |
| Aluminum and magnesium                                 | ASTM E155           | ...                         | Shown in reference radiographs |
| Copper, Ni-Cu  | ASTM E272           | 2                           | Codes A, Ba, Bb                |
| Bronze   | ASTM E310           | 2                           | Codes A and B                  |

GENERAL NOTE: Titles of ASTM standards referenced in this table are as follows:

|         |   |
|---------|---|
| E155    | Reference Radiographs for Inspection of Aluminum and Magnesium Castings                           |
| E186-98 | Reference Radiographs for Heavy-Walled (2 to $4\frac{1}{2}$ -in. [51 to 114-mm]) Steel Castings   |
| E272    | Reference Radiographs for High-Strength Copper-Base and Nickel-Copper Castings                    |
| E280    | Reference Radiographs for Heavy-Walled ( $4\frac{1}{2}$ to 12-in. [114 to 305-mm]) Steel Castings |
| E310    | Reference Radiographs for Tin Bronze Castings   |
| E446-98 | Reference Radiographs for Steel Castings Up to 2 in. (51 mm) in Thickness                         |

The allowable stress for occasional loads of short duration, such as surge, extreme wind, or earthquake, may be taken as the strength reduction factor times 90% of the yield strength at temperature times  $M_f$  for materials with ductile behavior. This yield strength shall be as listed in ASME BPVC, Section II, Part D, Table Y-1 (ensure materials are suitable for hydrogen service; see API 941), or determined in accordance with [para. IP-2.2.7\(d\)](#). The strength reduction factor represents the reduction in yield strength with long-term exposure of the material to elevated temperatures and, in the absence of more applicable data, shall be taken as 1.0 for austenitic stainless steel and 0.8 for other materials. For castings, the basic allowable stress shall be multiplied by the casting quality factor,  $E_c$ . Where the allowable stress value exceeds two-thirds of yield strength at temperature, the allowable stress value must be reduced as specified in [para. IP-2.2.7\(c\)](#). Wind and earthquake forces need not be considered as acting concurrently. At temperatures warmer than  $427^\circ\text{C}$  ( $800^\circ\text{F}$ ), use  $1.33S_hM_f$ .

(b) *Test.* Stresses due to test conditions are not subject to the limitations in [para. IP-2.2.6](#). It is not necessary to consider other occasional loads, such as wind and earthquake, as occurring concurrently with test loads.





### IP-2.2.12 Allowances

In determining the minimum required thickness of a piping component, allowances shall be included for corrosion, erosion, and thread depth or groove depth.

### IP-2.2.13 Mechanical Strength

When necessary, the thickness shall be increased to prevent overstress, damage, collapse, or buckling due to superimposed loads from supports, ice formation, backfill, transportation, handling, or other causes. Where increasing the thickness would excessively increase local stresses or the risk of brittle fracture, or is otherwise impracticable, the required strength may be obtained through additional supports, braces, or other means without an increased wall thickness. Particular consideration should be given to the mechanical strength of small pipe connections to piping or equipment.

**Table IP-2.2.9-1  
Longitudinal Weld Joint Quality Factor,  $E_j$**

| No. | Type of Joint  | Type of Seam                                | Examination  | Factor, $E_j$        |
|-----|--|---|--|----------------------|
| 1   | Electric resistance weld<br>  | Straight                                    | As required by listed specifications   | 1.00                 |
| 2   | Electric fusion weld   |   |  |                      |
|     | (a) Single butt weld<br>(with or without filler metal)<br>                                  | Straight                                    | As required by listed specifications or this Code<br>Additionally spot radiographed [Note (1)]<br>Additionally 100% radiographed per para. IP-10.4.5.3 and Table IP-10.4.3-1 | 0.80<br>0.90<br>1.00 |
|     | (b) Double butt weld<br>(with or without filler metal)<br>                                  | Straight<br>[except as provided in 3 below] | As required by listed specifications or this Code<br>Additionally spot radiographed [Note (1)]<br>Additionally 100% radiographed per para. IP-10.4.5.3 and Table IP-10.4.3-1 | 0.85<br>0.90<br>1.00 |
| 3   | Per other specifications   |   |  |                      |
|     | API 5L<br>Submerged arc weld (SAW)<br>Gas metal arc weld (GMAW)<br>Combined GMAW, SAW<br> | Straight with one or two seams              | As required by specification   | 0.95                 |

NOTE: (1) Spot radiography for longitudinal groove welds required to have a weld joint factor,  $E_j$ , of 0.90 requires examination by radiography in accordance with para. IP-10.4.5.3 of at least 300 mm (1 ft) in each 30 m (100 ft) of weld for each welder. Acceptance criteria are those stated in Table IP-10.4.3-1 for radiography for the type of joint examined.

# Chapter IP-3 Pressure Design of Piping Components

## IP-3.1 GENERAL

(a) Components manufactured in accordance with standards listed in [Table IP-8.1.1-1](#) shall be considered suitable for use at pressure-temperature ratings in accordance with [para. IP-2.2.2](#) or [para IP-2.2.3](#), as applicable. The rules in [para. IP-3.2](#) are intended for pressure design of components not covered in [Table IP-8.1.1-1](#), but may be used for a special or more rigorous design of such components, or to satisfy requirements of [para. IP-2.2.3](#).

(b) Designs shall be checked for adequacy of mechanical strength under applicable loadings enumerated in [para. IP-2.1](#). Adequacy of mechanical strength may be demonstrated by methods described in CSA HGV 4.10, Fittings for Compressed Hydrogen Gas and Hydrogen Rich Gas Mixtures.

## IP-3.2 STRAIGHT PIPE

(a) The required thickness of straight sections of pipe shall be determined in accordance with [eq. \(2\)](#)

$$t_m = t + c \tag{2}$$

The minimum thickness,  $T$ , for the pipe selected, considering the manufacturer's minus tolerance, shall be not less than  $t_m$ .

(b) The following nomenclature is used in the equations for pressure design of straight pipe:

$c$  = sum of the mechanical allowances (thread or groove depth) plus corrosion and erosion allowances. For threaded components, the nominal thread depth (dimension  $h$  of ASME B1.20.1, or equivalent) shall apply. For machined surfaces or grooves where the tolerance is not specified, the tolerance shall be assumed to be 0.5 mm (0.02 in.) in addition to the specified depth of the cut.

$D$  = outside diameter of pipe as listed in tables of standards or specifications, or as measured

$d$  = inside diameter of pipe. For pressure design calculation, the inside diameter of the pipe is the maximum value allowable under the purchase specification.

$E$  = quality factor from [Mandatory Appendix IX, Table IX-2](#) or [Table IX-3A](#)

$M_f$  = material performance factor that addresses loss of material properties associated with hydrogen gas service. See [Mandatory Appendix IX](#) for performance factor tables and application notes.

$P$  = internal design gage pressure

$S$  = stress value for material from [Mandatory Appendix IX, Table IX-1A](#)

$T$  = pipe wall thickness (measured or minimum per purchase specification)

$t$  = pressure design thickness, as calculated in accordance with [para. IP-3.2.1](#) for internal pressure or as determined in accordance with [para. IP-3.2.2](#) for external pressure

$t_m$  = minimum required thickness, including mechanical, corrosion, and erosion allowances

$Y$  = coefficient from [Table IP-3.2-1](#), valid for  $t < D/6$  and for materials shown. The value of  $Y$  may be interpolated for intermediate temperatures.

$$= (d + 2c)/(D + d + 2c) \text{ for } t \geq D/6$$

### IP-3.2.1 Straight Pipe Under Internal Pressure

(a) For  $t < D/6$ , the internal pressure design thickness for straight pipe shall be not less than that calculated in accordance with either [eq. \(3a\)](#) or [eq. \(3b\)](#):

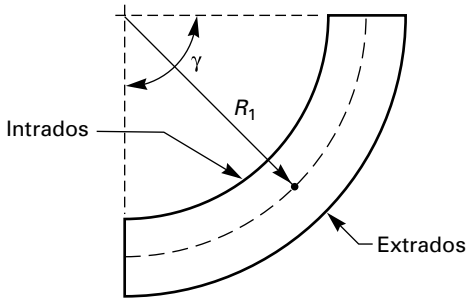
$$t = \frac{PD}{2(SEM_f + PY)} \tag{3a}$$

**Table IP-3.2-1  
Values of Coefficient Y for  $t < D/6$**

| Materials         | Coefficient Y at Temperature, °C (°F) |              |                |                |                |                  |
|-------------------|---------------------------------------|--------------|----------------|----------------|----------------|------------------|
|                   | ≤482<br>(≤900)                        | 510<br>(950) | 538<br>(1,000) | 566<br>(1,050) | 593<br>(1,100) | ≥621<br>(≥1,150) |
| Ferritic steels   | 0.4                                   | 0.5          | 0.7            | 0.7            | 0.7            | 0.7              |
| Austenitic steels | 0.4                                   | 0.4          | 0.4            | 0.4            | 0.5            | 0.7              |



**Figure IP-3.3.1-1  
Nomenclature for Pipe Bends**



$$t = \frac{PD}{2[SEM_f + P(1 - Y)]} \quad (3b)$$

(b) For  $t \geq D/6$  or for  $P/SEM_f > 0.385$ , calculation of pressure design thickness for straight pipe requires special consideration of factors such as theory of failure, effects of fatigue, and thermal stress.

**IP-3.2.2 Straight Pipe Under External Pressure**

To determine wall thickness and stiffening requirements for straight pipe under external pressure, the procedure outlined in ASME BPVC, Section VIII, Division 1, UG-28 through UG-30 shall be followed, using as the design length,  $L$ , the running centerline length between any two sections stiffened in accordance with UG-29. As an exception, for pipe with  $D_o/t < 10$ , the value of  $S$  to be used in determining  $P_{a2}$  shall be the lesser of the following values for pipe material at design temperature:

(a) 1.5 times the stress value from **Mandatory Appendix IX, Table IX-1A** of this Code

(b) 0.9 times the yield strength tabulated in ASME BPVC, Section II, Part D, Table Y-1 for materials listed therein

(The symbol  $D_o$  in ASME BPVC, Section VIII is equivalent to  $D$  in this Code.)

**IP-3.3 CURVED AND MITERED SEGMENTS OF PIPE**

**IP-3.3.1 Pipe Bends**

The minimum required thickness,  $t_m$ , of a bend, after bending, in its finished form shall be determined in accordance with **eqs. (2) and (3c)**

$$t = \frac{PD}{2(SEM_f/I + PY)} \quad (3c)$$

where at the intrados (inside bend radius)

$$I = \frac{4(R_1/D) - 1}{4(R_1/D) - 2} \quad (3d)$$

at the extrados (outside bend radius)

$$I = \frac{4(R_1/D) + 1}{4(R_1/D) + 2} \quad (3e)$$

and at the sidewall on the bend centerline radius,  $I = 1.0$ . In **eqs. (3d) and (3e)**,

$R_1$  = bend radius of welding elbow or pipe bend

Thickness variations from the intrados to the extrados and along the length of the bend shall be gradual. The thickness requirements apply at the midspan of the bend,  $y/2$ , at the intrados, extrados, and bend centerline radius. The minimum thickness at the end tangents shall not be less than the requirements of **para. IP-3.2** for straight pipe (see **Figure IP-3.3.1-1**).

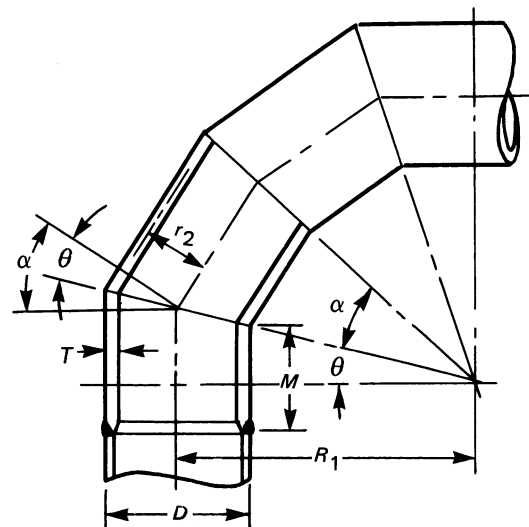
**IP-3.3.2 Elbows**

Manufactured elbows not in accordance with **para. IP-3.1** shall be qualified as required by **para. IP-3.8.2** or designed in accordance with **para IP-3.3.1**, except as provided in **para. GR-3.4.3(d)(6)**.

**IP-3.3.3 Miter Bends**

An angular offset of 3 deg or less (angle  $\alpha$  in **Figure IP-3.3.3-1**) does not require design consideration as a miter bend. Mitered joints may be used in liquid hydrogen piping under the following conditions: a joint stress analysis has been performed and engineering design has approved the joint, the number of full-pressure or thermal cycles will not exceed 7 000 during the expected lifetime of the pipe system, and complete joint penetration welds shall be used in joining miter segments. Acceptable

**Figure IP-3.3.3-1  
Nomenclature for Miter Bends**



methods for pressure design of multiple and single miter bends are given in (a) and (b) below.

(a) *Multiple Miter Bends.* The maximum allowable internal pressure shall be the lesser value calculated from eqs. (4a) and (4b). These equations are not applicable when  $\theta$  exceeds 22.5 deg.

$$P_m = \frac{SEM_f(T - c)}{r_2} \left[ \frac{T - c}{(T - c) + 0.643 \tan \theta \sqrt{r_2(T - c)}} \right] \quad (4a)$$

$$P_m = \frac{SEM_f(T - c)}{r_2} \left( \frac{R_1 - r_2}{R_1 - 0.5r_2} \right) \quad (4b)$$

(b) *Single Miter Bends*

(1) The maximum allowable internal pressure for a single miter bend with angle  $\theta$  not greater than 22.5 deg shall be calculated by eq. (4a).

(2) The maximum allowable internal pressure for a single miter bend with angle  $\theta$  greater than 22.5 deg shall be calculated by eq. (4c)

$$P_m = \frac{SEM_f(T - c)}{r_2} \left[ \frac{T - c}{(T - c) + 1.25 \tan \theta \sqrt{r_2(T - c)}} \right] \quad (4c)$$

(c) The miter pipe wall thickness,  $T$ , used in eqs. (4a), (4b), and (4c) shall extend a distance not less than  $M$  from the inside crotch of the end miter welds, where

$$M = \text{the larger of } 2.5(r_2T)^{0.5} \text{ or } \tan \theta(R_1 - r_2)$$

The length of taper at the end of the miter pipe may be included in the distance,  $M$ .

(d) The following nomenclature is used in eqs. (4a), (4b), and (4c) for the pressure design of miter bends:

- $c$  = same as defined in para. IP-3.2
- $E$  = same as defined in para. IP-3.2
- $M_f$  = same as defined in para. IP-3.2
- $P_m$  = maximum allowable internal pressure for miter bends
- $R_1$  = effective radius of miter bend, defined as the shortest distance from the pipe centerline to the intersection of the planes of adjacent miter joints
- $r_2$  = mean radius of pipe using nominal wall  $\bar{T}$
- $S$  = same as defined in para. IP-3.2
- $T$  = miter pipe wall thickness (measured or minimum per purchase specification)
- $\alpha$  = angle of change in direction at miter joint  
=  $2\theta$
- $\theta$  = angle of miter cut

For compliance with this Code, the value of  $R_1$  shall be not less than that given by eq. (5)

$$R_1 = \frac{A}{\tan \theta} + \frac{D}{2} \quad (5)$$

where  $A$  has the following empirical values:

(1) For SI (metric) units

|                       |                     |
|-----------------------|---------------------|
| $(T - c), \text{ mm}$ | $A$                 |
| $\leq 13$             | 25                  |
| $13 < (T - c) < 22$   | $2(T - c)$          |
| $\geq 22$             | $[2(T - c)/3] + 30$ |

(2) For U.S. Customary units

|                        |                       |
|------------------------|-----------------------|
| $(T - c), \text{ in.}$ | $A$                   |
| $\leq 0.5$             | 1.0                   |
| $0.5 < (T - c) < 0.88$ | $2(T - c)$            |
| $\geq 0.88$            | $[2(T - c)/3] + 1.17$ |

### IP-3.3.4 Curved and Mitered Segments of Pipe Under External Pressure

The wall thickness of curved and mitered segments of pipe subjected to external pressure may be determined as specified for straight pipe in para. IP-3.2.2.

### IP-3.4 BRANCH CONNECTIONS

(a) Except as provided in (b) below, the requirements in paras. IP-3.4.1 through IP-3.4.3 are applicable to branch connections made in accordance with the following methods:

- (1) fittings (tees, extruded outlets, branch outlet fittings per MSS SP-97, laterals, crosses)
- (2) unlisted cast or forged branch connection fittings (see para. GR-1.2) and couplings not over DN 80 (NPS 3), attached to the run pipe by welding
- (3) welding the branch pipe directly to the run pipe, with or without added reinforcement, as covered in para. GR-3.4.9

(b) The rules in paras. IP-3.4.1 through IP-3.4.3 are minimum requirements, valid only for branch connections in which (using the nomenclature of Figure IP-3.4.2-1)

- (1) the run pipe diameter-to-thickness ratio,  $D_h/T_h$ , is less than 100 and the branch-to-run diameter ratio,  $D_b/D_h$ , is not greater than 1.0
  - (2) for run pipe with  $D_h/T_h \geq 100$ , the branch diameter,  $D_b$ , is less than one-half the run diameter,  $D_h$
  - (3) angle  $\beta$  is at least 45 deg
  - (4) the axis of the branch intersects the axis of the run
- (c) Where the provisions of (a) and (b) above are not met, pressure design shall be qualified as required by para. IP-3.8.2.

(d) Other design considerations relating to branch connections are stated in para. IP-3.4.4.

#### IP-3.4.1 Strength of Branch Connections

A pipe having a branch connection is weakened by the opening that must be made in it and, unless the wall thickness of the pipe is sufficiently in excess of that required to sustain the pressure, it is necessary to provide added

reinforcement. The amount of reinforcement required to sustain the pressure shall be determined in accordance with [para. IP-3.4.2](#) or [para. IP-3.4.3](#). There are, however, certain branch connections that have adequate pressure strength or reinforcement as constructed. It may be assumed without calculation that a branch connection has adequate strength to sustain the internal and external pressure which will be applied to it if

(a) the branch connection utilizes a listed fitting in accordance with [Chapter IP-3](#).

(b) the branch connection is made by welding a threaded or socket welding coupling or half coupling directly to the run in accordance with [para. GR-3.4.9](#), provided the size of the branch does not exceed DN 50 (NPS 2) nor one-fourth the nominal size of the run. The minimum wall thickness of the coupling anywhere in the reinforcement zone (if threads are in the zone, wall thickness is measured from root of thread to minimum outside diameter) shall be not less than that of the unthreaded branch pipe. In no case shall a coupling or half coupling have a rating less than Class 2000 per ASME B16.11.

(c) the branch connection utilizes an unlisted branch connection fitting (see [para. GR-1.2](#)), provided the fitting is made from materials listed in [Mandatory Appendix IX, Table IX-1A](#) and provided that the branch connection is qualified as required by [para. IP-3.8.2](#).

### IP-3.4.2 Reinforcement of Welded Branch Connections

Added reinforcement is required to meet the criteria in (b) and (c) below when it is not inherent in the components of the branch connection. Sample problems illustrating the calculations for branch reinforcement are shown in [Nonmandatory Appendix E](#).

(a) *Nomenclature*. The following nomenclature is used in the pressure design of branch connections. It is illustrated in [Figure IP-3.4.2-1](#), which does not indicate details for construction or welding. Some of the terms defined in [Nonmandatory Appendix E, para. E-2](#) are subject to further definitions or variations, as follows:

- $b$  = subscript referring to branch
- $d_1$  = effective length removed from pipe at branch  
=  $[D_b - 2(T_b - c)]/\sin \beta$  for branch intersections where the branch opening is a projection of the branch pipe inside diameter (e.g., pipe-to-pipe fabricated branch)
- $d_2$  = half-width of reinforcement zone  
=  $d_1$  or  $(T_b - c) + (T_h - c) + d_1/2$ , whichever is greater, but in any case not more than  $D_h$
- $h$  = subscript referring to run or header
- $L_4$  = height of reinforcement zone outside of run pipe  
=  $2.5(T_h - c)$  or  $2.5(T_b - c) + T_r$ , whichever is less
- $t$  = pressure design thickness of pipe, according to the appropriate wall thickness equation or procedure in [para. IP-3.2](#). For welded pipe, when the

branch does not intersect the longitudinal weld of the run, the basic allowable stress,  $S$ , for the pipe may be used in determining  $t_h$  for reinforcement calculation only. When the branch does intersect the longitudinal weld of the run, the product  $SEW$  {of the stress value,  $S$ , the appropriate weld joint quality factor,  $E_j$ , from [Mandatory Appendix IX, Table IX-3A](#), and the weld joint strength reduction factor,  $W$  [see [para. IP-2.2.10\(a\)](#)]} for the run pipe shall be used in the calculation. The product  $SEW$  of the branch shall be used in calculating  $t_b$ .

$T_b$  = branch pipe thickness (measured or minimum per purchase specification) except for branch connection fittings (see [para. GR-1.2](#)). For such connections, the value of  $T_b$  for use in calculating  $L_4$ ,  $d_2$ , and  $A_3$  is the thickness of the reinforcing barrel (minimum per purchase specification), provided that the barrel thickness is uniform and extends at least to the  $L_4$  limit (see [Figure IP-3.4.2-1](#)).

$T_h$  = header pipe thickness (measured or minimum per purchase specification)

$T_r$  = minimum thickness of reinforcing ring or saddle made from pipe (use nominal thickness if made from plate)

= 0, if there is no reinforcing ring or saddle

$\beta$  = smaller angle between axes of branch and run

(b) *Required Reinforcement Area*. The reinforcement area,  $A_1$ , required for a branch connection under internal pressure is

$$A_1 = t_h d_1 (2 - \sin \beta) \quad (6a)$$

For a branch connection under external pressure, area  $A_1$  is one-half the area calculated by [eq. \(6a\)](#), using as  $t_h$  the thickness required for external pressure.

(c) *Available Area*. The area available for reinforcement is defined as

$$A_2 + A_3 + A_4 \geq A_1 \quad (6b)$$

These areas are all within the reinforcement zone and are further defined below.

(1) Area  $A_2$  is the area resulting from excess thickness in the run pipe wall

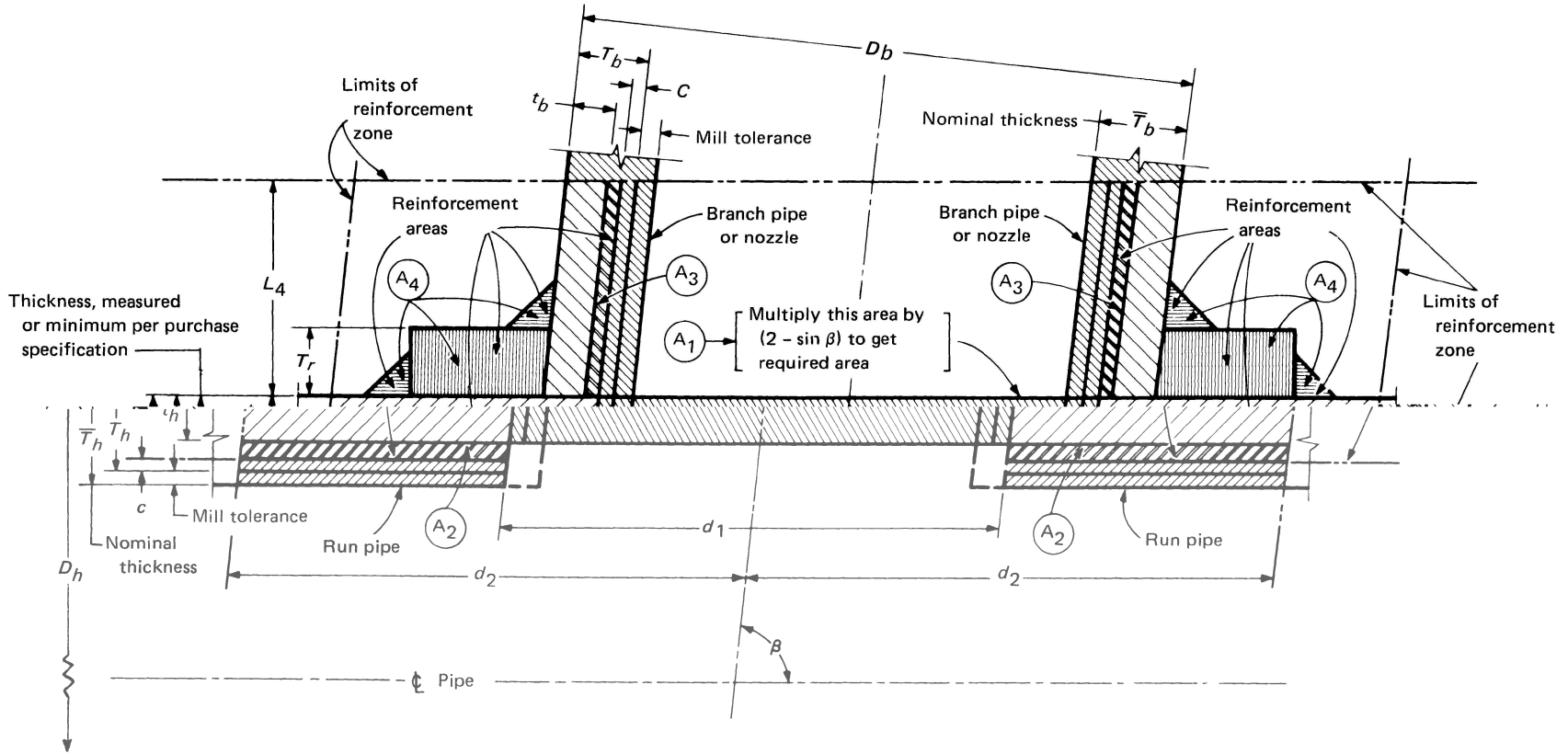
$$A_2 = (2d_2 - d_1)(T_h - t_h - c) \quad (7)$$

(2) Area  $A_3$  is the area resulting from excess thickness in the branch pipe wall

$$A_3 = 2L_4(T_b - t_b - C)/\sin \beta \quad (8)$$

If the allowable stress for the branch pipe wall is less than that for the run pipe, its calculated area must be reduced in the ratio of allowable stress values of the branch to the run in determining its contributions to area  $A_3$ .

**Figure IP-3.4.2-1  
Branch Connection Nomenclature**



GENERAL NOTE: This figure illustrates the nomenclature of [para. IP-3.4.2](#). It does not indicate complete welding details or a preferred method of construction. For typical weld details, see [Figure GR-3.4.9-2](#).

(3) Area  $A_4$  is the area of other metal provided by welds and properly attached reinforcement [see para. IP-3.4.2(f)]. Weld areas shall be based on the minimum dimensions specified in para. GR-3.4.9, except that larger dimensions may be used if the welder has been specifically instructed to make the welds to those dimensions.

(d) *Reinforcement Zone.* The reinforcement zone is a parallelogram whose length extends a distance of  $d_2$  on each side of the centerline of the branch pipe, and whose width starts at the inside surface of the run pipe (in its corroded condition) and extends beyond the outside surface of the run pipe a perpendicular distance  $L_4$ .

(e) *Multiple Branches.* When two or more branch connections are so closely spaced that their reinforcement zones overlap, the distance between centers of the openings should be at least  $1\frac{1}{2}$  times their average diameter, and the area of reinforcement between any two openings shall be not less than 50% of the total that both require. Each opening shall have adequate reinforcement in accordance with (b) and (c). No part of the metal cross section may apply to more than one opening or be evaluated more than once in any combined area. (Consult PFI ES-07 for detailed recommendations on spacing of welded nozzles.)

(f) *Added Reinforcement*

(1) Reinforcement added in the form of a ring or saddle as part of area  $A_4$  shall be of reasonably constant width. A vent hole shall be provided in accordance with para. GR-3.4.9(g).

(2) Material used for reinforcement may differ from that of the run pipe, provided it is compatible with run and branch pipes with respect to weldability, heat treatment requirements, galvanic corrosion, thermal expansion, etc.

(3) If the allowable stress for the reinforcement material is less than that for the run pipe, its calculated area must be reduced in the ratio of allowable stress values in determining its contribution to area  $A_4$ .

(4) No additional credit may be taken for a material having higher allowable stress value than the run pipe.

### IP-3.4.3 Reinforcement of Extruded Outlet Headers

(a) *Extruded Outlets.* The principles of reinforcement stated in para. IP-3.4.2 are essentially applicable to extruded outlet headers. An extruded outlet header is a length of pipe in which one or more outlets for branch connection have been formed by extrusion, using a die or dies to control the radii of the extrusion. The extruded outlet projects above the surface of the header a distance,  $h_x$ , at least equal to the external radius of the outlet,  $r_x$  (i.e.,  $h_x \geq r_x$ ). Extruded outlets in the run pipe, at the attachment of the branch pipe, should be butt-welded.

(b) *Pressure Design.* The rules in para. IP-3.4.3 are minimum requirements, valid only within the limits of geometry shown in Figure IP-3.4.3-1, and only where the axis of the outlet intersects and is perpendicular to the axis of the header. Where these requirements are not met, or where nonintegral material such as a ring, pad, or saddle has been added to the outlet, pressure design shall be qualified as required by para. IP-3.8.2.

(c) *Nomenclature.* The nomenclature used herein is illustrated in Figure IP-3.4.3-1. Note the use of subscript  $x$ , signifying extruded. Refer to para. IP-3.4.2(a) for nomenclature not listed here.

$d_x$  = design inside diameter of the extruded outlet, measured at the level of the outside surface of the header. This dimension is taken after removal of all mechanical and corrosion allowances and all thickness tolerances.

$d_2$  = half-width of reinforcement zone (equal to  $d_x$ )

$h_x$  = height of the extruded outlet. This must be equal to or greater than  $r_x$  [except as shown in Figure IP-3.4.3-1, illustration (b)].

$L_5$  = height of reinforcement zone

$$= 0.7\sqrt{D_b T_x}$$

$r_x$  = radius of curvature of external contoured portion of outlet, measured in the plane containing the axes of the header and branch

$T_x$  = corroded finished thickness of extruded outlet, measured at a height equal to  $r_x$  above the outside surface of the header

(d) *Limitations on Radius,  $r_x$ .* The external contour radius,  $r_x$ , is subject to the following limitations:

(1) minimum  $r_x$ : the lesser of  $0.05D_b$  or 38 mm (1.50 in.)

(2) maximum  $r_x$  shall not exceed

(-a) for  $D_b < \text{DN } 200$  (NPS 8), 32 mm (1.25 in.)

(-b) for  $D_b \geq \text{DN } 200$  (NPS 8),  $0.1D_b + 13$  mm (0.50 in.)

(3) for an external contour with multiple radii, the requirements of (1) and (2) above apply, considering the best-fit radius over a 45 deg arc as the maximum radius

(4) machining shall not be employed to meet the above requirements

(e) *Required Reinforcement Area.* The required area of reinforcement is defined by

$$A_1 = Kt_h d_x \quad (9a)$$

where  $K$  is determined as follows:

(1) for  $D_b/D_h > 0.60$ ,  $K = 1.00$

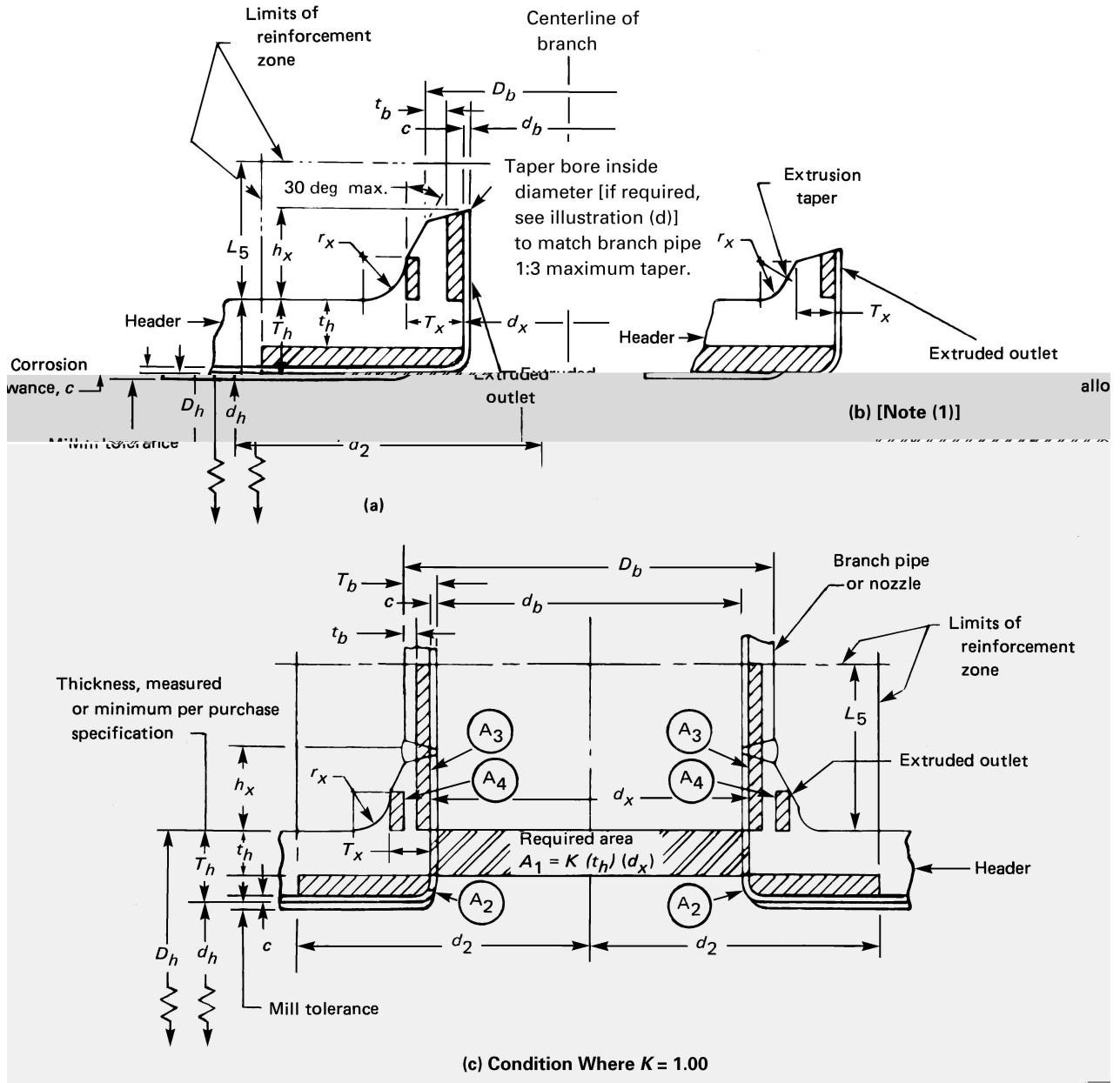
(2) for  $0.60 \geq D_b/D_h > 0.15$ ,  $K = 0.6 + \frac{2}{3}(D_b/D_h)$

(3) for  $D_b/D_h \leq 0.15$ ,  $K = 0.70$

(f) *Available Area.* The area available for reinforcement is defined as

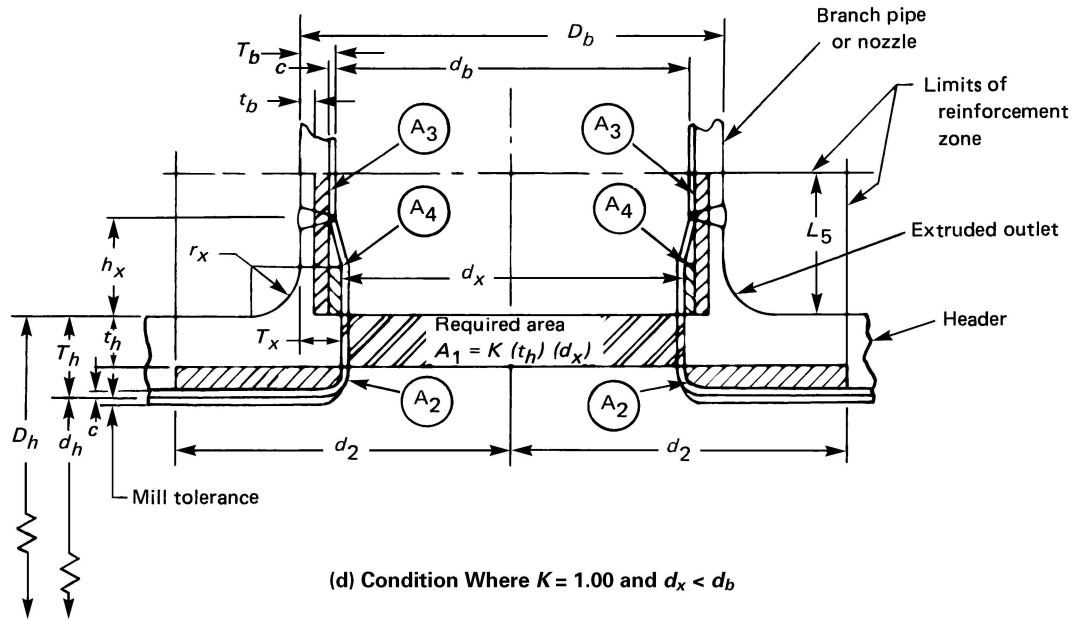
$$A_2 + A_3 + A_4 \geq A_1 \quad (9b)$$

**Figure IP-3.4.3-1**  
**Extruded Outlet Header Nomenclature**





**Figure IP-3.4.3-1**  
**Extruded Outlet Header Nomenclature (Cont'd)**



GENERAL NOTE: This figure illustrates the nomenclature of [para. IP-3.4.3](#). It does not indicate complete details or a preferred method of construction.

NOTE: (1) Illustration (b) shows method of establishing  $T_x$  when the taper encroaches on the crotch radius.

These areas are all within the reinforcement zone and are further defined below.

(1) Area  $A_2$  is the area resulting from excess thickness in the header wall

$$A_2 = (2d_2 - d_x)(T_h - t_h - c) \quad (10)$$

(2) Area  $A_3$  is the area resulting from excess thickness in the branch pipe wall

$$A_3 = 2L_5(T_b - t_b - c) \quad (11)$$

(3) Area  $A_4$  is the area resulting from excess thickness in the extruded outlet lip

$$A_4 = 2r_x[T_x - (T_b - c)] \quad (12)$$

(g) *Reinforcement of Multiple Openings.* The rules of [para. IP-3.4.2\(e\)](#) shall be followed, except that the required area and reinforcement area shall be as given in [para. IP-3.4.3](#).

(h) *Identification.* The manufacturer shall establish the design pressure and temperature for each extruded outlet header and shall mark the header with this information, together with the symbol "B31.12" (indicating the applicable Code Section) and the manufacturer's name or trademark.

### IP-3.4.4 Additional Design Considerations

The requirements of [paras. IP-3.4](#) through [IP-3.4.3](#) are intended to ensure satisfactory performance of a branch connection subject only to pressure. Engineering design shall also consider the following:

(a) In addition to pressure loadings, external forces and movements are applied to a branch connection by thermal expansion and contraction, dead and live loads, and movement of piping terminals and supports. Special consideration shall be given to the design of a branch connection to withstand these forces and movements.

(b) Branch connections made by welding the branch pipe directly to the run pipe should be avoided under the following circumstances:

(1) when branch size approaches run size, particularly if pipe formed by more than 1.5% cold expansion, or expanded pipe of a material subject to work hardening, is used as the run pipe

(2) where repetitive stresses may be imposed on the connection by vibration, pulsating pressure, temperature cycling, etc.

In such cases, it is recommended that the design be conservative and that consideration be given to the use of tee fittings or complete encirclement types of reinforcement.



**Table IP-3.5-1**  
**ASME BPVC, Section VIII, Division 1**  
**References for Closures**

| Type of Closure                    | Concave to Pressure | Convex to Pressure |
|------------------------------------|---------------------|--------------------|
| Ellipsoidal                        | UG-32(d)            | UG-33(d)           |
| Torispherical                      | UG-32(e)            | UG-33(e)           |
| Hemispherical                      | UG-32(f)            | UG-33(c)           |
| Conical (no transition to knuckle) | UG-32(g)            | UG-33(f)           |
| Toriconical                        | UG-32(h)            | UG-33(f)           |
| Flat (pressure on either side)     | UG-34               |                    |

(c) Adequate flexibility shall be provided in a small line that branches from a large run, to accommodate thermal expansion and other movements of the larger line. Calculations of displacements and rotations at specific locations may be required where clearance problems are involved. In cases where small-size branch pipes attached to stiffer run pipes are to be calculated separately, the linear and angular movements of the junction point must be calculated or estimated for proper analysis of the branch.

(d) If ribs, gussets, or clamps are used to stiffen the branch connection, their areas cannot be counted as contributing to the reinforcement area determined in para. IP-3.4.2(c) or para. IP-3.4.3(f). However, ribs or gussets may be used for pressure-strengthening a branch connection in lieu of reinforcement covered in paras. IP-3.4.2 and IP-3.4.3 if the design is qualified as required by para. IP-3.8.2.

(e) For branch connections that do not meet the requirements of para. IP-3.4(b), integral reinforcement, complete encirclement reinforcement, or other means of reinforcement should be considered.

### IP-3.4.5 Branch Connections Under External Pressure

Pressure design for a branch connection subjected to external pressure may be determined in accordance with para. IP-3.4, using the reinforcement area requirement stated in para. IP-3.4.2(b).

## IP-3.5 CLOSURES

(a) Closures not in accordance with either para. IP-3.1 or (b) below shall be qualified as required by para. IP-3.8.2.

(b) For materials and design conditions covered therein, closures may be designed in accordance with the rules in ASME BPVC, Section VIII, Division 1, calculated from eq. (13):

$$t_m = t + c \quad (13)$$

where

$c$  = sum of allowances defined in para. IP-3.2

$t$  = pressure design thickness, calculated for the type of closure and direction of loading, shown in Table IP-3.5-1, except that the symbols used to determine  $t$  shall be

$E$  = same as defined in para. IP-3.2

$P$  = design gage pressure

$S$  =  $S$  times  $W$  and  $M_f$ , with  $S$ ,  $M_f$ , and  $W$  as defined in para. IP-3.2

$t_m$  = minimum required thickness, including mechanical, corrosion, and erosion allowance

### (c) Openings in Closures

(1) The rules in (2) through (7) apply to openings not larger than one-half the inside diameter of the closure as defined in ASME BPVC, Section VIII, Division 1, UG-36. A closure with a larger opening should be designed as a reducer in accordance with para. IP-3.7 or, if the closure is flat, as a flange in accordance with para. IP-3.6.

(2) A closure is weakened by an opening and, unless the thickness of the closure is sufficiently in excess of that required to sustain pressure, it is necessary to provide added reinforcement. The need for and amount of reinforcement required shall be determined in accordance with the subparagraphs below except that it shall be considered that the opening has adequate reinforcement if the outlet connection meets the requirements in para. IP-3.4.1(b) or para. IP-3.4.1(c).

(3) Reinforcement for an opening in a closure shall be so distributed that reinforcement area on each side of an opening (considering any plane through the center of the opening normal to the surface of the closure) will equal at least one-half the required area in that plane.

(4) The total cross-sectional area required for reinforcement in any given plane passing through the center of the opening shall not be less than that defined in ASME BPVC, Section VIII, Division 1, UG-37(b), UG-38, and UG-39.

(5) The reinforcement area and reinforcement zone shall be calculated in accordance with para. IP-3.4.2 or IP-3.4.3, considering the subscript  $h$  and other references to the run or header pipe as applying to the closure. Where the closure is curved, the boundaries of the reinforcement zone shall follow the contour of the closure, and dimensions of the reinforcement zone shall be measured parallel to and perpendicular to the closure surface.

(6) If two or more openings are to be located in a closure, the rules in paras. IP-3.4.2 and IP-3.4.3 for the reinforcement of multiple openings apply.

(7) The additional design considerations for branch connections discussed in para. IP-3.4.4 apply equally to openings in closures.

## IP-3.6 PRESSURE DESIGN OF FLANGES AND BLANKS

### IP-3.6.1 Flanges

(a) Flanges not in accordance with [para. IP-3.1](#) or (b) or (c) below shall be qualified as required by [para. IP-3.8.2](#).

(b) A flange may be designed in accordance with ASME BPVC, Section VIII, Division 1, Appendix 2, using the allowable stresses and temperature limits of this Code. Nomenclature shall be as defined in Appendix 2 except as follows:

$P$  = design gage pressure

$S_a$  = bolt design stress at atmospheric temperature

$S_b$  = bolt design stress at design temperature

$S_f$  = product  $SEM_f$  [of the stress value,  $S$ ; the appropriate quality factor,  $E$ , from [Mandatory Appendix IX, Table IX-2](#) or [Table IX-3A](#); and the performance factor,  $M_f$  (see [Mandatory Appendix IX](#))] for flange or pipe material; see [para. IP-2.2.7\(c\)](#).

(c) The rules in (b) above are not applicable to a flanged joint having a gasket that extends outside the bolts (usually to the outside diameter of the flange). For flanges that make solid contact outside the bolts, ASME BPVC, Section VIII, Division 1, Appendix Y should be used.

(d) See ASME BPVC, Section VIII, Division 1, Appendix S or ASME PCC-1 for considerations applicable to bolted joint assembly.

### IP-3.6.2 Blind Flanges

(a) Blind flanges not in accordance with either [para. IP-3.1](#) or (b) below shall be qualified as required by [para. IP-3.8.2](#).

(b) A blind flange may be designed in accordance with [eq. \(14\)](#). The minimum thickness, considering the manufacturer's minus tolerance, shall be not less than  $t_m$

$$t_m = t + c \quad (14)$$

To calculate  $t$ , the rules of ASME BPVC, Section VIII, Division 1, UG-34 may be used with the following changes in nomenclature:

$c$  = sum of allowances defined in [para. IP-3.2](#)

$P$  = internal or external design gage pressure

$S_f$  = product  $SEM_f$  [of the stress value,  $S$ ; the appropriate quality factor,  $E$ , from [Mandatory Appendix IX, Table IX-2](#) or [Table IX-3A](#); and the material performance factor,  $M_f$  (see [Mandatory Appendix IX](#))] for flange material; see [para. IP-2.2.10](#)

$t$  = pressure design thickness, as calculated for the given styles of blind flange, using the appropriate equations for bolted flat cover plates in ASME BPVC, Section VIII, Division 1, UG-34

### IP-3.6.3 Blanks

The minimum required thickness of a permanent blank (representative configurations shown in [Figure IP-3.6.3-1](#)) shall be calculated in accordance with [eq. \(15\)](#)

$$t_m = d_g \sqrt{\frac{3P}{16SEM_f} + c} \quad (15)$$

where

$c$  = sum of allowances defined in [para. IP-3.2](#)

$d_g$  = inside diameter of gasket for raised or flat-face flanges, or the gasket pitch diameter for ring joint and fully retained gasketed flanges

$E$  = same as defined in [para. IP-3.2](#)

$M_f$  = same as defined in [para. IP-3.2](#)

$P$  = design gage pressure

$S$  = same as defined in [para. IP-3.2](#)

## IP-3.7 REDUCERS

### IP-3.7.1 Concentric Reducers

(a) Concentric reducers not in accordance with [para. IP-3.1](#) or (b) below shall be qualified as required by [para. IP-3.8.2](#).

(b) Concentric reducers made in a conical or reversed curve section, or a combination of such sections, may be designed in accordance with the rules for conical and tori-conical closures stated in [para. IP-3.5](#).

### IP-3.7.2 Eccentric Reducers

Eccentric reducers not in accordance with [para. IP-3.1](#) shall be qualified as required by [para. IP-3.8.2](#).

## IP-3.8 PRESSURE DESIGN OF OTHER COMPONENTS

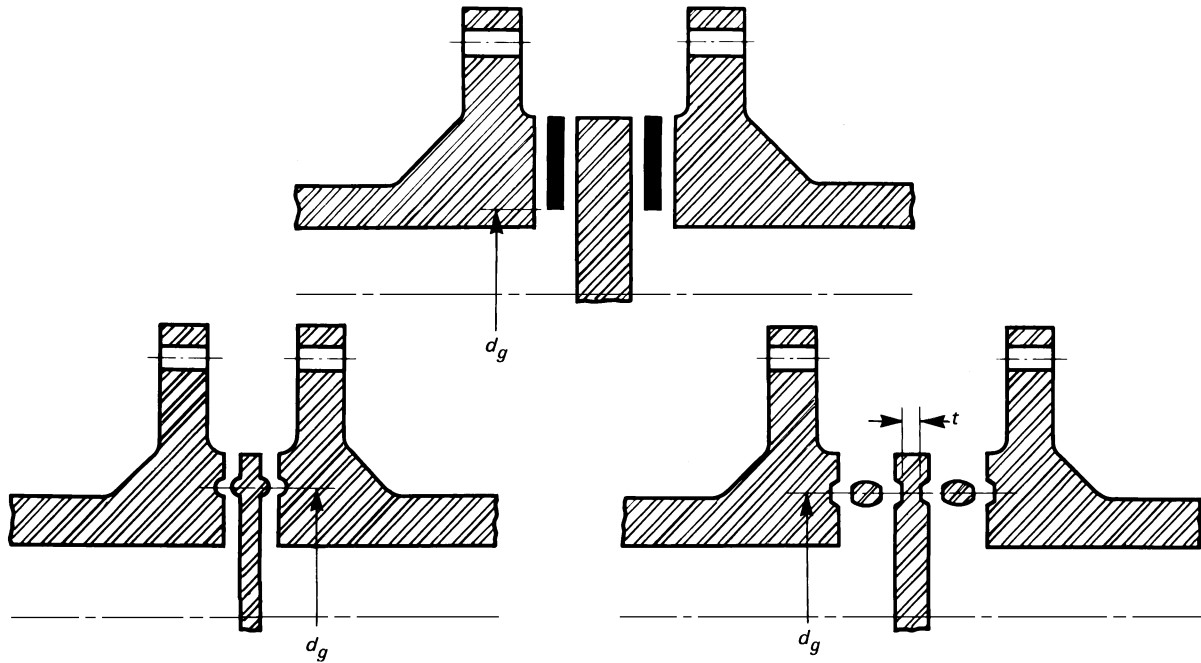
### IP-3.8.1 Listed Components

Other pressure-containing components manufactured in accordance with standards in [Table IP-8.1.1-1](#) may be utilized in accordance with [para. IP-3.1](#).

### IP-3.8.2 Unlisted Components and Elements

Pressure design of unlisted components and other piping elements to which the rules in [para. IP-3.1](#) do not apply shall be based on calculations consistent with the design criteria of this Code. These calculations shall be substantiated by one or more of the means stated in (a) through (d) below, considering applicable dynamic, thermal, and cyclic effects in [paras. IP-2.1.7](#) through [IP-2.1.8](#), as well as thermal shock. Calculations and documentation showing compliance with (a), (b), (c) or (d), and (e) shall be available for the owner's approval.

Figure IP-3.6.3-1  
Blanks



(a) extensive, successful service experience under comparable conditions with similarly proportioned components of the same or like material.

(b) experimental stress analysis, such as described in ASME BPVC, Section VIII, Division 2, Annex 5-F.

(c) proof test in accordance with ASME B16.9, MSS SP-97, CSA HGV 4.10, or ASME BPVC, Section VIII, Division 1, UG-101.

(d) detailed stress analysis (e.g., finite element method) with results evaluated as described in ASME BPVC, Section VIII, Division 2, Part 5. The basic allowable stress from [Mandatory Appendix IX, Table IX-1A](#) shall be used in place of the allowable stress,  $S$ , in ASME BPVC, Section VIII, Division 2, where applicable. At design temperatures in the creep range, additional considerations beyond the scope of Division 2 may be necessary.

(e) For any of the means stated in (a) through (d), the design engineer may interpolate between sizes, wall thicknesses, and pressure classes, and may determine analogies among related materials.

### IP-3.8.3 Metallic Components With Nonmetallic Pressure Parts

Components not covered by standards listed in [Table IP-8.1.1-1](#), in which both metallic and nonmetallic parts contain the pressure, shall be evaluated by applicable requirements of [para. IP-3.8.2](#).

### IP-3.8.4 Expansion Joints

(a) The design of metallic bellows-type expansion joints shall be in accordance with ASME B31.3, Appendix X. See also [Nonmandatory Appendix A](#) of this Code for further design considerations.

(b) The design of other types of expansion joints shall be qualified as required by [para. IP-3.8.2](#).

(c) Bellows-type expansion joints used in hydrogen piping systems may be convoluted or toroidal, and may or may not be reinforced. (Lap-welded tubing shall not be used.)

(d) Although a fatigue life able to withstand the full thermal motion cycles shall be a design requirement, in no case shall the life of the bellows be less than 1 000 full thermal movement and pressure cycles.

(e) Expansion joints shall be marked to show the direction of flow. Unless otherwise stated in the design specifications, flow liners shall be provided when flow velocities exceed the following values:

| Expansion Joint Diameter, in. | Gas, ft/sec | Liquid, ft/sec |
|-------------------------------|-------------|----------------|
| ≤6                            | 4           | 2              |
| >6                            | 25          | 10             |

*(f)* In all piping systems containing bellows, the hydrostatic end force caused by pressure, as well as the bellows spring force and rigid external anchors or a tie rod configuration, must resist the guide friction force.

*(g)* The expansion joints shall be installed in locations accessible for scheduled inspection and all circumferential welds should be 100% radiographed to assure quality welds.

## Chapter IP-4

# Service Requirements for Piping Components

### IP-4.1 VALVES AND SPECIALTY COMPONENTS

The following requirements for valves shall also be met, as applicable, by other pressure-containing piping components, such as traps, strainers, and separators. See [Nonmandatory Appendix A, para. A-7](#) for valve selection considerations.

#### IP-4.1.1 Valves

(a) *Listed Valves.* Valve standards listed in [Table IP-8.1.1-1](#) are suitable for use, except as stated in [para. IP-4.1.2](#).

(b) *Unlisted Valves.* Unlisted valves may be used only in accordance with [para. IP-2.2.4](#), unless pressure-temperature ratings are established by the method set forth in ASME B16.34.

#### IP-4.1.2 Specific Requirements

A bolted bonnet valve, whose bonnet is secured to the body by fewer than four bolts or by a U-bolt, shall not be used.

### IP-4.2 BOLTING AND TAPPED HOLES FOR COMPONENTS

(a) *Bolting.* Bolting for components conforming to a listed standard shall be in accordance with that standard if specified therein.

(b) *Tapped Holes.* Tapped holes for pressure-retaining bolting in metallic piping components shall be of sufficient depth that the thread engagement will be at least seven-eighths of the nominal thread diameter.

## Chapter IP-5

# Service Requirements for Piping Joints

### IP-5.1 SCOPE

Piping joints shall be selected to suit the piping material, with consideration of joint tightness and mechanical strength under expected service and test conditions of pressure, temperature, and external loading. Layout of piping should, insofar as possible, minimize stress on joints, giving special consideration to stresses due to thermal expansion and operation of valves (particularly a valve at a free end).

### IP-5.2 WELDED JOINTS

Joints may be made by welding in any material for which it is possible to qualify welding procedures, welders, and welding operators in conformance with the rules in [para. IP-9.2](#).

#### IP-5.2.1 Welding Requirements

Welds shall conform to the following:

- (a) Welding shall be in accordance with [para. IP-9.6.1](#).
- (b) Preheating and heat treatment shall be in accordance with [para. IP-9.9](#).
- (c) Examination shall be in accordance with [Chapter IP-10](#).
- (d) Acceptance criteria shall be those in [Tables IP-10.4.3-1](#) and [IP-10.4.3-2](#).

#### IP-5.2.2 Specific Requirements

(a) *Backing Rings and Consumable Inserts.* If backing rings are used where the resulting crevice is detrimental, e.g., subject to embrittlement, corrosion, vibration, or other degradation resulting from service, they shall be removed and the internal joint faces ground smooth. When it is impractical to remove the backing rings, welding without backing rings or using consumable inserts or removable nonmetallic backing rings should be considered.

(b) *Socket Welds*

(1) Socket welded joints (see [para. GR-3.4.7](#)) should be avoided where crevice corrosion or severe erosion may occur.

(2) A drain or bypass in a component may be attached by socket welding, provided the socket dimensions conform to Figure 4 in ASME B16.5.

(c) *Fillet Welds*

(1) Fillet welds in accordance with [para. GR-3.4.7](#) may be used as primary welds to attach socket welding components and slip-on flanges.

(2) Fillet welds may also be used to attach reinforcement and structural attachments, to supplement the strength or reduce stress concentration of primary welds, and to prevent disassembly of joints.

(d) *Seal Welds.* Seal welds (see [para. GR-3.4.8](#)) may be used only to prevent leakage of threaded joints and shall not be considered as contributing any strength to the joints.

### IP-5.3 FLANGED JOINTS

#### IP-5.3.1 Listed and Unlisted Flange Joints

(a) *Listed Flange Joints.* Listed flanges, blanks, and gaskets are suitable for use, except as stated elsewhere in [para. IP-5.3](#).

(b) *Unlisted Flange Joints.* Unlisted flanges, blanks, and gaskets may be used only in accordance with [para. IP-2.2.4](#).

#### IP-5.3.2 Selection, Design, and Installation of Flanged Joints

The following factors should be considered for leak-free flanged joints:

- (a) service conditions, e.g., external loads, bending moments, and thermal insulation
- (b) flange rating, type, material, facing, and facing finish
- (c) design for access to the joint
- (d) installation (see ASME PCC-1)
  - (1) condition of flange mating surfaces
  - (2) joint alignment and gasket placement before bolt up
  - (3) specifications for tightening bolts (see [para. IP-5.3.5](#))
  - (4) implementation of specified assembly procedures

#### IP-5.3.3 Flange Facings

Flange facings shall be suitable for the intended service and for the gaskets and bolting employed.

### IP-5.3.4 Flange Gaskets

(a) *Seating Load.* Gaskets shall be selected so that the required seating load is compatible with the flange rating, facing, strength of the flange, and bolting.

(b) *Materials.* Gasket materials shall be suitable for the service conditions. Gasket materials not subject to cold flow should be considered for temperatures significantly above or below ambient.

(c) *Full-Face Gaskets.* Use of full-face gaskets with flat-faced flanges should be considered when using gasket materials subject to cold flow for low pressure and vacuum services at moderate temperatures. When such gasket materials are used in other fluid services, the use of tongue and groove or other gasket-confining flange facings should be considered.

(d) *Facing Finish.* The effect of flange facing finish should be considered in gasket material selection.

### (23) IP-5.3.5 Flange Bolting

Bolting includes bolts, bolt studs, studs, cap screws, nuts, and washers.

(a) *Bolting Procedures.* The use of controlled bolting procedures should be considered in high, low, and cycling temperature services, and under conditions involving vibration or fatigue, to reduce

(1) the potential for joint leakage due to differential thermal expansion

(2) the possibility of stress relaxation and loss of bolt tension

(b) *Thermal Cycling.* If stress relaxation and loss of bolt tension is possible due to thermal cycling, bolt hardware shall be strain hardened.

(c) *Bolting Materials.* Additional considerations for bolting materials are in the course of preparation.

(d) *Listed Flange Bolting.* Listed bolting is suitable for use, except as stated elsewhere in [Chapter IP-3](#).

(e) *Unlisted Flange Bolting.* Unlisted bolting may be used only in accordance with [para. IP-5.3](#).

(f) *Selection Criteria.* Bolting selected shall be adequate to seat the gasket and maintain joint tightness under all design conditions.

(g) *Specific Bolting*

(1) *Low Yield Strength Bolting.* Bolting having not more than 207 MPa (30 ksi) SMYS shall not be used for flanged joints rated ASME B16.5 Class 400 and higher, nor for flanged joints using metallic gaskets, unless calculations have been made showing adequate strength to maintain joint tightness.

(2) *Carbon Steel Bolting.* Except where limited by other provisions of this Code, carbon steel bolting may be used with nonmetallic gaskets in flanged joints rated ASME B16.5 Class 300 and lower for bolt metal temperatures at  $-29^{\circ}\text{C}$  to  $204^{\circ}\text{C}$  ( $-20^{\circ}\text{F}$  to  $400^{\circ}\text{F}$ ), inclusive. If these bolts are galvanized, heavy hexagon nuts, threaded to suit, shall be used.

(3) *Bolting for Metallic Flange Combinations.* Any bolting that meets the requirements of [para. IP-5.3.5](#) may be used with any combination of flange material and facing. If either flange is to the ASME B16.1, ASME B16.24, MSS SP-42, or MSS SP-51 specification, the bolting material shall be no stronger than low yield strength bolting unless

(-a) both flanges have flat faces and a full face gasket is used or

(-b) sequence and torque limits for bolt-up are specified, with consideration of sustained loads, displacement strains, and occasional loads (see [paras. IP-2.2.10](#) and [IP-2.2.11](#)), and strength of the flanges

### IP-5.3.6 Tapped Holes for Flange Bolting

Tapped holes for flange bolts shall be of sufficient depth that the thread engagement will be at least seven-eighths of the nominal thread diameter.

### IP-5.3.7 Joints Using Flanges of Different Ratings

Where flanges of different ratings are bolted together, the rating of the joint shall not exceed that of the lower rated flange. Bolting torque shall be limited so excessive loads are not imposed on the lower-rated flange.

### IP-5.3.8 Metal-to-Nonmetal Flanged Joints

Joints where a metallic flange is bolted to a nonmetallic flange should be avoided. However, when such joints are necessary, both flanges shall be flat faced and full-faced gaskets are preferred. If gaskets that extend only to the inner edge of the bolts are used, the bolting torque shall be limited to prevent overloading the nonmetallic flange.

### IP-5.3.9 Slip-On Flanges

(a) Slip-on flanges shall be double welded as shown in [Figure GR-3.4.7-2](#) when the service is

(1) subject to cyclic loading

(2) at temperatures below  $-101^{\circ}\text{C}$  ( $-150^{\circ}\text{F}$ )

(b) The space between the welds in double-welded slip-on flanges shall be vented.

(c) Slip-on flanges shall be avoided where many large temperature cycles are expected, particularly if the flanges are not insulated.

### IP-5.3.10 Socket Welding and Threaded Flanges

(a) Socket welding flanges are subject to the requirements for socket welding in [para. IP-5.2.2\(b\)](#).

(b) Threaded flanges are subject to the requirements for threaded joints in [para. IP-5.5](#).

## IP-5.4 EXPANDED JOINTS

(a) Adequate means shall be provided to prevent separation of the joint. Safeguarding is required.



(b) Consideration shall be given to the tightness of expanded joints when subjected to vibration, differential expansion or contraction due to temperature cycling, or external mechanical loads.

## IP-5.5 THREADED JOINTS

### IP-5.5.1 Taper-Threaded Joints

Requirements below apply to joints where the threads of both mating components conform to specifications for general purpose taper pipe threads, NPT, in accordance with ASME B1.20.1.

(a) *Below 20 670 kPa (3,000 psig).* Taper-threaded joints may be used on systems with design pressures below 20 670 kPa (3,000 psig).

(b) *20 670 kPa (3,000 psig) to 48 280 kPa (7,000 psig).* Taper-threaded joints may be used on systems with design pressures from 20 670 kPa (3,000 psig) through 48 280 kPa (7,000 psig) when specified by the engineering design.

(c) *Above 48 280 kPa (7,000 psig).* Taper-threaded joints shall not be used on systems with design pressures above 48 280 kPa (7,000 psig).

(d) *Taper-Threaded Joints.* For mechanical strength, male-threaded components shall be at least Schedule 160 in nominal wall thickness. The nominal thickness of Schedule 160 piping is listed in ASME B36.10M for DN 15 (NPS 1/2). Male-threaded components shall have a minimum wall thickness of the threaded section that results in stresses less than 50% of yield for piping listed in ASME B16.11 for sizes smaller than DN 15 (NPS 1/2). See [Table IP-8.1.1-1](#) for male-taper threaded components/joints. Provision should be made to counteract forces that would tend to unscrew taper-threaded joints.

(e) *Thread Sealants.* Taper-threaded joints with suitable thread sealants are acceptable for hydrogen gas inside buildings.

(f) *Seal Welding.* Seal welding taper-threaded joints should be considered for hydrogen gas inside buildings. Taper-threaded joints shall not be seal welded unless the composition of the metals in the joint is known and proper procedures for those metals are followed. Thread sealants shall not be used and the weld material shall cover the full circumferential length of the thread.

### IP-5.5.2 Straight-Threaded Joints

Threaded joints in which the tightness of the joint is provided by a seating surface other than the threads, e.g., a union comprising male and female ends joined with a threaded union nut, or other constructions shown typically in [Figure IP-9.14-1](#), may be used.

(a) *Straight-Threaded Joints Conforming to Listed Standards.* Straight-threaded joints listed in [Table IP-8.1.1-1](#) are suitable for use. Joint designs listed in [Table](#)

[IP-8.1.1-1](#) shall be qualified as required by [para. IP-3.8.2](#) and other requirements for straight-threaded joints to be determined. Joints listed in [Table IP-8.1.1-1](#) shall conform to ANSI-approved design standards that allow interchange and intermix of components from one manufacturer with those of another manufacturer.

(b) *Pressure Design of Unlisted Straight-Threaded Joints.* Straight-threaded joints not listed in [Table IP-8.1.1-1](#) may be used in accordance with [para. IP-5.5](#), provided that the type of fitting selected is also adequate for pressure and other loadings. The design shall be qualified as required by [para. IP-3.8.2](#) and other requirements to be determined for straight-threaded joints. Components of proprietary joints not listed in [Table IP-8.1.1-1](#) shall not be interchanged or intermixed with components from another manufacturer.

Pressure design of straight-threaded joints shall be based on calculations consistent with design requirements of this Code. These calculations shall be substantiated by testing in accordance with to-be-determined procedures and protocols. The testing shall consider such factors as assembly and disassembly, cyclic loading, vibration, shock, hydrogen embrittlement, thermal expansion and contraction, and other factors to be determined.

### IP-5.5.3 Tubing Joints

Flared, flareless, and compression-type tubing joints may be used. The tubing joints shall be suitable for the tubing to be used. Tubing components shall not be used beyond the pressure-temperature limits designated by the manufacturer or the applicable standards.

(a) *Tubing Joints Conforming to Listed Standards.* Tubing joint standards listed in [Table IP-8.1.1-1](#) are suitable for use. Designs shall be checked for adequacy of mechanical strength under applicable loadings enumerated in [para. IP-2.1](#).

(b) *Tubing Joints Not Conforming to Listed Standards.* The design shall be qualified as required by [para. IP-3.8.2](#). Designs shall be checked for adequate mechanical strength under applicable loadings enumerated in [para. IP-2.1](#). Designers shall also consider assembly and disassembly, hydrogen embrittlement, and other factors applicable to the particular application. Mating of components from different manufacturers shall be permitted only when specified in the engineering design.

## IP-5.6 CAULKED JOINTS

Caulked joints such as bell type joints shall not be used.

## IP-5.7 BRAZED AND SOLDERED JOINTS

### IP-5.7.1 Soldered Joints

Soldered joints and fillet joints made with solder metal shall not be used.

### IP-5.7.2 Brazed Joints

(a) Brazed joints are prohibited in piping systems with design conditions greater than Class 300.

(b) Brazed joints made in accordance with the provisions in [paras. GR-3.2, GR-3.8, IP-9.6.1, and IP-9.11](#) are suitable. They shall be safeguarded. The melting point of brazing alloys shall be considered where possible exposure to fire is involved.

(c) Fillet joints made with brazing filler metal are not permitted.

## IP-5.8 SPECIAL JOINTS

Special joints are those not covered in [paras. IP-5.1 through IP-5.7](#). The design shall be qualified as required by [para. IP-3.8.2](#) and other requirements to be determined. Specific requirements are as follows:

(a) *Joint Integrity*. Separation of the joint shall be prevented by a means with sufficient strength to withstand anticipated conditions of service.

(b) *Joint Interlocks*. Either mechanical or welded interlocks shall be provided to prevent separation of any joint.

(c) *Bell and Gland Type Joints*. Bell type and gland type joints shall not be used.

## Chapter IP-6 Flexibility and Support

(23)

### IP-6.1 ANALYSIS OF DISPLACEMENT LOADS

Analysis of displacement loads shall be in accordance with ASME B31.3, para. 319, except that the allowable displacement stress range shall be in accordance with [para. IP-2.2.10\(d\)](#).

### IP-6.2 ANALYSIS OF SUSTAINED LOADS

Analysis of sustained loads shall be in accordance with ASME B31.3, para. 320, except that the maximum stresses shall be as defined in [para. IP-2.2.10\(c\)](#).

### IP-6.3 PIPING SUPPORT

Piping support elements shall meet the requirements of ASME B31.3, para. 321.

## Chapter IP-7

# Specific Piping Systems

### IP-7.1 INSTRUMENT PIPING

#### IP-7.1.1 Scope

Instrument piping within the scope of this Code includes all piping and piping components used to connect instruments to other piping or equipment. It does not include instruments, or permanently sealed fluid-filled tubing systems furnished with instruments as temperature or pressure responsive devices.

#### IP-7.1.2 Requirements

Instrument piping shall meet the applicable requirements of the Code and the following:

(a) Consideration shall be given to the mechanical strength (including fatigue) of small instrument connections to piping or apparatus (see [para. IP-3.4.4](#)).

(b) When blowing down or bleeding instrument piping containing hydrogen, consideration shall be given to safe disposal.

### IP-7.2 PRESSURE-RELIEVING SYSTEMS

Pressure-relieving systems within the scope of this Code shall conform to the requirements of [paras. IP-7.2.1](#) through [IP-7.2.3](#).

#### IP-7.2.1 Stop Valves in Pressure-Relief Piping

When installing stop valves between piping and protective devices, or between protective devices and points of discharge, the stop valves shall meet the requirements of (a) or (b) and either (c) or (d), below.

(a) Full-area stop valves may be installed on the inlet and/or discharge side of pressure relieving devices.

(b) Stop valves of less than full area installed on the inlet and/or discharge side of pressure relieving devices shall not cause pressure drops that reduce the relieving capacity below that required, nor adversely affect the proper operation of the pressure relieving devices.

(c) Stop valves installed in pressure relief piping shall be so constructed or positively controlled that the closing of the maximum number of block valves possible at one

time will not reduce the pressure relieving capacity provided by the unaffected relieving devices below the required relieving capacity.

(d) As an alternative to (c) above, stop valves shall be so constructed and arranged that they can be locked or sealed in either the open or closed position.

#### IP-7.2.2 Pressure Relief Discharge Piping

Discharge lines from pressure relieving safety devices shall be designed to prevent accumulation of materials that may cause flow blockage, e.g., dirt, water, ice, etc. When discharging directly to the atmosphere, discharge shall not impinge on other piping or equipment and shall be directed away from platforms and other areas used by personnel. Reactions on the piping system due to actuation of safety relief devices shall be considered, and adequate strength shall be provided to withstand these reactions.

Consideration shall be given to the temperature increase of hydrogen during depressurization when designing a system (negative Joule-Thompson coefficient). Refer to CGA G-5.5 for additional guidance.

#### IP-7.2.3 Pressure-Relieving Devices

(23)

(a) Pressure-relieving devices required by [para. IP-2.1.3](#) shall be in accordance with ASME BPVC, Section VIII, Division 1, UG-125(c), UG-126, UG-127, and UG-132 through UG-136, excluding UG-135(e) and UG-136(c). The terms “design pressure”<sup>1</sup> and “piping system” shall be substituted for “maximum allowable working pressure” and “vessel,” respectively, in these paragraphs. The required relieving capacity of any pressure relieving device shall include consideration of all piping systems that it protects.

(b) Relief set pressure<sup>2</sup> shall be in accordance with ASME BPVC, Section VIII, Division 1.

(c) The maximum relieving pressure<sup>3</sup> shall be in accordance with ASME BPVC, Section VIII, Division 1.

<sup>1</sup> The “design pressure” for pressure relief is the maximum design pressure permitted, considering all components in the piping system.

<sup>2</sup> “Set pressure” is the pressure at which the device begins to relieve, e.g., lift pressure of a spring-actuated relief valve, bursting pressure of a rupture disk, or breaking pressure of a breaking pin device.

<sup>3</sup> “Maximum relieving pressure” is the maximum system pressure during a pressure relieving event.

# Chapter IP-8

## Dimensions and Ratings of Components

### IP-8.1 DIMENSIONAL REQUIREMENTS

#### IP-8.1.1 Listed Piping Components

Dimensional standards for piping components are listed in [Table IP-8.1.1-1](#). Dimensional requirements contained in specifications listed in [Mandatory Appendix IX](#) shall also be considered requirements of this Code.

#### IP-8.1.2 Unlisted Piping Components

Dimensions of piping components not listed in [Table IP-8.1.1-1](#) or [Mandatory Appendix IX](#) shall conform to those of comparable listed components insofar as practicable. In any case, dimensions shall be such as to provide strength and performance equivalent to standard components except as provided in [Chapter IP-3](#).

#### IP-8.1.3 Threads

The dimensions of piping connection threads not otherwise covered by a governing component standard or specification shall conform to the requirements of applicable standards listed in [Table IP-8.1.1-1](#) or [Mandatory Appendix IX](#).

### IP-8.2 RATINGS OF COMPONENTS

#### IP-8.2.1 Listed Components

The pressure–temperature ratings of components listed in [Table IP-8.1.1-1](#) are accepted for pressure design in accordance with [Chapter IP-3](#).

#### IP-8.2.2 Unlisted Components

The pressure–temperature ratings of unlisted piping components shall conform to the applicable provisions of [Chapter IP-3](#).

Thermowell design shall include guidance from ASME PTC 19.3 TW in addition to the requirements stated in this document.

### IP-8.3 REFERENCE DOCUMENTS

The documents listed in [Table IP-8.1.1-1](#) contain references to codes, standards, and specifications not listed in [Table IP-8.1.1-1](#). Such unlisted codes, standards, and specifications shall be used only in the context of the listed documents in which they appear.

The design, materials, fabrication, assembly, examination, inspection, and testing requirements of this Code are not applicable to components manufactured in accordance with the documents listed in [Table IP-8.1.1-1](#), unless specifically stated in this Code or the listed document.

**Table IP-8.1.1-1  
Component Standards**

| Designation                                   | Standard or Specification  |
|---|--|
| <b>Bolting</b>                                |  |
| ASME B18.2.1                                  | Square and Hex Bolts and Screws (Inch Series)  |
| ASME B18.2.2                                  | Square and Hex Nuts (Inch Series)  |
| <b>Metallic Fittings, Valves, and Flanges</b> |  |
| ASME B16.5                                    | Pipe Flanges and Flanged Fittings: NPS ½ Through NPS 24 Metric/Inch Standard                                 |
| ASME B16.9                                    | Factory-Made Wrought Butt-welding Fittings   |
| ASME B16.10                                   | Face-to-Face and End-To-End Dimensions of Valves   |
| ASME B16.11                                   | Forged Fittings, Socket-Welding and Threaded   |
| ASME B16.14                                   | Ferrous Pipe Plugs, Bushings, and Locknuts With Pipe Threads   |
| ASME B16.34                                   | Valves — Flanged, Threaded, and Welding End  |
| ASME B16.36                                   | Orifice Flanges  |
| ASME B16.47                                   | Large Diameter Steel Flanges: NPS 26 Through NPS 60 Metric/Inch Standard                                     |
| ASME B16.50                                   | Wrought Copper and Copper Alloy Braze-Joint Pressure Fittings  |
| MSS SP-42                                     | Class 150 Corrosion Resistant Gate, Globe, Angle and Check Valves With Flanged and Butt Weld Ends            |
| MSS SP-43                                     | Wrought Stainless Steel Butt-Welding Fittings [Note (1)]   |
| MSS SP-51                                     | Class 150LW Corrosion Resistant Cast Flanges and Flanged Fittings  |
| MSS SP-79                                     | Socket-Welding Reducer Inserts   |
| MSS SP-80                                     | Bronze Gate, Globe, Angle and Check Valves   |
| MSS SP-83                                     | Class 3000 Steel Pipe Unions, Socket-Welding and Threaded  |
| MSS SP-97                                     | Integrally Reinforced Forged Branch Outlet Fittings — Socket Welding, Threaded, and Butt-welding Ends        |
| MSS SP-105                                    | Instrument Valves for Code Applications  |
| MSS SP-119                                    | Factory-Made Wrought Belled End Socket-Welding Fittings  |
| MSS SP-134                                    | Valves for Cryogenic Service Including Requirements for Body/Bonnet Extensions                               |
| <b>Metallic Pipe and Tubes [Note (2)]</b>     |  |
| ASME B36.10M                                  | Welded and Seamless Wrought Steel Pipe   |
| ASME B36.19M                                  | Stainless Steel Pipe   |
| API 5B  | Specification for Threading, Gaging and Thread Inspection of Casing, Tubing, and Line Pipe Threads           |
| API 526                                       | Flanged Steel Pressure-Relief Valves   |
| API 594                                       | Check Valves: Flanged, Lug, Wafer and Butt-welding   |
| API 599                                       | Metal Plug Valves — Flanged, Threaded and Welding Ends   |
| API 600                                       | Bolted Bonnet Steel Gate Valves for Petroleum and Natural Gas Industries                                     |
| API 602                                       | Steel Gate, Globe and Check Valves for Sizes DN 100 and Smaller for the Petroleum and Natural Gas Industries |
| API 603                                       | Corrosion-Resistant, Bolted Bonnet Gate Valves — Flanged and Butt-Welding Ends                               |
| API 608                                       | Metal Ball Valves — Flanged, Threaded and Butt-Welding Ends  |
| API 609                                       | Butterfly Valves: Double Flanged, Lug- and Wafer-Type  |
| <b>Miscellaneous</b>                          |  |
| ASME B1.1                                     | Unified Inch Screw Threads (UN and UNR Thread Form)  |
| ASME B1.20.1                                  | Pipe Threads, General Purpose (Inch)   |
| ASME B1.20.7                                  | Hose Coupling Screw Threads (Inch)   |
| ASME B16.20                                   | Metallic Gaskets for Pipe Flanges — Ring-Joint Spiral Wound, and Jacketed                                    |
| ASME B16.21                                   | Nonmetallic Flat Gaskets for Pipe Flanges  |
| ASME B16.25                                   | Butt-welding Ends  |
| ASME B16.48                                   | Steel Line Blanks  |
| ASME B46.1                                    | Surface Texture (Surface Roughness, Waviness, and Lay)   |

GENERAL NOTE: It is not practical to refer to a specific edition of each standard throughout the Code text. Instead, the approved edition references, along with the names and websites of the sponsoring organizations, are shown in [Mandatory Appendix II](#).

**Table IP-8.1.1-1**  
**Component Standards (Cont'd)**

---

NOTES:

- (1) The ratings for MSS SP-43 fittings cannot be calculated based on straight seamless pipe as is done for ASME B16.9 butt welding fittings. See Section 3 of MSS SP-43 for specific pressure-temperature ratings of CR fittings.
- (2) See also [Mandatory Appendix IX](#).



## Chapter IP-9 Fabrication, Erection, and Assembly

### IP-9.1 GENERAL

Hydrogen piping systems shall be constructed in accordance with the requirements of this Chapter and the specified requirements of [Chapters GR-1](#) and [IP-2](#). The requirements apply to all fabrication, erection, and assembly operations or processes, whether performed in a shop or at a construction site.

### IP-9.2 RESPONSIBILITY

See [para. GR-1.2](#).

### IP-9.3 CONTENT AND COVERAGE

The content and coverage of this Chapter, [Chapter GR-1](#), and [Chapter IP-2](#) shall apply in their entirety.

### IP-9.4 PACKAGED EQUIPMENT PIPING

Interconnecting piping is described in [para. GR-1.4](#).

### IP-9.5 EXCLUSIONS

See [para. GR-1.4\(a\)](#).

### IP-9.6 FABRICATION AND ERECTION

Metallic piping materials and components shall be prepared for fabrication and erection by the requirements included in this Chapter and the additional chapters of [Part IP](#), along with the general requirements of [Part GR](#), and mandatory appendices. When required by the engineering design specifications, the nonmandatory appendices shall become mandatory.

#### IP-9.6.1 Welding and Brazing

Welding and brazing shall conform to the requirements described in [para. GR-3.2](#).

#### IP-9.6.2 Welding and Brazing Materials

For welding and brazing materials, see [para. GR-3.3](#).

#### IP-9.6.3 Procedure Qualification Hardness Tests

Hardness testing for welding procedure qualification shall be performed in accordance with the requirements of [para. GR-3.10](#).

#### IP-9.6.3.1 Methods

(a) Hardness testing shall be carried out using either the Vickers HV 10 or HV 5 method in accordance with ASTM E92, or the Rockwell method in accordance with ASTM E18 using the 15N scale.

(b) For aluminum and aluminum alloy materials, hardness testing shall be carried out in accordance with ASTM B648.

(c) The HRC method may only be used for welding procedure qualification if the design stress does not exceed two-thirds of SMYS and the welding procedure specification includes postweld heat treatment.

(d) Other hardness testing methods for welding procedure qualification may be used when specified in the engineering design.

(e) The hardness survey shall be performed at nine different locations. These include three different locations equally spaced (top, middle, bottom) on the weld metal and its corresponding HAZ on each side of the weld. An alternate survey may be used if specified in the engineering design.

**IP-9.6.3.2 Acceptance Criteria.** Hardness testing limits after PWHT shall be per [Table GR-3.10-1](#). Other hardness testing limits shall be based on the material specification and/or the engineering design.

**IP-9.6.3.3 Records.** The hardness data shall be reported on the qualified WPS/PQR.

### IP-9.7 CONSTRUCTION OF WELDMENTS

See [para. GR-3.4](#).

#### IP-9.7.1 Welding Repairs

See [para. GR-3.4.1](#).

#### IP-9.7.2 Cleaning of Pipe Component Surfaces

See [para. GR-3.4.2](#).

#### IP-9.7.3 Joint Preparation and Alignment

See [para. GR-3.4.3](#).

#### IP-9.7.4 Welding of Circumferential Joints

See [para. GR-3.4.4](#).

**IP-9.7.5 Weld End Transition**

See para. GR-3.4.5.

**IP-9.7.6 Weld Reinforcement**

See para. GR-3.4.6.

**IP-9.7.7 Fillet and Socket Welds**

See paras. GR-3.4.7 and IP-5.2.2(b) and (c).

**IP-9.7.8 Seal Welding of Threaded Joints**

See paras. GR-3.4.8 and IP-5.2.2(d).

**IP-9.7.9 Welded Branch Connections**

See para. GR-3.4.9.

**IP-9.7.10 Mitered Joints**

See para. GR-3.4.10.

**IP-9.7.11 Fabricated or Flared Laps**

See para. GR-3.4.11.

**IP-9.8 PREHEATING FOR WELDMENTS**

See para. GR-3.5 and Table GR-3.5.

**IP-9.9 HEAT TREATMENT**

For weldments or bent and formed pipe, see para. GR-3.6.

**IP-9.9.1 PWHT Requirements**

See para. GR-3.6.1 and Table GR-3.6.1-1.

**IP-9.9.2 Governing Thickness**

See para. GR-3.6.2.

**IP-9.9.3 Dissimilar Materials**

See para. GR-3.6.3.

**IP-9.9.4 Methods of Heating**

See para. GR-3.6.4.

**IP-9.9.5 PWHT Heating and Cooling Requirements**

See para. GR-3.6.5.

**IP-9.9.6 Temperature Verification**

See para. GR-3.6.6.

**IP-9.9.7 Delayed Heat Treatment**

See para. GR-3.6.7.

**IP-9.9.8 Partial Heat Treatment**

See para. GR-3.6.8.

**IP-9.10 SPECIFIC AND ALTERNATIVE HEAT TREATMENT REQUIREMENTS**

See para. GR-3.7.

**IP-9.11 CONSTRUCTION OF BRAZEMENTS**

See para. GR-3.8.

**IP-9.12 BENDING AND FORMING OF PIPE AND TUBE**

The requirements of para. GR-3.9 apply, in addition to the following requirements:

(a) *Bending Procedure.* Pipe shall be hot or cold bent in accordance with a written procedure to any radius that will result in surfaces free of cracks and buckles. The procedure shall address at least the following, as applicable:

- (1) material specification and range of size and thickness
- (2) range of bend radii and fiber elongation
- (3) minimum and maximum metal temperature during bending
- (4) method of heating and maximum hold time
- (5) description of bending apparatus and procedure to be used
- (6) mandrels or material and procedure used to fill the bore
- (7) method for protection of thread and machined surfaces
- (8) examination to be performed
- (9) required heat treatment
- (10) postheat treatment dimensional adjustment technique

(b) *Forming Procedure.* Piping components shall be formed in accordance with a written procedure. The temperature range shall be consistent with material characteristics, end use, and specified heat treatment. The thickness after forming shall be not less than required by design. The procedure shall address at least the following, as applicable:

- (1) material specification and range of size and thickness
- (2) maximum fiber elongation expected during forming
- (3) minimum and maximum metal temperature during bending
- (4) method of heating and maximum hold time
- (5) description of forming apparatus and procedure to be used
- (6) materials and procedures used to provide internal support during forming
- (7) examination to be performed

(8) required heat treatment

(c) *Required Heat Treatment.* For bending and forming of pipe and tube, [para. GR-3.9.1](#) applies.

### IP-9.13 ASSEMBLY AND ERECTION

[Chapter IP-6](#) shall apply in its entirety, in addition to the requirements of [paras. IP-9.13.1](#) through [IP-9.18](#).

#### IP-9.13.1 Alignment

(a) *Piping Distortions.* Any distortion of pipe or tube to bring it into alignment for joint assembly that introduces a detrimental strain in equipment or piping components is prohibited.

(b) *Cold Spring.* Before assembling any joints to be cold sprung, guides, supports, and anchors shall be examined for errors that might interfere with desired movement or lead to undesired movement. The gap or overlap of piping prior to assembly shall be checked against the drawing and corrected if the gap varies from the gap specified in the drawing. Heating sufficient to cause plastic deformation of the piping shall not be used to help in closing the gap, because it defeats the purpose of cold springing.

(c) *Flanged Joints.* Before bolting up, flange faces shall be aligned to the design plane within 1 mm in 200 mm ( $\frac{1}{16}$  in./ft) measured across any diameter; flange bolt holes shall be aligned within 3 mm ( $\frac{1}{8}$  in.) maximum offset.

#### IP-9.13.2 Flanged Joints

[Paragraph IP-5.3](#) shall apply in its entirety, in addition to the following requirements:

(a) *Preparation for Assembly.* Any damage to the gasket seating surface that would prevent gasket seating shall be repaired, or the flange shall be replaced.

##### (b) Bolting Torque

(1) In assembling flanged joints, the gasket shall be uniformly compressed to the proper design loading.

(2) Special care shall be used in assembling flanged joints in which the flanges have widely differing mechanical properties. Tightening to a predetermined torque is recommended.

(3) ASME PCC-1 may be used as a guide for assembling flanged joints.

(c) *Bolt Length.* Bolts should extend completely through their nuts. Any bolts that fail to extend completely through their nuts shall be considered acceptably engaged if the lack of complete engagement is not more than one thread.

(d) *Gaskets.* No more than one gasket shall be used between contact faces in assembling a flanged joint.

(e) *Flange Facings.* The flange facing shall be suitable for the intended service and gasket and bolting employed.

### IP-9.14 THREADED JOINTS

[Paragraph IP-5.5](#) shall apply in its entirety, in addition to the following requirements:

(a) *Thread Compound or Lubricant.* Any compound or lubricant used on threads shall be suitable for the service conditions and shall not react with either the service fluid or the piping material.

(b) *Joints for Seal Welding.* A threaded joint to be seal welded shall be made up without thread compound. A joint containing thread compound that leaks during leak testing may be seal welded in accordance with [para. IP-5.5.1\(f\)](#), provided all compound is removed from exposed threads.

(c) *Straight Threaded Joints.* Typical joints using straight threads, with sealing at a surface other than the threads, are shown in [Figure IP-9.14-1](#). Care shall be taken to avoid distorting the seat when incorporating such joints into piping assemblies by welding or brazing.

### IP-9.15 TUBING JOINTS

[Paragraph IP-5.5.3](#) shall apply in its entirety, in addition to the following requirements:

(a) *Flared Tubing Joints.* The sealing surface of the flare shall be examined for imperfections before assembly, and any flare having imperfections shall be rejected.

(b) *Flareless and Compression Tubing Joints.* Where the manufacturer's instructions call for a specified number of turns of the nut, these shall be counted from the point at which the nut becomes finger tight.

### IP-9.16 EXPANDED JOINTS AND SPECIAL JOINTS

[Paragraph IP-5.8](#) shall apply in its entirety, in addition to the following requirements: Expanded and special joints (as defined in [para. IP-5.8](#)) shall be installed and assembled in accordance with the manufacturer's instructions. The manufacturer's instructions shall be permitted to be modified by the engineering design. Joint members shall be adequately engaged.

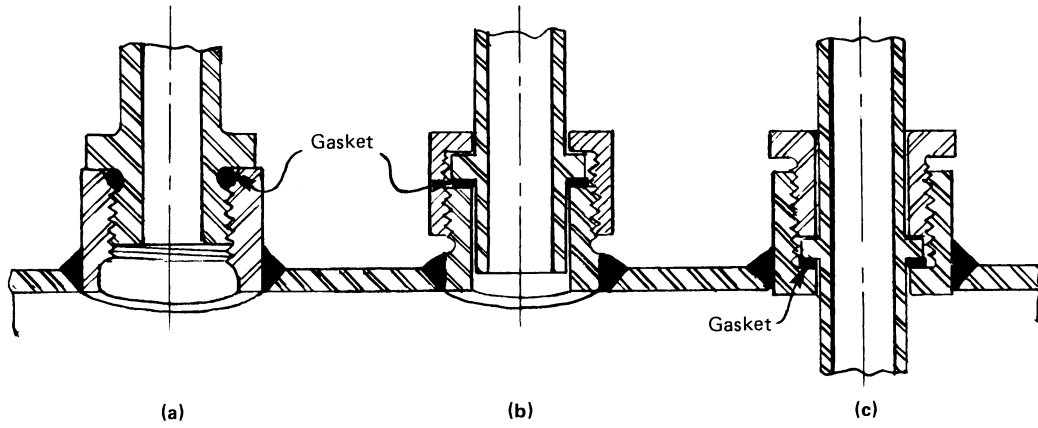
### IP-9.17 PIPE ATTACHMENTS AND SUPPORTS

See [paras. GR-3.4.12](#) and [GR-3.4.13](#), and [Chapter IP-6](#).

### IP-9.18 CLEANING OF PIPING

See [Nonmandatory Appendix A](#).

**Figure IP-9.14-1**  
**Typical Threaded Joints Using Straight Threads**



GENERAL NOTE: Threads are ASME B1.1 straight threads.

# Chapter IP-10

## Inspection, Examination, and Testing

### IP-10.1 SCOPE

This Chapter includes the requirements for inspections by owner, quality control examinations, NDE, and specified tests by the construction organization. Inspection, examination, and testing shall be in compliance with the requirements of [Chapters GR-4](#) and [GR-6](#), as well as the applicable specific requirements in this Chapter and the engineering design.

### IP-10.2 RESPONSIBILITY

Refer to [para. GR-4.2.1](#) for the owner's responsibility. The construction organization shall be responsible for all examinations applying to quality control functions and NDE. See [para. GR-4.3.1](#).

### IP-10.3 INSPECTIONS BY OWNER'S INSPECTOR

Inspections by owner's Inspector include inspections, verifications, and audits of the construction of piping systems, which include fabrication, welding, heat treatment, assembly, erection, examination, and testing, in addition to the construction organization's documented procedures, personnel qualifications, and quality control records. See [para. GR-4.2](#).

### IP-10.4 EXAMINATION REQUIREMENTS

Prior to initial operation, each piping installation, including components and workmanship, shall be examined in accordance with the requirements of this paragraph. Any additional NDE required by engineering design, and the acceptance criteria to be applied, shall be specified.

(a) For base metal groupings of P- and S-Nos. 3, 4, 5A, 5B, and 5C materials, final NDE shall be performed after completion of any heat treatment.

(b) For a welded branch connection, the examination of, and any necessary repairs to, the pressure-containing weld shall be completed before any reinforcing pad or saddle is added.

(c) [Paragraph GR-4.4](#) applies to personnel qualification.

(d) [Paragraph GR-4.7](#) applies to supplementary examination.

(e) [Paragraph GR-4.8](#) applies to examinations to resolve uncertainty.

(f) [Paragraph GR-4.11](#) applies to examination records. In addition, the examiner shall provide the Inspector with a certification that all the quality control requirements of the Code and of the engineering design have been carried out.

#### IP-10.4.1 Quality Control Examinations

Quality control examination extent, acceptance criteria, and methods shall be in accordance with the Quality System Program described in [Chapter GR-6](#).

#### IP-10.4.2 Extent of Required NDE

(23)

Piping systems, components, weldments, or braze-ments shall be examined to the extent specified in [paras. IP-10.4.2.1](#) and [IP-10.4.2.2](#) and to any greater extent specified in the engineering design. This Part differentiates extent of examination for lower pressure piping based on the location of the piping. A "ventilated location" is a location where leaking hydrogen cannot reach a concentration of 4% by volume in air.

**IP-10.4.2.1 Visual Examination.** At least the following shall be visually examined in accordance with [para. IP-10.4.5.2](#): (23)

(a) sufficient materials and components, selected at random, to satisfy the examiner that they conform to specifications and are free from defects.

(b) at least 5% of fabrication, as defined in [section GR-1.5](#).

(c) 100% of all completed welds, except those in components made in accordance with a listed standard.

(d) assembly of threaded, bolted, and other joints, at random, to satisfy the examiner that they conform to the applicable requirements of [Chapter IP-9](#). When pneumatic testing is to be performed, all threaded, bolted, and other mechanical joints shall be examined.

(e) alignment, supports, and cold spring, at random, during erection of piping.

(f) erected piping, at random, for evidence of defects that would require repair or replacement, and for other evident deviations from the intent of the design.

(g) brazed joints, at random, following cleaning of braze deposit and affected base metal.

**IP-10.4.2.2 Other Examination.** [Table IP-10.4.2.2-1](#) describes other than visual examination. (23)

**Table IP-10.4.2.2-1  
Required Nondestructive Examinations Other Than VT**

(23)

| <b>Joint Type</b>                          | <b>Design Conditions up to Class 150 in Ventilated Location</b> | <b>Design Conditions up to Class 150 Not in Ventilated Location</b> | <b>Design Conditions Above Class 150</b>                         |
|--|---|---|--|
| Girth and miter groove welds<br>[Note (1)] | 5% random hardness testing<br>[Note (2)]                        | 5% random RT or UT<br>5% random hardness testing<br>[Note (2)]      | 10% random RT or UT<br>20% random hardness testing<br>[Note (2)] |
| Longitudinal groove welds                  | 5% random RT or UT<br>5% random hardness testing<br>[Note (2)]  | 5% random RT or UT<br>5% random hardness testing<br>[Note (2)]      | 10% random RT or UT<br>20% random hardness testing<br>[Note (2)] |
| Fillet welds                               | 10% random PT or MT<br>5% random hardness testing<br>[Note (2)] | 10% random PT or MT<br>5% random hardness testing<br>[Note (2)]     | 20% random PT or MT<br>20% random hardness testing<br>[Note (2)] |

## NOTES:

- (1) Girth and miter groove welds include other complete joint penetration weldments such as for branch connections and fabricated laps. When it is impractical to RT or UT complete joint penetration branch connection weldments due to inaccessibility, such welds shall be examined by MT or PT, along with the required VT.
- (2) Hardness testing is only required for those materials with acceptance criteria described in [Table IP-10.4.3-2](#).

**IP-10.4.3 Acceptance Criteria**

(a) *Acceptance Criteria for Welds.* Weld imperfections shall be limited as specified in [Table IP-10.4.3-1](#), and weldment hardness shall be limited as specified in [Table IP-10.4.3-2](#). (See [Table IP-10.4.3-3](#) for letter symbols used in [Table IP-10.4.3-1](#).)

(b) *Acceptance Criteria for Brazed Joints.* The following are unacceptable for brazed joints:

- (1) cracks
- (2) lack of fill
- (3) voids in brazed deposit
- (4) porosity in brazed deposit
- (5) flux entrapment
- (6) noncontinuous fill
- (7) base metal dilution into brazed deposit
- (8) unsatisfactory surface appearance of the brazed deposit and base metal, caused by overheating resulting in porous and oxidized surfaces

**IP-10.4.4 Procedures**

Any examination shall be performed in accordance with a written procedure that conforms to one of the methods specified in [para. IP-10.4.5](#), including special methods [see [para. IP-10.4.5.1\(b\)](#)]. Procedures shall be written as required in ASME BPVC, Section V, Article 1, T-150. The employer shall certify records of the examination procedures employed, showing dates and results of procedure qualifications, and shall maintain them and make them available to the Inspector.

**IP-10.4.5 Types of Examination****IP-10.4.5.1 General**

(a) *Methods.* Except as provided in (b), any examination required by this Code, by the engineering design, or by the Inspector shall be performed in accordance with one of the methods specified herein.

(b) *Special Methods.* If a method not specified herein is to be used, it and its acceptance criteria shall be specified in the engineering design in enough detail to permit qualification of the necessary procedures and examiners.

**IP-10.4.5.2 Visual Examination (VT).** Visual examination shall be performed in accordance with ASME BPVC, Section V, Article 9. (23)

**IP-10.4.5.3 Radiographic Examination (RT).** Examinations for weldments and components shall be performed in accordance with ASME BPVC, Section V, Article 2, referencing ASTM E390 for steel fusion welds and ASTM E1648 for aluminum fusion welds.

**IP-10.4.5.4 Liquid Penetrant (PT).** Liquid penetrant examination for weldments and components shall be performed in accordance with ASME BPVC, Section V, Article 6.

**IP-10.4.5.5 Magnetic Particle (MT).** Magnetic particle examination for weldments and components shall be performed in accordance with ASME BPVC, Section V, Article 7.

**IP-10.4.5.6 Ultrasonic Examination (UT)**

(a) UT shall be performed in accordance with ASME BPVC, Section V Article 5, except that the following alternative is permitted for basic calibration blocks specified in

**Table IP-10.4.3-1  
Acceptance Criteria for Weldments and Methods for Evaluating Weld Imperfections**

| Piping Design  |                      |        |  |                      |        |                                   |                      |        |  |                    |                             |  |
|--|----------------------|--------|--|----------------------|--------|-----------------------------------|----------------------|--------|--|--------------------|-----------------------------|--|
| Design Conditions up to Class 150 in a Ventilated Location |                      |        | Design Conditions up to Class 150 Not in a Ventilated Location |                      |        | Design Conditions Above Class 150 |                      |        | Weld Imperfection [Note (1)]                                 | Examination Method |                             |  |
| Type of Weld   |                      |        | Type of Weld   |                      |        | Type of Weld                      |                      |        |  | Visual             | Radio-graphy and Ultrasonic | Magnetic Particle and Liquid Penetrant |
| Girth and Miter Groove                                     | Longitudi-nal Groove | Fillet | Girth and Miter Groove   | Longitudi-nal Groove | Fillet | Girth and Miter Groove            | Longitudi-nal Groove | Fillet |  |                    |                             |  |
| A  | A                    | A      | A  | A                    | A      | A                                 | A                    | A      | Cracks   | ✓                  | ✓                           | ✓                                      |
| B  | B                    | B      | B  | B                    | B      | B                                 | B                    | B      | Lack of fusion and incomplete penetration                    | ✓                  | ✓                           | ✓                                      |
| C  | C                    | C      | C  | C                    | C      | C                                 | C                    | C      | Surface porosity; inclusions, tungsten                       | ✓                  | ✓                           | ✓                                      |
| D  | D                    | N/A    | D  | D                    | N/A    | D                                 | D                    | N/A    | Internal porosity  | ...                | ✓                           | ...                                    |
| F  | F                    | N/A    | F  | F                    | N/A    | E                                 | E                    | N/A    | Internal inclusions, slag or tungsten; elongated indications | ...                | ✓                           | ...                                    |
| H  | H                    | H      | H  | H                    | H      | G                                 | G                    | G      | Depth of undercut  | ✓                  | ✓                           | ...                                    |
| J  | J                    | N/A    | J  | J                    | N/A    | I                                 | I                    | N/A    | Depth of surface concavity                                   | ✓                  | ✓                           | ...                                    |
| K  | K                    | K      | K  | K                    | K      | K                                 | K                    | K      | Weld surface finish O.D. and I.D.                            | ✓                  | ✓                           | ...                                    |
| L  | L                    | L      | L  | L                    | L      | L                                 | L                    | L      | Weld reinforcement O.D. and I.D.                             | ✓                  | ✓                           | ...                                    |

GENERAL NOTES:

- (a) Girth and miter groove welds include other complete joint penetration weldments such as for branch connections and fabricated laps.
- (b) Fillet welds include socket and seal welds, and attachment welds for slip-on flanges, branch reinforcement, and supports.
- (c) Weld imperfections are evaluated by one or more of the types of examination methods given, as specified in [para. IP-10.4](#), or by the engineering design.
- (d) "N/A" indicates the Code does not establish acceptance criteria or does not require evaluation of this kind of imperfection for this type of weld. See [Table IP-10.4.3-3](#) for letter symbols.
- (e) Check (✓) indicates examination method generally used for evaluating this kind of weld imperfection.
- (f) Ellipsis ( ... ) indicates examination method not generally used for evaluating this kind of weld imperfection.
- (g) Criteria given are for required examination method(s). More stringent criteria may be specified in the engineering design.
- (h) Longitudinal groove welds (single or double) include straight seam only. Criteria are not intended to apply to welds made in accordance with a standard listed in [Table IP-8.1.1-1](#) or [Mandatory Appendix IX, Table IX-1A](#).

NOTE: (1) The criteria value for the type of weld and design pressure is identified by the letter symbol for the measure and acceptable value limits of each NDE method.



**Table IP-10.4.3-2**  
**Hardness Testing Acceptance Criteria for Weldments**

| Base Metal<br>P-No. [Note (1)] | Base Metal Group                          | Maximum<br>Brinell<br>Hardness | Vickers HV<br>Maximum<br>Hardness | Rockwell 15N<br>Maximum<br>Hardness |
|--------------------------------|---|--------------------------------|-----------------------------------|-------------------------------------|
| 1                              | Carbon steel                              | 200                            | 200                               | 67                                  |
| 3                              | Alloy steels, Cr $\leq$ 1/2%              | 225                            | 225                               | 69                                  |
| 4                              | Alloy steels, 1/2% < Cr $\leq$ 2%         | 225                            | 225                               | 69                                  |
| 5A, 5B                         | Alloy steels, 2 1/4% $\leq$ Cr $\leq$ 10% | 241                            | 241                               | 71                                  |

NOTE: (1) P-Number from ASME BPVC, Section IX, QW/QB-422.

**Table IP-10.4.3-3**  
**Criterion Value Notes for Table IP-10.4.3-1**

| Symbol | Criterion Measure  | Acceptable Value Limits [Note (1)]  |
|--------|--|---|
| A      | Cracks   | None of weld deposit, HAZ and BM  |
| B      | Lack of fusion and incomplete penetration  | None of weld deposit or weld deposit to BM  |
| C      | Surface porosity; inclusions, slag or tungsten   | None of weld deposit  |
| D      | Size and distribution of internal porosity   | See ASME BPVC, Section VIII, Division 1, Mandatory Appendix 4   |
| E      | Internal inclusions, slag or tungsten; elongated indications<br>Individual length<br>Individual width<br>Cumulative length | $\leq \bar{T}_w / 4$ and $\leq 4$ mm ( $^{5}/_{32}$ in.)<br>$\leq \bar{T}_w / 4$ and $\leq 2.5$ mm ( $^{3}/_{32}$ in.)<br>$\leq \bar{T}_w$ in any $12\bar{T}_w$ weld length |
| F      | Internal inclusions, slag or tungsten; elongated indications<br>Individual length<br>Individual width<br>Cumulative length | $\leq \bar{T}_w / 3$<br>$\leq 2.5$ mm ( $^{3}/_{32}$ in.) and $\leq \bar{T}_w / 3$<br>$\leq \bar{T}_w$ in any $\bar{T}_w$ weld length                                       |
| G      | Depth of undercut  | None allowed  |
| H      | Depth of undercut [Note (2)]   | $\leq 1$ mm ( $^{1}/_{32}$ in.) and $\leq \bar{T}_w / 4$  |
| I      | Depth of root surface concavity  | None below pipe component I.D.  |
| J      | Depth of root surface concavity [Note (3)]   | Total joint thickness, including weld reinforcement, $\geq \bar{T}_w$   |
| K      | Weld surface of O.D. finish [Note (4)]   | Roughness average $\leq 12.5$ $\mu$ m $R_a$ (500 $\mu$ in. $R_a$ ) per ASME B46.1   |
| L      | Weld reinforcement O.D. and I.D. [Note (5)]  | See Table GR-3.4.6-1  |

NOTES:

- (1) Where two limiting values are separated by "and," the lesser of the values determines acceptance.  $\bar{T}_w$  is the nominal wall thickness of the thinner of two components joined by a butt weld.
- (2) Depth of undercut shall be applied to the O.D. and I.D. surfaces.
- (3) Concavity on the root side of a single groove weld is permitted when the resulting thickness of the weld is at least equal to the thickness of the thinner member of the two sections being joined and the contour of the concavity is smooth without sharp edges.
- (4) Weld metal reinforcement, O.D. and I.D., shall merge smoothly into the weld surfaces.
- (5) For all butt groove welds (single and double), height is the lesser of the measurements made from the surfaces of the adjacent components. For single groove welds, I.D. reinforcement (internal protrusion) is included in a weld (see Figure GR-3.4.4-1). Weld reinforcement, O.D. or I.D., may be flush to the adjoining surfaces. For fillet welds and added reinforcement to nonbutt groove welds, height is measured from the theoretical throat (see Figure GR-3.4.7-1). Internal protrusion does not apply.

T-542.2.1 and T-542.8.1.1 (reference ASTM E164): When the basic calibration blocks have not received heat treatment in accordance with T-542.1.1(c) and T-542.8.1.1, transfer methods shall be used to correlate the responses from the basic calibration block and the component. Transfer is accomplished by noting the difference between responses received from the same reference reflector in the basic calibration block and in the component, and correcting for the difference. The reference reflector may be a V-notch (which must subsequently be removed), an angle beam search unit acting as a reflector, or any other reflector that will aid in accomplishing the transfer. When the transfer method is chosen as an alternative, it shall be used with the following minimum requirements:

(1) For sizes < DN 50 (NPS 2), use once in each ten welded joints examined.

(2) For sizes > DN 50 (NPS 2) and < DN 450 (NPS 18), use once in each 1.5 m (5 ft) of welding examined.

(3) For sizes > DN 450 (NPS 18), use once for each welded joint examined.

(4) Each type of material, and each size and wall thickness, shall be considered separately in applying the transfer method. In addition, the transfer method shall be used at least twice on each type of weld joint.

(5) The reference level for monitoring discontinuities shall be modified to reflect the transfer correction when the transfer method is used.

(6) A linear-type discontinuity is unacceptable if the amplitude of the indication exceeds the reference level and its length exceeds 6 mm ( $\frac{1}{4}$  in.) for  $T_w \leq 19$  mm ( $\frac{3}{4}$  in.),  $T_w/3$  for  $19$  mm ( $\frac{3}{4}$  in.) <  $T_w \leq 57$  mm ( $2\frac{1}{4}$  in.), or 19 mm ( $\frac{3}{4}$  in.) for  $T_w > 57$  mm ( $2\frac{1}{4}$  in.).

(b) For ultrasonic examination of longitudinal welds, the following requirements shall be met:

(1) A calibration (reference) standard shall be prepared from a representative sample. Longitudinal (axial) reference notches shall be introduced on the outer and inner surfaces of the standard, in accordance with Figure 2(c) of ASTM E213-20, to a depth not greater than the larger of 0.1 mm (0.004 in.) or 4% of specimen thickness and a length not more than 10 times the notch depth.

(2) The pipe or tubing shall be scanned in both circumferential directions in accordance with Supplementary Requirement S1 of ASTM E213-20. Removal of external weld reinforcement of welded pipe may be necessary prior to this examination.

(3) Any indication greater than that produced by the calibration notch represents a defect; defective pipe and tubing shall be rejected.

(23) **IP-10.4.5.7 Hardness Control and Testing.** Hardness testing for production weldments shall be as follows:

(a) Hardness readings shall be taken with a portable hardness tester in accordance with ASTM A833 or ASTM E110. Other hardness testing techniques may be applied when specified by the engineering design.

(b) Hardness testing survey of circumferential weldments shall be performed as follows:

(1) For piping  $\leq$  DN 150 (NPS 6), one test is required per weld.

(2) For piping > DN 150 (NPS 6) but  $\leq$  DN 300 (NPS 12), two tests are required per weld.

(3) For piping > DN 300 (NPS 12), three tests are required per weld.

(4) Tests at multiple locations on a weld shall be equally spaced. The tests shall include weld metal and its corresponding HAZ on each side of the weld.

(5) Longitudinal welds require testing at one location in 20 ft of weldments; multiple location testing shall be at equally spaced intervals. The tests shall include weld metal and its corresponding HAZ on each side of the weld.

(c) Non-PWHT (as-welded condition) hardness testing shall be conducted of the following:

(1) base metal Group P-1, carbon steel weldments made using SAW or FCAW process. The hardness testing method, area of survey, and acceptance limits shall be specified by the engineering design.

(2) weldments containing carbon steel filler metal with a minimum of 1.6% Mn. The hardness testing method, area of survey, and acceptance limits shall be specified by the engineering design.

(d) Production weldments that do not meet the hardness test requirements (hard welds) shall be removed and replaced. The use of additional heat treatment that may correct the hardness of the weldment requires a supporting WPS/PQR with approval of the engineering design.

## IP-10.5 TESTING

### IP-10.5.1 Required Leak Tests

Prior to initial operation, and after completion of the applicable examinations and repairs required by [para. IP-10.4](#), each piping system shall be tested to ensure tightness. Visual observation shall be made of a hydrostatic leak test performed in accordance with ASME BPVC, Section V, Article 10 and [para. IP-10.6](#), except as provided herein.

(a) Where the owner or the engineering design considers hydrostatic leak testing impracticable, either a pneumatic test in accordance with [para. IP-10.7](#) or a combined hydrostatic-pneumatic test in accordance with [para. IP-10.8](#) may be substituted, recognizing the hazard of energy stored in compressed gas.

(b) Where the owner or the engineering design considers both hydrostatic and pneumatic leak testing impracticable, the alternative specified in [para.](#)

IP-10.10 may be used. A sensitive leak test in accordance with para. IP-10.9 is also required.

### IP-10.5.2 Requirements

The requirements in (a) through (f) apply to more than one type of leak test.

#### (a) Limitations on Pressure

(1) *Stress Exceeding Yield Strength.* If the test pressure would produce a nominal pressure stress or longitudinal stress in excess of yield strength at test temperature, the test pressure may be reduced to the maximum pressure that will not exceed the yield strength at test temperature (see para. IP-2.2.7).

(2) *Test Fluid Expansion.* If a pressure test is to be maintained for a period of time and the test fluid in the system is subject to thermal expansion, precautions shall be taken to avoid excessive pressure.

(3) *Preliminary Pneumatic Test.* A preliminary test using air at no more than 170 kPa (25 psi) gage pressure may be made prior to hydrostatic testing to locate major leaks.

#### (b) Other Test Requirements

(1) *Examination for Leaks.* A leak test shall be maintained for at least 10 min, and all joints and connections shall be examined for leaks.

(2) *Heat Treatment.* Leak tests shall be conducted after any heat treatment has been completed.

(3) *Low Test Temperature.* The possibility of brittle fracture shall be considered when conducting leak tests at metal temperatures near the ductile-brittle transition temperature.

#### (c) Special Provisions for Testing

(1) *Piping Components and Subassemblies.* Piping components and subassemblies may be tested either separately or as assembled piping.

(2) *Flanged Joints.* Flanged joints used to connect piping components and subassemblies that have previously been tested, and flanged joints at which a blank or blind is used to isolate equipment or other piping during a test, need not be leak tested in accordance with para. IP-10.5.1.

(3) *Closure Welds.* The final weld connecting piping systems or components that have been successfully tested in accordance with para. IP-10.5 need not be leak tested, provided the weld is subjected to in-process examination and passes with 100% radiographic examination in accordance with para. IP-10.4.5.3 or 100% ultrasonic examination in accordance with para. IP-10.4.5.6.

(d) *Externally Pressured Piping.* Piping subject to external pressure shall be tested at an internal gage pressure 1.5 times the external differential pressure but not less than 105 kPa (15 psi).

#### (e) Jacketed Piping

(1) The internal line shall be leak tested on the basis of the internal or external design pressure, whichever is more critical. This test must be performed before the

jacket is completed if it is necessary to provide visual access to joints of the internal line as required by para. IP-10.5.3(a).

(2) The jacket shall be leak tested in accordance with para. IP-10.5.1 on the basis of the jacket design pressure unless otherwise specified in the engineering design.

(f) *Repairs or Additions After Leak Testing.* If repairs or additions are made following the leak test, the affected piping shall be retested, except that for minor repairs or additions, the owner may waive retest requirements when precautionary measures are taken to ensure sound construction.

### IP-10.5.3 Preparation for Leak Test

(a) *Joints Exposed.* All joints, welds (including structural attachment welds to pressure-containing components), and bonds shall be left uninsulated and exposed for examination during leak testing, except that joints previously tested in accordance with this Code may be insulated or covered. All joints may be primed and painted prior to leak testing unless a sensitive leak test (see para. IP-10.9) is required.

(b) *Temporary Supports.* Piping designed for vapor or gas shall be provided with additional temporary supports, if necessary, to support the weight of test liquid.

#### (c) Piping With Expansion Joints

(1) An expansion joint that depends on external main anchors to restrain pressure end load shall be tested in place in the piping system.

(2) A self-restrained expansion joint previously shop tested by the manufacturer [see ASME B31.3 Appendix X, para. X302.2.3(a)] may be excluded from the system under test, except that such expansion joints shall be installed in the system when a sensitive leak test in accordance with para. IP-10.9 is required.

(3) A piping system containing expansion joints shall be leak tested without temporary joint or anchor restraint at the lesser of 150% of design pressure for a bellows-type expansion joint or the system test pressure determined in accordance with para. IP-10.5. In no case shall a bellows-type expansion joint be subjected to a test pressure greater than the manufacturer's test pressure.

(d) When a system leak test at a pressure greater than the minimum test pressure specified in (c) above or greater than 150% of the design pressure within the limitations of para. IP-10.5.2(a)(1) is required, bellows-type expansion joints shall be removed from the piping system or temporary restraints shall be added to limit main anchor loads if necessary.

### IP-10.5.4 Limits of Tested Piping

Equipment that will not be tested shall be either disconnected from the piping or isolated by blinds or other means during the test. A valve may be used, provided

the valve (including its closure mechanism) is suitable for the test pressure.

## IP-10.6 HYDROSTATIC LEAK TEST

### IP-10.6.1 Test Fluid

The fluid shall be water unless there is the possibility of damage due to freezing or to adverse effects of water on the piping or the process (see [Nonmandatory Appendix B](#)). In that case, another suitable nontoxic liquid may be used. If the liquid is flammable, its flash point shall be at least 49°C (120°F), and consideration shall be given to the test environment.

### IP-10.6.2 Test Pressure

Except as provided in [para. IP-10.6.3](#), the hydrostatic test pressure at any point in a metallic piping system shall be as follows:

(a) not less than 1.5 times the design pressure

(b) when the design temperature is greater than the test temperature, the minimum test pressure at the point under consideration shall be calculated by [eq. \(24\)](#). When the piping system contains more than one material or more than one design temperature, [eq. \(24\)](#) shall be used for every combination, excluding pipe supporting elements and bolting, and the maximum calculated value of  $P_T$  is the minimum test gage pressure.

$$P_T = 1.5PR_r \quad (24)$$

where

$P$  = internal design gage pressure

$P_T$  = minimum test gage pressure

$R_r$  = ratio of  $S_T/S$  for components without established ratings, but shall not exceed 6.5

= ratio of the component pressure rating at the test temperature to the component pressure rating at component design temperature for components with established ratings, but shall not exceed 6.5

$S$  = stress value at design temperature (see [Mandatory Appendix IX, Table IX-1A](#))

$S_T$  = stress value at test temperature

Alternatively, for carbon steel piping with a minimum specified yield strength not greater than 290 MPa (42 ksi), the test pressure for the assembly of components, excluding pipe supporting elements and bolting, may be based on  $R_r$  for any of the components in the assembly.

(c) If the test pressure as defined above would produce a nominal pressure stress or longitudinal stress in excess of the yield strength at test temperature, the test pressure may be reduced to the maximum pressure that will not exceed the yield strength at test temperature [see [paras. IP-2.2.7\(c\)](#) and [\(d\)](#)]. For metallic bellows expansion joints, see ASME B31.3, Appendix X, [para. X302.2.3\(a\)](#).

### IP-10.6.3 Hydrostatic Test of Piping With Vessels as a System

(a) When the test pressure of piping attached to a vessel is the same as or less than the test pressure for the vessel, the piping may be tested with the vessel at the piping test pressure.

(b) When the test pressure of the piping exceeds the vessel test pressure and it is not considered practicable to isolate the piping from the vessel, the piping and vessel may be tested together at the vessel test pressure, provided the owner approves and the vessel test pressure is not less than 77% of the piping test pressure calculated in accordance with [para. IP-10.6.2\(b\)](#).

(c) The provisions of [para. IP-10.6.3](#) do not affect the pressure test requirements of any applicable vessel code.

## IP-10.7 PNEUMATIC LEAK TEST

### IP-10.7.1 Precautions

Pneumatic testing involves the hazard of released energy stored in compressed gas. Particular care must therefore be taken to minimize the chance of brittle failure during a pneumatic leak test. Test temperature is important in this regard and must be considered when the designer chooses the material of construction. See [para. IP-10.5.2\(b\)\(3\)](#) and [Nonmandatory Appendix B](#).

### IP-10.7.2 Pressure Relief Device

(23)

A pressure relief device shall be provided, having a set pressure not higher than 110% of the test pressure, except that for test pressures lower than 700 kPa (100 psi), the set pressure may be as high as 70 kPa (10 psi) above the test pressure but not higher than 1.5 times the rating of the weakest components in the system.

### IP-10.7.3 Test Fluid

The gas used as test fluid, if not air, shall be nonflammable and nontoxic.

### IP-10.7.4 Test Pressure

The test pressure shall be not less than 1.1 times the design pressure and shall not exceed the lesser of the following:

(a) 1.33 times the design pressure

(b) the pressure that would produce a nominal pressure stress or longitudinal stress in excess of 90% of the yield strength of any component at the test temperature

### IP-10.7.5 Procedure

The pressure shall be gradually increased until a gage pressure, which is the lesser of one-half the test pressure or 170 kPa (25 psi), is attained, at which time a preliminary check shall be made, including examination of joints in

accordance with [para. IP-10.4.5.2](#). Thereafter, the pressure shall be gradually increased in steps until the test pressure is reached, holding the pressure at each step long enough to equalize piping strains. The pressure shall then be reduced to the design pressure before examining for leakage in accordance with [para. IP-10.5.2\(b\)\(1\)](#).

### IP-10.8 HYDROSTATIC-PNEUMATIC LEAK TEST

If a combination hydrostatic-pneumatic leak test is used, the requirements of [para. IP-10.7](#) shall be met, and the pressure in the liquid-filled part of the piping shall not exceed the limits stated in [para. IP-10.6](#).

### IP-10.9 SENSITIVE LEAK TEST

The test shall be in accordance with the Gas and Bubble Test method specified in ASME BPVC, Section V, Article 10, or by another method demonstrated to have equal sensitivity. Sensitivity of the test shall be not less than  $10^{-3}$  atm · mL/s under test conditions. The test pressure shall be at least the lesser of 105 kPa (15 psi) gage or 25% of the design pressure. The pressure shall be gradually increased until a gage pressure the lesser of one-half the test pressure or 170 kPa (25 psi) is attained, at which time a preliminary check shall be made. Then the pressure shall be gradually increased in steps until the test pressure is reached, the pressure being held long enough at each step to equalize piping strains.

### IP-10.10 ALTERNATIVE LEAK TEST

The following procedures and leak test method may be used only under the conditions stated in [para. IP-10.5.1\(b\)](#).

#### IP-10.10.1 Examination of Welds

Welds, including those used in the manufacture of welded pipe and fittings, which have not been subjected to hydrostatic or pneumatic leak tests in accordance with this Code, shall be examined as follows:

(a) Circumferential and longitudinal groove welds with complete weld joint penetration shall be examined by the required NDE method in addition to the visual examination, in accordance with [para. IP-10.4](#), [Table IP-10.4.3-1](#), and [Table IP-10.4.3-3](#).

(b) All welds, including structural attachment welds, not covered in (a) above, shall be examined using the liquid penetrant method in [para. IP-10.4.5.4](#) or, for magnetic materials, the magnetic particle method in [para. IP-10.4.5.5](#).

### IP-10.10.2 Flexibility Analysis

A flexibility analysis of the piping system shall have been made in accordance with the requirements of ASME B31.3, [para. 319.4.2\(b\)](#), if applicable, or (c) and (d).

### IP-10.10.3 Test Method

The system shall be subjected to a sensitive leak test in accordance with [para. IP-10.9](#).

### IP-10.11 MECHANICAL AND METALLURGICAL TESTING

When required by design, material specifications, and qualifications for welding and brazing, one or more of the tests may be required, in addition to the test required for the construction of the piping system.

(a) *Mechanical Tests (Tensile, Charpy Impact, and Bend)*. Destructive testing of the materials, components, welding materials, and welding and brazing test samples, for procedure qualification, shall be conducted per the material specification, the engineering design, applicable parts of this Code, and the ASME or ASTM testing standards.

(b) *Metallurgical Tests (Chemistry)*. Testing conducted of the materials and components, along with the test samples for the qualification of welding materials and procedures for welding and brazing, shall be conducted per the material specification, the engineering design, applicable parts of this Code, and the ASME or ASTM testing standards.

(c) *Ferrite Tests*

### IP-10.12 RECORDS OF TESTING

The records include the construction organization's documentation of the testing and quality control processes.

(a) *Responsibility*. It is the responsibility of the construction organization (piping design manufacturer, fabricator, and erector), as applicable, to prepare the records required by the construction organization's QSP and documented procedures, along with the applicable parts of this Code, the engineering design, and the applicable requirements of ASME or ASTM standards for the specific testing methods.

(b) *Retention of Records*. Unless otherwise specified by the engineering design, owner, or jurisdiction, the specified records shall be retained for at least 5 yr after the record is generated for the project.

# PART PL PIPELINES

---

## Chapter PL-1 Scope and Exclusions

### PL-1.1 SCOPE

Rules for this Part of the Code apply to transmission pipelines, distribution pipelines, and service lines used for transporting hydrogen from a production facility to the point of final use.

### PL-1.2 CONTENT AND COVERAGE

This Part sets forth requirements for materials, components, design, fabrication, assembly, erection, inspection, examination, testing, operation, and maintenance of hydrogen pipelines.

(a) design and manufacture of pressure vessels covered by the ASME BPVC

(b) pipeline systems with temperatures above 232°C (450°F) or below -62°C (-80°F)

(c) pipeline systems with pressures above 21 MPa (3,000 psig)

(d) pipeline systems with a moisture content greater than 20 ppm [dew point at 1 atm = -55°C (-67°F)]

(e) pipeline systems designed to ASME B31.8 with hydrogen-containing gas mixtures that have been demonstrated by engineering analysis or successful experience to not adversely affect the integrity of the pipeline systems

### (23) PL-1.3 EXCLUSIONS

This Part excludes the following:



## Chapter PL-2

# Pipeline Systems Components and Fabrication Details

### PL-2.1 PURPOSE

The purpose of this Chapter is to provide requirements for hydrogen pipeline systems covering

(a) specifications for, and selection of, all items and accessories that are a part of the pipeline system, other than the pipe itself

(b) acceptable methods of making branch connections

(c) provisions to address the effects of temperature changes

(d) methods for support and anchorage of exposed and buried pipeline systems

### PL-2.2 PIPING SYSTEM COMPONENTS

All components of pipeline systems, including valves, flanges, fittings, headers, special assemblies, etc., shall be designed in accordance with the requirements of this section and recognized good engineering practices to withstand operating pressures and other specified loadings. Components shall be designed to withstand the specified field test pressure without failure, impairment of their serviceability, or leakage detectable by the test procedure.

#### PL-2.2.1 Unlisted Components

Components not listed in [Mandatory Appendix II](#), but which conform to a published specification or standard, may be used within the following limitations:

(a) The designer shall be satisfied that composition, mechanical properties, method of manufacture, and quality control are comparable to the corresponding characteristics of listed components.

(b) Pressure design shall be verified in accordance with [para. PL-3.7.1](#).

#### PL-2.2.2 Valves and Pressure-Reducing Devices

(a) Valves shall conform to standards and specifications referenced in this Code and shall be used only in accordance with the service recommendations of the manufacturer.

(1) Valves manufactured in accordance with the following standards may be used:

(-a) ASME B16.34

(-b) ASME B16.38

(-c) API 6D

(-d) API 609

(-e) API 600

(-f) API 602

(2) Valves having shell (body, bonnet, cover, and/or end flange) components made of cast or ductile iron shall not be used in hydrogen service.

(3) Pipeline valves purchased to API 6D requirements shall be capable of passing the pressure tests described in API 6D Annex C, para. C4, using helium as the test medium. Other valves shall be capable of passing the pressure tests described in API 598, using helium as the test medium.

(b) Threaded valves shall be threaded according to ASME B1.20.1 or API 5B.

(c) Pressure reducing devices shall conform to the requirements of this Code for valves in comparable service conditions.

#### PL-2.2.3 Flanges

(a) *Flange Types and Facings*

(1) Line or end flanges shall conform to all the requirements of one of the following standards:

(-a) ASME B16 series standards listed in [Mandatory Appendix II](#)

(-b) MSS SP-44

Flanges cast or forged integral with fittings or valves are permitted in sizes and pressure classes covered by the standards listed above, subject to the facing, bolting, and gasketing requirements of this paragraph and the requirements for bolting and gaskets below.

(2) Threaded flanges that comply with ASME B16.5 are permitted.

(3) Lapped flanges are permitted in sizes and pressure classes established in ASME B16.5.

(4) Slip-on welding flanges are permitted in sizes and pressure classes established in ASME B16.5. Slip-on flanges of rectangular section may be substituted for hubbed slip-on flanges provided the thickness is increased as required to produce equivalent strength as determined by calculations made in accordance with ASME BPVC, Section VIII, Division 1, [Mandatory Appendix 2](#).

(5) Welding neck flanges are permitted in sizes and pressure classes established in ASME B16.5, MSS SP-44, and ASME B16.47 for large flanges. The bore of the flange should correspond to the inside diameter of the pipe used. For allowable weld end detail, see [para. GR-3.4.5](#).



(6) Cast iron and cast ductile iron flanges shall not be used in hydrogen service.

*(b) Bolting*

(1) For all flange joints, the bolts or stud bolts used shall extend either completely through the nuts or one thread short of the full nut.

(2) For all flange joints, the bolting shall be made of alloy steel conforming to ASTM A193, ASTM A320, or ASTM A354, or of heat-treated carbon steel conforming to ASTM A449. However, bolting may be made of Grade B of ASTM A307 for ASME B16.5 Class 150 and 300 flanges at temperatures between  $-30^{\circ}\text{C}$  ( $-20^{\circ}\text{F}$ ) and  $200^{\circ}\text{C}$  ( $400^{\circ}\text{F}$ ).

(3) Alloy-steel bolting material conforming to ASTM A193 or ASTM A354 shall be used for insulating flanges if such bolting is made 3 mm ( $\frac{1}{8}$  in.) undersized.

(4) The materials used for nuts shall conform to ASTM A194 or ASTM A307. ASTM A307 nuts may be used only with ASTM A307 bolting.

(5) All carbon and alloy-steel bolts, stud bolts, and their nuts shall be threaded in accordance with the following thread series and dimension classes required by ASME B1.1:

*(-a) Carbon Steel.* All carbon-steel bolts and stud bolts shall have coarse threads having Class 2A dimensions, and their nuts shall have Class 2B dimensions.

*(-b) Alloy Steel.* All alloy-steel bolts and stud bolts of 25 mm (1 in.) and smaller nominal diameter shall be of the coarse-thread series; nominal diameters 28 mm ( $1\frac{1}{8}$  in.) and larger shall be of the 8-thread series. Bolts and stud bolts shall have a Class 2A dimension; their nuts shall have a Class 2B dimension.

(6) Bolts shall have regular square heads or heavy hexagonal heads conforming to ASME B18.2.1 and shall have heavy hexagonal nuts conforming to the dimensions of ASME B18.2.2.

*(c) Gaskets*

(1) Material for gaskets shall be capable of withstanding the maximum pressure and of maintaining a seal under any credible conditions to which it might be subjected in service. Gaskets should be designed to avoid complete failure of seal during a fire.

(2) Gaskets used under pressure and at temperatures above  $121^{\circ}\text{C}$  ( $250^{\circ}\text{F}$ ) shall be of noncombustible material.

(3) Flat-ring gaskets with an outside diameter extending to the inside of the bolt holes may be used with raised-face steel flanges, or with lapped steel flanges.

(4) Rings for ring joints shall be of dimensions established in ASME B16.20. The material for these rings shall be suitable for the service conditions encountered and shall be softer than the flanges.

(5) The insulating material shall be suitable for the temperature, moisture, and other conditions where it will be used.

## PL-2.2.4 Fittings Other Than Valves and Flanges

*(a) Standard Fittings*

(1) Steel butt welding fittings shall comply with either ASME B16.9 or MSS SP-75 and shall have pressure and temperature ratings based on stresses for pipe of the same or equivalent material. For adequacy of fitting design, the actual bursting strength of fittings shall be at least equal to the computed bursting strength of pipe of the designated material and wall thickness.

(2) Steel socket-welding fittings shall comply with ASME B16.11.

*(b) Special Fittings.* When special, forged, wrought, or welded fittings are required to dimensions differing from those of regular shapes specified in the applicable referenced standards, the provisions of [para. PL-2.2.6](#) shall apply.

*(c) Branch Connections*

(1) Fabricated branch connections on steel pipe shall meet the design requirements of [paras. PL-2.3](#) and [PL-2.4](#).

(2) Mechanical fittings may be used for making hot taps on pipelines and mains, provided they are designed for the operating pressure and temperature of the pipeline or main.

(3) MSS SP-97 fittings are acceptable.

*(d) Special Components Fabricated by Welding*

(1) This section covers piping system components other than assemblies consisting of pipe and fittings joined by circumferential welds.

(2) All welding shall be performed using procedures and operators that are qualified in accordance with the requirements of [para. GR-3.2.4](#).

(3) Branch connections shall meet the design requirements of [paras. PL-2.3](#) and [PL-2.4](#).

(4) Prefabricated units, other than regularly manufactured butt-welding fittings, that employ plate and longitudinal seams, as contrasted with pipe that has been produced and tested under one of the specifications listed in this Part, shall be designed, constructed, and tested under requirements of ASME BPVC, Section VIII, Division 1. These requirements are not intended to apply to such partial assemblies as split rings or collars, or to other field-welded details.

(5) Prefabricated units produced under this section of the Code shall withstand a pressure test without failure, leakage, distress, or distortion other than elastic distortion at a pressure equal to the test pressure of the system in which they are installed, either before installation or during the system test. When such units are to be installed in existing systems, they shall be pressure tested before installation, unless the complete system is pressure tested after installation.

### PL-2.2.5 Pressure Design of Other Pressure-Containing Components

Pressure-containing components that are not covered by the standards listed in [Mandatory Appendix II](#) and for which design equations or procedures are not given herein may be used when the design of similarly shaped, proportioned, and sized components has been proven satisfactorily by successful service under comparable service conditions. (Interpolation may be made between similarly shaped components with small differences in size or proportion.) In the absence of such service experience, the pressure design shall be based on an analysis consistent with the design requirements in this Code and substantiated by at least one of the following:

- (a) proof tests, as prescribed in UG-101 of ASME BPVC, Section VIII, Division 1
- (b) experimental stress analysis, as prescribed in Section VIII, Division 2
- (c) finite element analysis

### PL-2.2.6 Closures

(a) *Quick Opening Closures.* A quick opening closure is a pressure-containing component (see [para. PL-2.2.5](#)) used for repeated access to the interior of a piping system. It is not the intent of this Code to impose the requirements of a specific design method on the designer or manufacturer of a quick opening closure. Quick opening closures shall have pressure and temperature ratings equal to or in excess of the design requirements of the piping system to which they are attached. Quick opening closures shall be equipped with safety locking devices in compliance with ASME BPVC, Section VIII, Division 1, UG-35(b). Weld end preparation shall be in accordance with [para. GR-3.4.3](#).

(b) *Closure Fittings.* Closure fittings commonly referred to as “weld caps” shall be designed and manufactured in accordance with ASME B16.9 or MSS SP-75. [See [para. PL-2.2.4\(a\)\(2\)](#).]

(c) *Closure Heads.* Closure heads such as flat, ellipsoidal [other than in [para. PL-2.2.4\(b\)](#)], spherical, or conical heads are permitted for use under this Part. Such items may be designed in accordance with ASME BPVC, Section VIII, Division 1. For closure heads not designed to Section VIII, Division 1, the maximum allowable stresses for materials used in these closure heads shall be established under the provisions of [para. PL-3.7](#) and shall not exceed a 50% SMYS. If welds are used in the fabrication of these heads, they shall be examined in accordance with the provisions of this Part. Closure heads shall have pressure and temperature ratings equal to or in excess of the design requirement of the piping system to which they are attached.

## PL-2.3 REINFORCEMENT OF FABRICATED BRANCH CONNECTIONS

### PL-2.3.1 Branch Connection Requirements

All fabricated branch connections shall meet the following requirements:

(a) When branch connections are made to pipe in the form of a single connection or in a header or manifold as a series of connections, the design must be adequate to control the stress levels in the pipe within safe limits. The construction shall accommodate the stresses in the remaining pipe wall due to the opening in the pipe or header, the shear stresses produced by the pressure acting on the area of the branch opening, and any external loadings due to thermal movement, weight, vibration, etc. The following paragraphs provide design rules for the usual combinations of the above loads, except for excessive external loads.

(b) The reinforcement required in the crotch section of a welded branch connection shall be determined by the rule that the metal area available for reinforcement shall be equal to or greater than the required area as defined in this paragraph as well as in [Nonmandatory Appendix F](#).

(c) The required cross-sectional area,  $AR$ , is defined as the product of  $d$  times  $t$

$$AR = dt$$

where

- $d$  = greater of the length of the finished opening in the header wall measured parallel to the axis of the run or the inside diameter of the branch connection
- $t$  = nominal header wall thickness required by [para. PL-3.7.1](#) for the design pressure and temperature. When the pipe wall thickness includes an allowance for corrosion or erosion, all dimensions used shall result after the anticipated corrosion or erosion has taken place.

(d) The area available for reinforcement shall be the sum of

(1) the cross-sectional area resulting from any excess thickness available in the header thickness over the minimum required for the header as defined in (c) above and that lies within the reinforcement area as defined in (e) below.

(2) the cross-sectional area resulting from any excess thickness available in the branch wall thickness over the minimum thickness required for the branch and that lies within the reinforcement area as defined in (e) below.

(3) the cross-sectional area of all added reinforcing metal that lies within the reinforcement area, as defined in (e) below, including that of solid weld metal that is conventionally attached to the header and/or branch.

(e) The area of reinforcement, shown in [Nonmandatory Appendix F](#), is defined as a rectangle whose length shall extend a distance,  $d$ , on each side of the transverse centerline of the finished opening and whose width shall extend a distance of  $2\frac{1}{2}$  times the header wall thickness on each side of the surface of the header wall. In no case, however, shall it extend more than  $2\frac{1}{2}$  times the thickness of the branch wall from the outside surface of the header or of the reinforcement, if any.

(f) The material of any added reinforcement shall have an allowable working stress at least equal to that of the header wall, except that material of lower allowable stress may be used if the area is increased in direct ratio of the allowable stress for header and reinforcement material, respectively.

(g) The material used for ring or saddle reinforcement may be of specifications differing from those of the pipe, provided the cross-sectional area is made in direct proportion to the relative strength of the pipe and reinforcement materials at the operating temperatures, and provided it has welding qualities comparable to those of the pipe. No credit shall be taken for the additional strength of material having a higher strength than that of the part to be reinforced.

(h) When rings or saddles cover the weld between branch and header, a vent hole shall be provided in the ring or saddle to reveal leakage in the weld between branch and header, and to provide venting during welding and heat-treating operations. Vent holes should be plugged during service to prevent crevice corrosion between pipe and reinforcing member, but no plugging material that would be capable of sustaining pressure within the crevice should be used.

(i) The use of ribs or gussets shall not be considered as contributing to reinforcement of the branch connection. This does not prohibit the use of ribs or gussets for purposes other than reinforcement, such as stiffening.

(j) The branch shall be attached by a weld for the full thickness of the branch or header wall plus a fillet weld, as required by [para. GR-3.4.9](#). The use of concave fillet welds is preferred to further minimize corner stress concentration. Ring or saddle reinforcement shall be attached as required by [para. GR-3.4.9](#). When a full fillet is not used, it is recommended that the edge of the reinforcement be relieved or chamfered at approximately 45 deg to merge with the edge of the fillet. (See [Nonmandatory Appendix F](#).)

(k) Reinforcement rings and saddles shall be accurately fitted to the parts to which they are attached. [Paragraph GR-3.4.9](#) describes some acceptable forms of reinforcement.

(l) Branch connections attached at an angle less than 85 deg to the run become progressively weaker as the angle decreases. Any such design must be given individual study, and sufficient reinforcement must be provided to compen-

sate for the inherent weakness of such construction. The use of encircling ribs to support the flat or reentering surfaces is permissible and may be included in the strength calculations. The designer is cautioned that stress concentrations near the ends of partial ribs, straps, or gussets may defeat their reinforcing value.

### PL-2.3.2 Special Requirements

In addition to the requirements of [para. PL-2.3.1](#), branch connections must meet the requirements described in [Table PL-2.3.2-1](#).

(a) Smoothly contoured wrought steel tees of proven design are preferred. When tees cannot be used, the reinforcing member shall extend around the circumference of the header. Pads, partial saddles, or other types of localized reinforcement are prohibited.

(b) Smoothly contoured tees of proven design are preferred. When tees are not used, the reinforcing member should be of the complete encirclement type, but may be of the pad type, saddle type, or a welding outlet fitting type.

(c) The reinforcement member may be of the complete encirclement type, pad type, saddle type, or welding outlet fitting type. The edges of reinforcement members should be tapered to the header thickness. It is recommended that legs of fillet welds joining the reinforcing member and header do not exceed the thickness of the header.

(d) Reinforcement calculations are not required for openings 50 mm (2 in.) and smaller in diameter, or integrally reinforced forged branch outlet fittings conforming to MSS SP-97. Care should be taken to provide suitable protection against vibrations and other external forces to which these small openings are frequently subjected.

(e) All welds joining the header, branch, and reinforcing member shall meet the requirements of [para. GR-3.4.9](#). See [Nonmandatory Appendix F](#).

(f) The inside edges of the finished opening shall, whenever possible, be rounded to a 3 mm ( $\frac{1}{8}$  in.) radius. If the encircling member is thicker than the header and is welded to the header, the ends shall be tapered down to the header thickness and continuous fillet welds shall be made.

(g) Reinforcement of openings is not mandatory; however, reinforcement may be required for special cases involving pressures over 690 kPa (100 psi), thin wall pipe, or severe external loads.

(h) If a reinforcement member is required and the branch diameter is such that a localized type of reinforcement member would extend around more than half the circumference of the header, then a complete encirclement type of reinforcement member shall be used, regardless of the design hoop stress, or a smoothly contoured wrought steel tee of proven design may be used.

(i) The reinforcement may be of any type meeting the requirements of [para. PL-2.3.1](#).

**Table PL-2.3.2-1**  
**Reinforcement of Fabricated Branch Connections, Special Requirements**

| Ratio of Design Hoop Stress to Minimum Specified Yield Strength in the Header | Ratio of Nominal Branch Diameter to Nominal Header Diameter |                           |               |
|---|---|---------------------------|---------------|
|   | 25% or Less   | More Than 25% Through 50% | More Than 50% |
| 20% or less   | (g)   | (g)                       | (h)           |
| More than 20% through 50%   | (d), (i)  | (i)                       | (h), (i)      |
| More than 50%   | (c), (d), (e)   | (b), (e)                  | (a), (e), (f) |

GENERAL NOTE: The letters in the table correspond to the subparagraphs of [para. PL-2.3.2](#).

## PL-2.4 MULTIPLE OPENINGS AND EXTRUDED OUTLETS

### PL-2.4.1 Reinforcement of Multiple Openings

(a) When two or more adjacent branches are spaced at less than 2 times their average diameter (so that their effective areas of reinforcement overlap), the group of openings shall be reinforced in accordance with [para. PL-2.3](#). The reinforcing metal shall be added as a combined reinforcement, the strength of which shall equal the combined strengths of the reinforcements that would be required for the separate openings. In no case shall any portion of a cross section be considered to apply to more than one opening or be evaluated more than once in a combined area.

(b) When more than two adjacent openings are to be provided with a combined reinforcement, the minimum distance between centers of any two of these openings shall preferably be at least  $1\frac{1}{2}$  times their average diameter, and the area of reinforcement between them shall be at least equal to 50% of the total required for these two openings on the cross section being considered.

(c) When the distance between centers of two adjacent openings is less than  $1\frac{1}{3}$  times their average diameter, as considered under (b) above, no credit for reinforcement shall be given for any of the metal between these two openings.

(d) Any number of closely spaced adjacent openings in any arrangement may be reinforced as if the group were treated as one assumed opening of a diameter enclosing all such openings.

### PL-2.4.2 Extruded Outlets

(a) The rules in this paragraph apply to steel extruded outlets in which the reinforcement is integral. An extruded outlet is an outlet in which the extruded lip at the outlet has a height above the surface of the run that is equal to or greater than the radius of curvature of the external contoured portion of the outlet, as required by [para. GR-3.4.9](#) and [Figure GR-3.4.9-4](#). See [Nonmandatory Appendix F](#).

(b) These rules do not apply to any nozzles or branch connections in which additional nonintegral material is applied in the form of rings, pads, or saddles.

(c) These rules apply only to cases where the axis of the outlet intersects and is perpendicular to the axis of the run.

(d) See [Nonmandatory Appendix F](#) for the pertinent dimensions and limiting conditions.

(e) The required area is defined as

$$A = Kt_r D_o$$

where

$$\begin{aligned} K &= 1.0 \text{ for } d/D > 0.60 \\ &= 0.6 + \frac{2}{3}(d/D) \text{ for } 0.60 > d/D > 0.15 \\ &= 0.70 \text{ for } d/D < 0.15 \end{aligned}$$

The design must meet the criterion that the reinforcement area defined in (f) below is not less than the required area.

(f) The reinforcement area shall be the sum of areas  $A_1 + A_2 + A_3$  as defined below.

(1) Area  $A_1$  is the area lying within the reinforcement zone resulting from any excess thickness available in the run wall, i.e.,  $A_1 = D_o(T_r - t_r)$ .

(2) Area  $A_2$  is the area lying within the reinforcement zone resulting from any excess thickness available in the branch pipe wall, i.e.,  $A_2 = 2L(T_b - t_b)$ .

(3) Area  $A_3$  is the area lying within the reinforcement zone resulting from excess thickness available in the extruded outlet lip, i.e.,  $A_3 = 2r_o(T_o - t_b)$ .

(g) For reinforcement of multiple openings, the rules in [para. PL-2.4.1](#) shall be followed, except that the required area and the reinforcement area shall be as given in [para. PL-2.4.2](#).

(h) The manufacturer shall be responsible for establishing and marking, on the section containing extruded outlets, the following: the design pressure, temperature, and that these values were established under provisions of this Code. The manufacturer's name or trademark shall be marked on the section.



(23) **Table PL-2.5.2-1**  
**Thermal Expansion of Carbon and Low Alloy Steel**

| Temperature,<br>°C | Total<br>Expansion,<br>mm/m, in Going<br>From 20°C to<br>Indicated<br>Temperature | Temperature,<br>°F | Total Expansion,<br>in./100 ft, in<br>Going From 70°F<br>to Indicated<br>Temperature |
|--------------------|---|--------------------|--|
| -50                | -0.8  | -50                | -0.9   |
| 20                 | 0   | 70                 | 0  |
| 75                 | 0.7   | 150                | 0.6  |
| 100                | 1.0   | 200                | 1.0  |
| 125                | 1.3   | 250                | 1.5  |
| 150                | 1.6   | 300                | 1.9  |
| 175                | 2.0   | 350                | 2.4  |
| 200                | 2.3   | 400                | 2.8  |
| 225                | 2.6   | 450                | 3.3  |
| 250                | 3.0   | 500                | 3.7  |

## PL-2.5 EXPANSION AND FLEXIBILITY

### PL-2.5.1 Application

Paragraph PL-2.5 is applicable to piping meeting the definition of unrestrained piping in para. PL-2.6.1(c).

### PL-2.5.2 Amount of Expansion

The thermal expansion of the more common grades of steel used for piping may be determined from Table PL-2.5.2-1. For materials not included in Table PL-2.5.2-1 or for more precise calculations, reference may be made to authoritative source data.

### (23) PL-2.5.3 Flexibility Requirements

(a) Pipeline systems shall be designed to have sufficient flexibility to prevent thermal expansion or contraction from causing excessive stresses in the piping material, excessive bending or unusual loads at joints, or undesirable forces or moments at points of connection to equipment or at anchorage or guide points. Formal calculations shall be performed where reasonable doubt exists as to the adequate flexibility of the system. See para. PL-2.6.6 for further guidance.

(b) Flexibility shall be provided by the use of bends, loops, or offsets, or provision shall be made to absorb thermal changes by the use of expansion joints of the bellows type. If expansion joints are used, anchors or ties of sufficient strength and rigidity shall be installed to provide for end forces due to fluid pressure and other causes.

(c) In calculating the flexibility of a piping system, the system shall be treated as a whole. The significance of all parts of the line and all restraints, such as rigid supports or guides, shall be considered.

(d) Calculations shall take into account stress intensification factors found to exist in components other than plain straight pipe. Credit may be taken for the extra flexibility of such components. The flexibility factors and stress intensification factors shown in ASME B31.8, Appendix E, Table E-1 may be used.

(e) Properties of pipe and fittings for these calculations shall be based on nominal dimensions, and the joint factor  $E$  shall be taken as 1.00.

(f) The total range in temperature shall be considered in all expansion calculations, whether piping is cold sprung or not. In addition to the expansion of the line itself, the linear and angular movements of the equipment to which it is attached shall be considered.

(g) Flexibility calculations shall be based on the modulus of elasticity corresponding to the lowest temperature of the operational cycle.

(h) In order to modify the effect of expansion and contraction, runs of pipe may be cold sprung. Cold spring may be taken into account in the calculations of the reactions, provided an effective method of obtaining the designed cold spring is specified and used. See additional discussion of cold spring in ASME B31.3, para. 319.2.4.

### PL-2.5.4 Reactions

(a) Reaction forces and moments to be used in the design of restraints and supports for a piping system, and in evaluating the effects of piping displacements on connected equipment, shall consider the full range of thermal displacement conditions plus weight and external loads. Cold spring may be useful for maintaining reactions within acceptable limits.

(b) The reactions for thermal displacements shall be calculated using the elastic modulus corresponding to the lowest temperature of an operational cycle.

(c) Consideration shall be given to the load-carrying capacity of attached rotating and pressure-containing equipment and the supporting structure.

### PL-2.5.5 Modulus of Elasticity

The modulus of elasticity for carbon and low alloy steel at various temperatures is given in Table PL-2.5.5-1. Values between listed temperatures may be linearly interpolated.

## PL-2.6 DESIGN FOR LONGITUDINAL STRESS

### PL-2.6.1 Restraint

(a) The restraint condition is a factor in the structural behavior of the pipeline. The degree of restraint may be affected by aspects of pipeline construction, support design, soil properties, and terrain. This paragraph is applicable to steel piping. For purposes of design, this Code recognizes two axial restraint conditions, "restrained" and

Table PL-2.5.5-1

(23) **Modulus of Elasticity for Carbon and Low Alloy Steel**

| Temperature, °C | Modulus of Elasticity, MPa × 10 <sup>3</sup> | Temperature, °F | Modulus of Elasticity, psi × 10 <sup>6</sup> |
|-----------------|--|-----------------|--|
| -75             | 209  | -100            | 30.1   |
| 25              | 207  | 70              | 29.4   |
| 100             | 198  | 200             | 28.8   |
| 150             | 195  | 300             | 28.3   |
| 200             | 192  | 400             | 27.4   |
| 250             | 189  | 500             | 27.3   |

“unrestrained.” Guidance in categorizing the restraint condition is given below.

(b) Piping in which soil or supports prevent axial displacement of flexure at bends is restrained. Restrained piping may include the following:

(1) straight sections of buried piping

(2) bends and adjacent piping buried in stiff or consolidated soil

(3) sections of above-ground piping on rigid supports

(c) Piping that is freed to displace axially or flex at bends is unrestrained. Unrestrained piping may include the following:

(1) above-ground piping that is configured to accommodate thermal expansion or anchor movements through flexibility

(2) bends and adjacent piping buried in soft or unconsolidated soil

(3) an unbackfilled section of otherwise buried pipeline that is sufficiently flexible to displace laterally or which contains a bend

(4) pipe subject to an end cap pressure force

(23) **PL-2.6.2 Calculation of Longitudinal Stress Components**

(a) The longitudinal stress due to internal pressure in restrained pipelines is

$$S_p = 0.3S_H$$

where

$S_H$  = hoop stress

(b) The longitudinal stress due to internal pressure in unrestrained pipeline is

$$S_p = 0.5S_H$$

where

$S_H$  = hoop stress

(c) The longitudinal stress due to thermal expansion in restrained pipe is

$$S_T = E\alpha(T_1 - T_2)$$

where

$E$  = elastic modulus at the ambient temperature

$T_1$  = pipe temperature at the time of installation, tie-in, or burial

$T_2$  = warmest or coldest pipe operating temperature

$\alpha$  = coefficient of thermal expansion

If a section of pipe can operate either warmer or colder than the installed temperature, both conditions for  $T_2$  may need to be examined.

(d) The nominal bending stress in straight pipe or large-radius bends due to weight or other external loads is

$$S_B = M/Z$$

where

$M$  = bending moment across the pipe cross section

$Z$  = pipe section modulus

(e) The nominal bending stress in fittings and components due to weight or other external loads is

$$S_B = M_R/Z$$

where  $M_R$  is the resultant intensified moment across the fitting or component. The resultant moment shall be calculated as

$$M_R = \left[ (0.75i_i M_i)^2 + (0.75i_o M_o)^2 + M_t^2 \right]^{1/2}$$

where

$i_i$  = in-plane stress intensification factor from ASME B31.8, Mandatory Appendix E, Table E-1

$i_o$  = out-of-plane stress intensification factor from ASME B31.8, Mandatory Appendix E, Table E-1

$M_i$  = in-plane bending moment

$M_o$  = out-of-plane bending moment

$M_t$  = torsional moment

The product  $0.75i_i \geq 1.0$ .

(f) The stress due to axial loading other than thermal expansion and pressure is

$$S_X = R/A$$

where

$A$  = pipe metal cross-sectional area

$R$  = external force axial component

**PL-2.6.3 Summation of Longitudinal Stress in Restrained Pipe**

(a) The net longitudinal stresses in restrained pipe are

$$S_L = S_p + S_T + S_X + S_B$$

Note that  $S_L$ ,  $S_T$ ,  $S_X$ , or  $S_B$  can have negative values.

(b) The maximum permitted value of  $S_L$  shall not exceed  $0.9ST$ , where  $S$  is the SMYS per [para. PL-3.7.1\(a\)](#) and  $T$  is the temperature derating factor per [Table PL-3.7.1-3](#).

(c) Residual stresses from construction are often present, for example, bending in buried pipelines where spanning or differential settlement occurs. These stresses are often difficult to evaluate accurately, and can be disregarded in most cases. It is the engineer's responsibility to determine if such stresses should be evaluated.

#### PL-2.6.4 Combined Stress for Restrained Pipe

(a) The combined biaxial stress state of the pipeline in the operating mode is evaluated using the calculation in either (1) or (2) below

$$(1) |S_H - S_L|$$

$$(2) \left( S_L^2 - S_L S_H + S_H^2 \right)^{1/2}$$

The maximum permitted value for the combined biaxial stress is  $kST$ , where  $S$  is the SMYS per [para. PL-3.7.1\(a\)](#),  $T$  is the temperature derating factor per [Table PL-3.7.1-3](#), and  $k$  is defined in (b) and (c) below.

(b) For loads of long duration, the value of  $k$  shall not exceed 0.90.

(c) For occasional nonperiodic loads of short duration, the value of  $k$  shall not exceed 1.0.

(d)  $S_L$  in [para. PL-2.6.3](#) is calculated considering both the tensile and compressive values of  $S_B$ .

(e) Stresses induced by loads that do not occur simultaneously need not be considered to be additive.

(f) The biaxial stress evaluation described above applies only to straight sections of pipe.

#### (23) PL-2.6.5 Summation of Longitudinal Stresses in Unrestrained Pipe

(a) The net longitudinal stress in unrestrained pipe is

$$S_L = S_P + S_X + S_B$$

(b) The maximum permitted longitudinal stress in unrestrained pipe is

$$S_L \leq 0.75ST$$

where

$S$  = SMYS per [para. PL-3.7.1\(a\)](#)

$T$  = temperature derating factor per [Table PL-3.7.1-3](#)

#### (23) PL-2.6.6 Flexibility Analysis for Unrestrained Piping

(a) There is no need for formal flexibility analysis for an unrestrained piping system that

(1) duplicates or replaces, without significant change, a system operating with a successful record

(2) can be readily judged adequate by comparison with previously analyzed systems

(3) is of uniform size, has no more than two points of fixation, no intermediate restraints, and falls within the limitations of the following empirical equation:

$$K \geq DY / (L - U)^2$$

where

$D$  = nominal outside diameter of pipe, mm (in.)

$K$  = 208 for SI units

= 0.03 for U.S. Customary units

$L$  = developed length of piping between anchors, m (ft)

$U$  = straight line separation between anchors, m (ft)

$Y$  = resultant of total displacement strains, mm (in.), to be absorbed by the system

NOTE: No general proof can be offered that this empirical equation always yields conservative results. It is not applicable to systems used in severe cyclic conditions. It should be used with caution in configurations such as unequal leg U-bends having  $L/U > 2.5$ ; nearly straight "sawtooth" runs, where  $i \geq 5$  due to thin-walled design; or where displacements not in the direction connecting anchor points constitute a large part of the total displacement. There is no assurance that terminal reactions will be acceptably low even if a piping system falls within the limitations of (a)(3) above.

(b) Any piping system that does not meet one of the criteria in (a) above should undergo a flexibility stress analysis by a simplified, approximate, or comprehensive method, as deemed appropriate.

#### PL-2.6.7 Flexibility Stresses and Stresses Due to Periodic or Cyclic Loading

Calculations and good practices for pipeline components subject to stresses due to periodic or cyclic loading should conform to [para. IP-2.2.10](#).

#### PL-2.6.8 Local Stresses

(a) High local stresses are usually generated at structural discontinuities and sites of local loadings. Although they may exceed the material yield strength, such stresses may often be disregarded because they are localized in influence and may be self-limiting or relieved by local deformation. Examples include stresses in branch connections caused by pressure or external loads, or stresses at structural discontinuities. This Code does not fully address the maximum allowable value for local stresses. It is the engineer's responsibility to determine whether such stresses must be evaluated.

(b) The maximum allowable sum of circumferential stress due to internal pressure and circumferential through-wall bending stress caused by surface vehicle loads or other local loads is  $0.9ST$ , where  $S$  is the



SMYS per [para. PL-3.7.1\(a\)](#) and  $T$  is the temperature derating factor per [Table PL-3.7.1-3](#).

(c) Local stresses in (a) or (b) above caused by periodic or repetitive loads may require further limitations in consideration of fatigue.

## **PL-2.7 SUPPORTS AND ANCHORAGE FOR EXPOSED PIPING**

### **PL-2.7.1 Piping and Equipment**

Piping and equipment shall be supported in a substantial and workmanlike manner, so as to prevent or reduce excessive vibration, and shall be anchored sufficiently to prevent undue strains on connected equipment.

### **PL-2.7.2 Provision for Expansion**

Supports, hangers, and anchors should be so installed as not to interfere with the free expansion and contraction of the piping between anchors.

### **PL-2.7.3 Materials, Design, and Installation**

All permanent hangers, supports, and anchors shall be fabricated from durable incombustible materials, and designed and installed in accordance with good engineering practice for the service conditions involved. All parts of the supporting equipment shall be designed and installed so that they will not be disengaged by movement of the supported piping.

### **PL-2.7.4 Forces on Pipe Joints**

(a) All exposed pipe joints shall be able to sustain the maximum end force due to the internal pressure, i.e., the design pressure times the internal area of the pipe as well as any additional forces due to temperature expansion or contraction or to the weight of pipe and contents.

(b) If compression or sleeve-type couplings are used in exposed piping, provision shall be made to sustain the longitudinal forces noted in (a) above. If such provision is not made in the manufacture of the coupling, suitable bracing or strapping shall be provided, but such design must not interfere with the normal performance of the coupling nor with its proper maintenance. Attachments must meet the requirements of [para. PL-2.7.5](#).

### **PL-2.7.5 Attachment of Supports or Anchors**

(a) If the pipe is designed to operate at a hoop stress of less than 20% of the SMYS, structural supports or anchors may be welded directly to the pipe.

(b) If the pipe is designed to operate at a hoop stress of 20% or more of the SMYS, support of the pipe shall be furnished by a member that completely encircles it. Where it is necessary to provide positive attachment, as at an anchor, the pipe may be welded to the encircling member; the support shall be attached to the encircling

member and not to the pipe. The connection of the pipe to the encircling member shall be by continuous welds, rather than intermittent welds. If there are continuous welds, a vent hole shall be provided at the side of the encircling member. Vent holes may be plugged during service to prevent, e.g., entry of injurious fluids, but the plugging material shall not be capable of sustaining pressure.

## **PL-2.8 ANCHORAGE FOR BURIED PIPING**

### **PL-2.8.1 Pipe Bends or Offsets**

Bends or offsets in buried pipe cause longitudinal forces that must be resisted by anchorage at the bend, by restraint due to friction of the soil, or by longitudinal stresses in the pipe.

### **PL-2.8.2 Anchorage at Bends**

If the pipe is anchored by bearing at the bend, care shall be taken to distribute the load on the soil so that the bearing pressure is within the capability of the soil involved.

### **PL-2.8.3 Restraint Due to Soil Friction**

Where there is doubt as to the adequacy of restraint friction, calculations shall be made and indicated anchoring shall be installed.

### **PL-2.8.4 Forces on Pipe Joints**

If anchorage is not provided at the bend (see [para. PL-2.8.2](#)), pipe joints that are close to the points of thrust origin shall be designed to sustain the longitudinal pullout force. If such provision is not made in the manufacture of the joints, bracing or strapping that absorbs the pressure thrust shall be provided.

### **PL-2.8.5 Supports for Buried Piping**

In pipelines, especially those that are highly stressed from internal pressure, uniform and adequate support of the pipe in the trench is essential. Unequal settlements may produce added bending stresses in the pipe. Lateral thrusts at branch connections may greatly increase the stresses in the branch connection itself, unless the fill is thoroughly consolidated or other provisions are made to resist the thrust. Rock shield shall not be draped over the pipe unless suitable backfill and padding are placed in the ditch to provide a continuous and adequate support of the pipe in the trench.

When openings are made in a consolidated backfill to connect new branches to an existing line, care shall be taken to provide firm foundation for both the header and the branch in order to prevent differential movements.

**PL-2.8.6 Interconnection of Underground Lines**

Underground lines are subjected to longitudinal stresses due to changes in pressure and temperature. For long lines, the friction of the earth will prevent changes in length from these stresses, except for several hundred feet adjacent to bends or ends. At these locations, the movement, if unrestrained, may be

of considerable magnitude. If a connection to a relatively unyielding line or other fixed object is made at such a location, the line shall have ample flexibility to compensate for differential movement, or the line shall be provided with an anchor sufficient to develop the forces necessary to limit the movement.

## Chapter PL-3

# Design, Installation, and Testing

### PL-3.1 PROVISIONS FOR DESIGN

#### PL-3.1.1 Conditions

The design requirements of this Code are intended to address conditions encountered in the hydrogen gas transmission industry. Conditions that may cause additional stress in any part of a line or its appurtenances shall be further addressed following recognized good engineering practice. Examples of such conditions include long self-supported spans, unstable ground, mechanical or acoustic vibration, weight of special attachments, earthquake-induced displacements, temperature and pressure differential, and the soil and conditions found in the Arctic or another harsh environment. Temperature and pressure differences shall be taken as the difference between the lowest and highest values expected during pressure test and operation, considering recorded data and the possible effects of lower or higher air and ground temperatures.

#### PL-3.1.2 Quality

The quality of the hydrogen gas to be transported in the pipeline, or by the pipeline system, shall be considered when designing facilities. Steps shall be taken to control or minimize adverse effects of the hydrogen gas components when either of the following may be a concern:

(a) *Composition.* For certain applications, such as for fuel cells, pure hydrogen is transported. A pipeline may transport blends of hydrogen and other fuel gases such as methane, propane, etc. Potential concern may include hydrogen leak detection along cross-country pipelines. This may require advanced investigative assessments.

(b) *Additives.* When an odorant or chemical is used, the effect of chemical composition of these additives should be investigated for ensuring negligible impact on material degradation.

#### PL-3.1.3 Damage

The most significant factor contributing to the failure of a hydrogen gas pipeline is damage to the line caused by third-party activities. Damage can occur during construction of other facilities in the right-of-way associated with providing services for dwellings and other commercial or

industrial enterprises. These services include water, gas and electrical supply, sewage systems, drainage lines and ditches, buried power and communication cables, and streets and roads. They become more prevalent, and the possibility of damage to the pipeline becomes greater, with larger concentrations of buildings intended for human occupancy. Determining the Location Class provides a method of assessing the degree of exposure of the line to damage.

(a) A survey of building density shall be carried out (see paras. PL-3.2, PL-3.3, and PL-3.4) to determine the operational and design requirements necessary to protect the integrity of the pipeline in the presence of activities that might cause damage.

(b) If buildings intended for human occupancy are found to be within the potential impact area of a proposed hydrogen pipeline, a full risk assessment shall be carried out (see para. PL-3.5).

### PL-3.2 BUILDINGS INTENDED FOR HUMAN OCCUPANCY

#### PL-3.2.1 Determination of Number of Buildings Intended for Human Occupancy (23)

(a) To determine the number of buildings intended for human occupancy for a pipeline, lay out a zone 0.4 km ( $\frac{1}{4}$  mile) wide along the route of the pipeline with the pipeline on the centerline of this zone, and divide the pipeline into random sections 1.6 km (1 mile) in length such that the individual lengths will include the maximum number of buildings intended for human occupancy. Count the number of buildings intended for human occupancy within each 1.6-km (1-mile) zone. For this purpose, each separate dwelling unit in a multiple dwelling unit building is to be counted as a separate building intended for human occupancy. It is not intended here that a full 1.6 km (1 mile) of lower stress level pipeline shall be installed if there are physical barriers or other factors that will limit the further expansion of the more densely populated area to a total distance of less than 1.6 km (1 mile). It is intended, however, that where no such barriers exist, significant allowance shall be made in determining the limits of the lower stress design to provide for probable further development in the area.

(b) When a cluster of buildings intended for human occupancy indicates that a basic 1.6 km (1 mile) of pipeline should be identified as a Location Class 2 or Location Class 3, the Location Class 2 or Location Class 3 shall be terminated no closer than 200 m (660 ft) from the nearest building in the cluster.

(c) For pipelines shorter than 1.6 km (1 mile) in length, a Location Class that is typical of the Location Class that would be required for 1.6 km (1 mile) of pipeline with the same building population density shall be assigned.

(23) **PL-3.2.2 Location Classes for Design and Construction**

(a) *Location Class 1.* A Location Class 1 is any 1.6-km (1-mile) section that has ten or fewer buildings intended for human occupancy. A Location Class 1 is intended to reflect areas such as wasteland, deserts, wetlands, mountains, grazing land, farmland, and sparsely populated areas.

(1) *Class 1, Division 1.* As recognized in ASME B31.8, this Division is not applicable to hydrogen service and is not recognized in this Code.

(2) *Class 1, Division 2.* This Division is a Location Class 1 where the design factor of the pipe is equal to or less than 0.72 and has been tested to 1.1 times the maximum operating pressure. [See [Table PL-3.7.1-6](#) for exceptions to design factor.]

(b) *Location Class 2.* A Location Class 2 is any 1.6-km (1-mile) section that has more than 10 but fewer than 46 buildings intended for human occupancy. A Location Class 2 is intended to reflect areas where the degree of population is intermediate between Location Class 1 and Location Class 3, such as fringe areas around cities and towns, industrial areas, ranch or country estates, etc.

(c) *Location Class 3.* A Location Class 3 is any 1.6-km (1-mile) section that has 46 or more buildings intended for human occupancy, except when a Location Class 4 prevails. A Location Class 3 is intended to reflect areas such as suburban housing developments, shopping centers, residential areas, industrial areas, and other populated areas not meeting Location Class 4 requirements.

(d) *Location Class 4.* Location Class 4 includes areas where multistory buildings are prevalent, where traffic is heavy or dense, and where there may be numerous other utilities underground. Multistory means four or more floors above ground, including the first or ground floor. The depth of basements or number of basement floors is immaterial.

**PL-3.3 CONSIDERATIONS NECESSARY FOR CONCENTRATIONS OF PEOPLE IN LOCATION CLASS 1 OR CLASS 2**

**PL-3.3.1 Consequences of Failure**

In addition to the criteria contained in [para. PL-3.2](#), additional consideration shall be given to the possible consequences of a failure near areas where a concentration of people is likely, such as a house of worship, school, multiple dwelling unit, hospital, or recreational area of an organized character in Location Class 1 or Class 2. If the facility is used infrequently, the requirements of [para. PL-3.3.2](#) need not be applied. However, the depth of cover shall be adequate to assure integrity at all times during the life of the facilities.

**PL-3.3.2 Dense Concentration**

Pipelines near places of public assembly or concentrations of people, such as houses of worship, schools, multiple dwelling unit buildings, hospitals, or recreational areas of an organized nature in Location Class 1, Class 2, or Class 3, shall meet requirements for Location Class 4.

**PL-3.3.3 Low Concentration**

Concentrations of people referred to in [paras. PL-3.3.1](#) and [PL-3.3.2](#) above are not intended to include groups of fewer than 20 people per instance or location, but are intended to cover people in an outside area as well as in a building.

**PL-3.4 INTENT**

**PL-3.4.1 Definition**

Location Class (1, 2, 3, or 4) as described in the previous paragraphs is defined as the general description of a geographic area having certain characteristics as a basis for prescribing the types of design, construction, and methods of testing to be used in those locations, or in areas that are comparable. A numbered Location Class does not necessarily indicate that a particular design factor suffices for all construction in that particular location or area.

**PL-3.4.2 Future Development**

When classifying locations, consideration shall be given to the possibility of future development of the area. If such future development appears likely to be sufficient to change the Class Location, this shall be taken into consideration in the design and testing of the proposed pipeline.

**Table PL-3.6.1-1  
Location Class**

| Original [Note (1)]                    |                     | Current        |                     |   |
|--|---------------------|----------------|---------------------|---|
| Location Class                         | Number of Buildings | Location Class | Number of Buildings | Maximum Allowable Operating Pressure (MAOP)             |
| <b>Designed to Option A [Note (2)]</b> |                     |                |                     |   |
| 1 Division 2                           | 0-10                | 1              | 11-25               | Previous MAOP but not greater than 50% $S_m$ [Note (3)] |
| 1                                      | 0-10                | 2              | 26-45               | 0.800 × test pressure but not greater than 50% $S_m$    |
| 1                                      | 0-10                | 2              | 46-65               | 0.667 × test pressure but not greater than 50% $S_m$    |
| 1                                      | 0-10                | 3              | 66+                 | 0.667 × test pressure but not greater than 50% $S_m$    |
| 1                                      | 0-10                | 4              | [Note (4)]          | 0.555 × test pressure but not greater than 40% $S_m$    |
| 2                                      | 11-45               | 2              | 46-65               | Previous MAOP but not greater than 50% $S_m$            |
| 2                                      | 11-45               | 3              | 66+                 | 0.667 × test pressure but not greater than 50% $S_m$    |
| 2                                      | 11-45               | 4              | [Note (4)]          | 0.555 × test pressure but not greater than 40% $S_m$    |
| 3                                      | 46+                 | 4              | [Note (4)]          | 0.555 × test pressure but not greater than 40% $S_m$    |
| <b>Designed to Option B [Note (5)]</b> |                     |                |                     |   |
| 1 Division 2                           | 0-10                | 1              | 11-25               | Previous MAOP but not greater than 72% $S_m$ [Note (3)] |
| 1                                      | 0-10                | 2              | 26-45               | 0.800 × test pressure but not greater than 72% $S_m$    |
| 1                                      | 0-10                | 2              | 46-65               | 0.667 × test pressure but not greater than 60% $S_m$    |
| 1                                      | 0-10                | 3              | 66+                 | 0.667 × test pressure but not greater than 60% $S_m$    |
| 1                                      | 0-10                | 4              | [Note (4)]          | 0.555 × test pressure but not greater than 50% $S_m$    |
| 2                                      | 11-45               | 2              | 46-65               | Previous MAOP but not greater than 60% $S_m$            |
| 2                                      | 11-45               | 3              | 66+                 | 0.667 × test pressure but not greater than 60% $S_m$    |
| 2                                      | 11-45               | 4              | [Note (4)]          | 0.555 × test pressure but not greater than 40% $S_m$    |
| 3                                      | 46+                 | 4              | [Note (4)]          | 0.555 × test pressure but not greater than 40% $S_m$    |

## NOTES:

- (1) At time of design and construction.
- (2) For use with design option A, prescriptive design method [see para. PL-3.7.1(b)(1)]. Existing hydrogen pipelines not designed to this Code shall use this portion of the table for Location Class and MAOP changes.
- (3)  $S_m$  is the maximum allowable operating stress, calculated as specified minimum yield strength ×  $H_f$ , where  $H_f$  is the material performance factor from **Mandatory Appendix IX, Table IX-5A or IX-5B**. Material performance factors account for the adverse effects of hydrogen gas on the mechanical properties of carbon steels used in the construction of pipelines.
- (4) Multistory buildings become prevalent.
- (5) For use with design option B, performance-based method, para. PL-3.7.1(b)(2).

**PL-3.5 RISK ASSESSMENT**

(a) The potential impact radius of a proposed hydrogen pipeline shall be determined according to para. 3.2 of ASME B31.8S, modified by the substitution of the following in formula (1):

$$r = 0.47\sqrt{pd^2}$$

(b) If one or more buildings intended for human occupancy are found to be within the potential impact area of a proposed hydrogen pipeline, a full risk assessment shall be carried out. A method of risk assessment suitable for hydrogen pipelines is contained in section 4.6 of CGA G-5.6.

**PL-3.6 LOCATION CLASS AND CHANGES IN NUMBER OF BUILDINGS INTENDED FOR HUMAN OCCUPANCY****PL-3.6.1 Continuing Surveillance**

Upon initiating hydrogen service in a pipeline designed and constructed or converted to hydrogen service, the operating company shall determine the Location Class in accordance with **Table PL-3.6.1-1**.

(a) Existing pipelines or mains operating at hoop stress levels in excess of 20% of specified minimum yield strength shall be monitored at intervals not exceeding 3 yr to determine if additional buildings intended for human occupancy have been constructed. The total number of buildings intended for human occupancy

shall be counted to determine the current Location Class in accordance with the procedures specified in [paras. PL-3.2.2\(a\)](#) and [PL-3.2.2\(b\)](#).

(b) In accordance with the principles stated in [para. PL-3.1](#), the operating company shall determine the changes that should be made, such as limiting operating stress levels, frequency of patrolling, and cathodic protection requirements, as additional buildings intended for human occupancy are constructed.

(c) When there is an increase in the number of buildings intended for human occupancy to or near the upper limit of the Location Class listed in [Table PL-3.6.1-1](#), a study shall be completed within 6 months of perception of the increase. The study shall include

(1) the design, construction, and testing procedures followed in the original construction and a comparison of such procedures with the applicable provisions of this Code.

(2) the physical conditions of the pipeline or main to the extent that this can be ascertained from current tests and evaluation records.

(3) operating and maintenance history of the pipeline or main.

(4) the maximum operating pressure and the corresponding operating hoop stress. The pressure gradient may be taken into account in the section of the pipeline or main directly affected by the increasing number of buildings intended for human occupancy.

(5) the actual area affected by the increase in the number of buildings intended for human occupancy and physical barriers or other factors that may limit the further expansion of the more densely populated area.

(d) The study shall determine if a change of Location Class is needed. If needed, the patrols and leakage surveys shall immediately be adjusted to the intervals established by the operating company for the new Location Class.

(e) Needed changes in operating conditions and pipeline facilities operation shall be implemented within 18 months after the change in Location Class.

### PL-3.6.2 Confirmation or Revision of MAOP

If the study described in [para. PL-3.6.1](#) indicates that the established MAOP of a section of pipeline or main is not commensurate with the existing Location Class, and the section is in satisfactory physical condition, the MAOP of that section shall be confirmed or revised within 18 months following the Location Class change as follows:

(a) If the section involved has been previously tested in place for a period of not less than 2 h, the MAOP shall be confirmed or reduced so that it does not exceed that allowed in [Table PL-3.6.1-1](#) for design options A or B.

(b) If the previous test pressure was not high enough to allow the pipeline to retain its MAOP or to achieve an acceptable lower MAOP in the Location Class according to [\(a\)](#) above, the pipeline may either retain its MAOP or become qualified for an acceptable lower MAOP if it is retested at a

higher test pressure for a period of not less than 2 h in compliance with the applicable provisions of this Code. If the new strength test is not performed during the 18-month period following the Location Class change, the MAOP must be reduced so as to not exceed the design pressure commensurate with the requirements of [Table PL-3.6.1-1](#) for design options A or B at the end of the 18-month period. However, if the test is performed any time after the 18-month period has expired, the MAOP may be increased to the level it would have achieved if the test had been performed during that 18-month period.

(c) An MAOP that has been confirmed or revised according to [\(a\)](#) or [\(b\)](#) above shall not exceed that established by this Code. Confirmation or revision according to [para. PL-3.6.2](#) shall not preclude the application of [para. PL-3.14](#).

(d) Where operating conditions require that the existing MAOP be maintained, and the pipeline cannot be brought into compliance as provided in [\(a\)](#), [\(b\)](#), or [\(c\)](#) above, the pipe within the area of the Location Class change shall be replaced with pipe commensurate with the requirements of [Chapter PL-3](#), using the design factor obtained from [Table PL-3.7.1-1](#) or [Table PL-3.7.1-2](#) for the appropriate design option and Location Class.

### PL-3.6.3 Pressure-Relieving or Limiting Devices

Where the MAOP of a section of pipeline or main is lowered in accordance with [para. PL-3.6.2](#) and becomes less than the MAOP of the pipeline or main of which it is a part, a suitable unconfined pressure-relieving or pressure-limiting device shall be installed in accordance with provisions of [paras. PL-3.13.1](#) and [PL-3.13.2](#).

### PL-3.6.4 Review of Valve Locations

Where the study required in [para. PL-3.6.1](#) indicates that the Location Class has changed, the sectionalizing valve locations shall be reviewed to determine if access to the valves has been affected. Access routes to the valves shall be evaluated. The effects of evacuating the pipeline in the vicinity of the valves shall be determined. New routes and evacuation and valve location plans shall be developed as required.

### PL-3.6.5 Concentrations of People in Location Classes 1 and 2

(a) Where a facility such as a hospital, school, hotel, or recreational area of an organized character such as a sports facility, fairground, or amusement park is built near an existing steel pipeline in Location Class 1 or Class 2, consideration shall be given to the possible consequence of a failure, even though the probability of such an occurrence is very unlikely if the line is designed, constructed, and operated in accordance with this Code.

(1) Where such facility results in frequent concentrations of people, the requirements of [\(b\)](#) below shall apply.



(2) However, (b) below need not be applied if the facility is used so infrequently that the probability that the pipeline fails while it is occupied is acceptably low. This can be determined by a risk assessment carried out per para. PL-3.5.

(b) Pipelines near a place of public assembly as outlined in (a) above shall have a maximum allowable hoop stress not exceeding 40% SMYS, or the operating company may make the study described in para. PL-3.6.1(c) and determine that compliance with the following will result in an adequate level of safety:

(1) The segment is hydrostatically retested for at least 2 h to a minimum stress level of 100% of  $S_m$ .

(2) Patrols and leakage surveys are conducted at intervals consistent with those established by the operating company for Location Class 3.

(3) If any nearby facility is likely to encourage additional construction activity, provide appropriate pipeline markers.

## PL-3.7 STEEL PIPELINE

### (23) PL-3.7.1 Steel Piping Systems Design Requirements

(a) *Steel Pipe Design Formula.* The design pressure for steel gas piping systems or the nominal wall thickness for a given design pressure shall be determined by the following formula [for limitations, see (b) below]:

$$P = \frac{2St}{D} FETH_f$$

where

$D$  = nominal outside diameter of pipe

$E$  = longitudinal joint factor obtained from Mandatory Appendix IX, Table IX-3B

$F$  = design factor obtained from Table PL-3.7.1-1 or Table PL-3.7.1-2 as applicable, depending upon the fracture control option specified in (b) below used in the design. In setting the values of the design factor,  $F$ , due consideration has been given and allowance has been made for the various underthickness tolerances provided for in the pipe specifications listed and approved for usage in this Code.

$H_f$  = material performance factor from Mandatory Appendix IX, Table IX-5A. Material performance factors account for the adverse effects of hydrogen gas on the mechanical properties of carbon steels used in the construction of pipelines.

$P$  = design pressure, kPa (psig) [see also (b) below]  
 $S$  = SMYS, stipulated in the specifications under which the pipe was purchased from the manufacturer or determined in accordance with (d) below. The SMYS of some of the more commonly used pipeline steels whose specifications are incorpo-

rated by reference herein are tabulated for convenience in Mandatory Appendix IX, Table IX-1B.

$T$  = temperature derating factor obtained from Table PL-3.7.1-3

$t$  = nominal wall thickness

NOTE: See additional requirements for minimum wall thickness in (e) below.

(b) *Fracture Control and Arrest.* A fracture toughness criterion or other method shall be specified to control fracture propagation when a pipeline is designed to operate at a hoop stress over 40% of the SMYS. When a fracture toughness criterion is used, control shall be achieved by ensuring that the pipe has adequate ductility. Two options are provided on fracture control. Option A (prescriptive design method) shall be used with design factors,  $F$ , specified in Table PL-3.7.1-1. Option B (performance-based design method) shall be used with design factors,  $F$ , specified in Table PL-3.7.1-2 or with design factors specified in Table PL-3.7.1-1. The pipe material tensile requirements shall be specified on the purchasing specification and shall comply with the chemical and tensile requirements of API 5L Product Specification Level 2 (PSL2), with supplementary testing as follows:

(1) *Option A (Prescriptive Design Method).* The following requirements apply:

(-a) *Brittle Fracture Control.* To ensure that the pipe has adequate ductility, fracture toughness testing shall be performed in accordance with the testing procedures of Annex G of API 5L. These can be applied providing test specimens meet the minimum sizes given in Table 22 of API 5L. Toughness testing for brittle fracture control is not required for DN 100 (NPS 4) and smaller pipe. The test temperature shall be the colder of 0°C (32°F) or the lowest expected metal temperature during service or during pressure testing, if the latter is performed with air or gas, having regard to past recorded temperature data and possible effects of lower air and ground temperatures. The average shear value of the fracture appearance of three Charpy specimens from each heat shall not be less than 80% for full-thickness Charpy specimens, 85% for reduced-size Charpy specimens, or 40% for drop-weight tear testing specimens.

**Table PL-3.7.1-1**  
**Basic Design Factor,  $F$**   
**(Used With Option A)**

| Location Class               | Design Factor, $F$ |
|------------------------------|--------------------|
| Location Class 1, Division 2 | 0.50               |
| Location Class 2             | 0.50               |
| Location Class 3             | 0.50               |
| Location Class 4             | 0.40               |



**Table PL-3.7.1-2**  
**Basic Design Factor, F**  
**(Used With Option B)**

| Location Class               | Design Factor, F |
|------------------------------|------------------|
| Location Class 1, Division 2 | 0.72             |
| Location Class 2             | 0.60             |
| Location Class 3             | 0.50             |
| Location Class 4             | 0.40             |

(23) **Table PL-3.7.1-3**  
**Temperature Derating Factor, T, for Steel Pipe**

| Temperature, °C (°F)      | Temperature Derating Factor, T |
|---------------------------|--------------------------------|
| 121 or less (250 or less) | 1.000                          |
| 149 (300)                 | 0.967                          |
| 177 (350)                 | 0.933                          |
| 204 (400)                 | 0.900                          |
| 232 (450)                 | 0.867                          |

GENERAL NOTE: For intermediate temperatures, interpolate for derating factor.

(-b) *Ductile Fracture Arrest.* To ensure that the pipeline has adequate toughness to arrest a ductile fracture, the pipe shall be tested in accordance with Annex G of API 5L. This can be applied providing test specimens meet the minimum sizes given in Table 22 of API 5L. Toughness testing for ductile fracture control is not required for DN 100 (NPS 4) and smaller pipe. The test temperature shall be the colder of 0°C (32°F) or the lowest expected metal temperature during service. The average of the Charpy energy values from each heat shall meet or exceed the requirements specified by the following equation:

$$CVN = 0.008(RT)^{0.39} \sigma_h^2$$

where

CVN = full-size specimen CVN energy, ft-lb

R = radius of pipe, in.

T = nominal pipe wall thickness, in.

$\sigma_h$  = hoop stress due to design pressure, ksi

(-c) *Pipe Strength.* Maximum ultimate tensile strength of the pipe shall not exceed 690 MPa (100 ksi).

(-d) *Weld Metal Strength.* Maximum ultimate tensile strength of the weld metal shall not exceed 690 MPa (100 ksi).

(-e) *Yield Strength.* Minimum specified yield strength shall not exceed 480 MPa (70 ksi).

(-f) *Charpy Tests.* Weld procedure shall be qualified by Charpy tests. Three specimens from weld metal and three specimens from HAZ shall be tested at test temperature specified in (b)(1)(-b) above. Minimum

Charpy energy per specimen fracture area of each specimen shall meet the following criteria:

(-1) 27 J (20 ft-lb) for full-size CVN specimens or 218 J (161 ft-lb/in.<sup>2</sup>) for subsize CVN specimens for pipe up to DN 1400 (NPS 56)

(-2) 42 J (30 ft-lb) for full-size CVN specimens or 328 J (242 ft-lb/in.<sup>2</sup>) for subsize CVN specimens for pipe larger than DN 1400 (NPS 56)

(2) *Option B (Performance-Based Design Method).* The following requirements apply:

(-a) The pipe and weld material shall be qualified for adequate resistance to fracture in hydrogen gas at or above the design pressure and at ambient temperature using the applicable rules provided in Article KD-10 of ASME BPVC, Section VIII, Division 3, except as shown below.

(-1) The purpose of this test is to qualify the construction material by testing three heats of the material. The threshold stress intensity values,  $K_{IH}$ , shall be obtained from the thickest section from each heat of the material and heat treatment. The test specimens shall be in the final heat-treated condition (if applicable) to be used in pipe manufacturing. A set of three specimens shall be tested from each of the following locations: the base metal, the weld metal, and the HAZ of welded joints, welded with the same qualified WPS as intended for the piping manufacturing. A change in the welding procedure requires retesting of welded joints (weld metal and HAZ). The test specimens shall be in the TL direction. If TL specimens cannot be obtained from the weld metal and the HAZ, then LT specimens may be used. The values of  $K_{IH}$  shall be obtained by use of the test method described in KD-1040. The lowest measured value of  $K_{IH}$  shall be used in the pipeline design analysis.

(-2) When using Option B, the material performance factor,  $H_f$ , used in (a) shall be 1.0.

(-3) The values obtained in (-1) above may be used for other pipes manufactured from the same material specification/grade or similar specification/grade having the same nominal chemical composition as defined in Table PL-3.7.1-4 and same heat treatment condition, providing its tensile and yield strengths do not exceed the values of the material used in the qualification tests by more than 5%. The welded joints shall meet the requirements of the WPS used for qualifying the construction material.

(-4) Calculate maximum  $K_{IA}$  required at design pressure for the following elliptical surface crack. Where  $K_{IA}$  is the applied stress intensity factor, the critical crack size is developed by applicable fatigue loading. Fatigue design rules specified in Article KD-10 shall be used, or depth =  $t/4$ , length =  $1.5t$ , where  $t$  is the pipe wall thickness. In lieu of measuring fatigue crack growth rate (FCGR) properties as required in Article KD-10, the following properties may be used for fatigue analysis per KD-1010. The following FCGR properties are only applicable

**Table PL-3.7.1-4**  
**Nominal Chemical Composition Within a Specification/Grade**

| Material Specification/Grade<br>(Same Nominal Chemical Composition) | Carbon Content, % | Sulfur Content, % |
|---|-------------------|-------------------|
| <b>C-Mn Steels</b>  |                   |                   |
| A1  | ≤0.10             | ≤0.005            |
| A2  | ≤0.10             | >0.005 but ≤0.010 |
| A3  | >0.10 but ≤0.20   | ≤0.005            |
| A4  | >0.10 but ≤0.20   | >0.005 but ≤0.010 |
| A5  | >0.20             | ≤0.005            |
| A6  | >0.20             | >0.005 but ≤0.010 |
| <b>C-Mn-Microalloy Steels (HSLA)</b>                                |                   |                   |
| B1  | ≤0.12             | ≤0.007            |
| B2  | ≤0.12             | >0.007 but ≤0.010 |
| B3  | >0.12 but ≤0.20   | ≤0.007            |
| B4  | >0.12 but ≤0.20   | >0.007 but ≤0.010 |
| B5  | >0.20             | ≤0.007            |
| B6  | >0.20             | >0.007 but ≤0.010 |

for carbon steels in gaseous hydrogen service up to 20 MPa (3,000 psi):

(+a) Equation (1) shall be used for FCGR properties.<sup>1</sup>

$$\frac{da}{dN} = a_1 \Delta K^{b_1} + \left[ \left( a_2 \Delta K^{b_2} \right)^{-1} + \left( a_3 \Delta K^{b_3} \right)^{-1} \right]^{-1} \quad (1)$$

(+b) Equation (1) is applicable for carbon steel materials.

(+c) Equation (1) is applicable for design pressure not to exceed 20 MPa (3,000 psi).

(+d) Equation (1) is applicable for *R* ratio < 0.5. *R* ratio is defined in eq. (2).

$$R = K_{\min}/K_{\max} \quad (2)$$

where

*a*<sub>1</sub>, *b*<sub>1</sub>,

*a*<sub>2</sub>, *b*<sub>2</sub>,

*a*<sub>3</sub>, *b*<sub>3</sub> = constants (values are given in Table PL-3.7.1-5)

*da/dN* = crack growth rate, mm/cycle (in./cycle)

<sup>1</sup>Details of measurements and modeling that form the basis of this equation can be found in the following references:

(a) Slifka, A. J., Drexler, E. S., Amaro, R. L., Hayden, L. E., Stalheim, D. G., Lauria, D. S., and Hrabe, N. W. (2018). "Fatigue Measurement of Pipeline Steels for the Application of Transporting Gaseous Hydrogen." ASME Journal of Pressure Vessel Technology, 140 (1), 011407-1-011407-12.

(b) Amaro, R. L., White, R. M., Looney, C. P., Drexler, E. S., and Slifka, A. J. (2018). "Development of a Model for Hydrogen-Assisted Fatigue Crack Growth in Pipeline Steel." ASME Journal of Pressure Vessel Technology, 140 (2), 021403-1-021403-13.

*K*<sub>max</sub> = maximum applied stress intensity factor, MPa-√m (ksi√in.)

*K*<sub>min</sub> = minimum applied stress intensity factor, MPa-√m (ksi√in.)

Δ*K* = range of stress intensity factor, MPa-√m (ksi√in.)

(-5) Measure *K*<sub>IH</sub> in H<sub>2</sub> gas as specified in KD-1040. *K*<sub>IH</sub> is the threshold stress intensity factor.

(-6) *K*<sub>IH</sub> shall be equal to or higher than the calculated value of *K*<sub>IA</sub>. In any case, *K*<sub>IH</sub> shall not be less than 50 ksi·√in.

(-b) Phosphorus content of pipe material shall not exceed 0.015% by weight. The pipe material shall be manufactured with inclusion shape controlled practices.

(-c) Pipe material shall meet all applicable rules of API 5L, PSL 2. (See [Nonmandatory Appendix G](#) for a guideline to obtain higher toughness material.)

(-d) Brittle fracture control: all rules specified in (b)(1)(-a) above shall be met.

(-e) Ductile fracture arrest: all rules specified in (b)(1)(-b) shall be met.

(-f) Maximum ultimate tensile strength of the pipe shall not exceed 760 MPa (110 ksi).

(-g) Maximum ultimate tensile strength of the weld metal shall not exceed 760 MPa (110 ksi).

(-h) Minimum specified yield strength shall not exceed 550 MPa (80 ksi).

(c) *Limitations on Design Pressure, P, in (a).* The design pressure obtained by the formula in (a) shall be reduced to conform to the following: *P* shall not exceed 85% of the mill test pressure for all pipes in the pipeline, provided, however, that pipe, mill tested to a pressure less than 85% of the pressure required to produce a hoop stress equal to

**Table PL-3.7.1-5**  
**Material Constants for Fatigue Crack Growth Rate,**  
 **$da/dN$**

| Material Constant | Values      |                |
|-------------------|-------------|----------------|
|                   | SI          | U.S. Customary |
| $a_1$             | 4.0812 E-09 | 2.1746 E-10    |
| $b_1$             | 3.2106      | 3.2106         |
| $a_2$             | 4.0862 E-11 | 2.9637 E-12    |
| $b_2$             | 6.4822      | 6.4822         |
| $a_3$             | 4.8810 E-08 | 2.7018 E-09    |
| $b_3$             | 3.6147      | 3.6147         |

the specified minimum yield, may be retested with a mill type hydrostatic test or tested in place after installation. In the event the pipe is retested to a pressure in excess of the mill test pressure, then  $P$  shall not exceed 85% of the retest pressure rather than the initial mill test pressure. It is mandatory to use a liquid as the test medium in all tests in place after installation where the test pressure exceeds the mill test pressure. This paragraph is not to be construed to allow an operating pressure or design pressure in excess of that provided for by (a).

(d) *Limitations on SMYS,  $S$ , in (a)*

(1) When pipe that has been cold worked for meeting the SMYS is subsequently heated to a temperature higher than 482°C (900°F) for any period of time or over 315°C (600°F) for more than 1 h, the maximum allowable pressure at which it can be used shall not exceed 75% of the value obtained by use of the steel pipe design formula given in (a).

(2) In no case where the Code refers to the specified minimum value of a mechanical property shall the higher actual value of a property be substituted in the steel pipe design formula given in (a). If the actual value is less than the specified minimum value of a mechanical property, the actual value may be used, when it is permitted by the Code.

(e) *Additional Requirements for Nominal Wall Thickness,  $t$ , in (a)*

(1) The nominal wall thickness,  $t$ , required for pressure containment as determined by (a) may not be adequate for other forces to which the pipeline may be subjected (see para. PL-3.1.1). Consideration shall also be given to loading due to transportation or handling of the pipe during construction, weight of water during testing, and soil loading and other secondary loads during operation, such as earthquake or soil/ground movements. See para. PL-3.7.3(d) for suggested methods to provide additional protection. Consideration should also be given to welding or mechanical joining requirements. Standard wall thickness, as prescribed in ASME B36.10M, shall be the least nominal wall thickness used for pipe DN 100 (NPS 4) and below. Pipe sizes above DN 100 (NPS 4) shall have a wall thickness of at least 6.4 mm (0.25 in.).

(2) Transportation, installation, or repair of pipe shall not reduce the wall thickness at any point to a thickness less than 87.5% of the nominal wall thickness as determined by (a) for the design pressure to which the pipe is to be subjected.

(f) *Design Factors,  $F$ , and Location Classes.* The design factor in Table PL-3.7.1-1 shall be used for the designated Location Class when using the Option A methodology. All exceptions to basic design factors to be used in the design formula for Option A methodology are given in Table PL-3.7.1-6. The design factor in Table PL-3.7.1-2 shall be used for the designated Location Class when using the Option B methodology. All exceptions to basic design factors to be used in the design formula for Option B methodology are given in Table PL-3.7.1-7.

### PL-3.7.2 Protection of Pipelines and Mains From Hazards

(a) When pipelines and mains must be installed where they will be subject to natural hazards, such as washouts, floods, unstable soil, landslides, earthquake-related events (such as surface faulting, soil liquefaction, and soil and slope instability characteristics), or other conditions that may cause serious movement of, or abnormal loads on, the pipeline, reasonable precautions shall be taken to protect the pipeline, such as increasing the wall thickness, constructing revetments, preventing erosion, and installing anchors.

(b) Where pipelines and mains cross areas that are normally underwater or subject to flooding (i.e., lakes, bays, or swamps), sufficient weight or anchorage shall be applied to the line to prevent flotation.

(c) Because submarine crossings may be subject to washouts due to the natural hazards of changes in the waterway bed, water velocities, deepening of the channel, or changing of the channel location in the waterway, design consideration shall be given to protecting the pipeline or main at such crossings. The crossing shall be located in the more stable bank and bed locations. The depth of the line, location of the bends installed in the banks, wall thickness of the pipe, and weighting of the line shall be selected based on the characteristics of the waterway.

(d) Where pipelines and mains are exposed, such as at spans, trestles, and bridge crossings, the pipelines and mains shall be reasonably protected by distance or barricades from accidental damage by vehicular traffic or other causes.

**Table PL-3.7.1-6  
Design Factors for Steel Pipe Construction (Used With Option A)**

| Facility  | Design Factor by Location Class |      |      |      |
|---|---------------------------------|------|------|------|
|   | 1, Div. 2                       | 2    | 3    | 4    |
| Pipelines, mains, and service lines   | 0.50                            | 0.50 | 0.50 | 0.40 |
| Crossings of roads, railroads without casing:   |                                 |      |      |      |
| (a) Private roads   | 0.50                            | 0.50 | 0.50 | 0.40 |
| (b) Unimproved public roads   | 0.50                            | 0.50 | 0.50 | 0.40 |
| (c) Roads, highways, or public streets with hard surfaces, and railroads                                    | 0.50                            | 0.50 | 0.50 | 0.40 |
| Crossings of roads, railroads with casing:  |                                 |      |      |      |
| (a) Private roads   | 0.50                            | 0.50 | 0.50 | 0.40 |
| (b) Unimproved public roads   | 0.50                            | 0.50 | 0.50 | 0.40 |
| (c) Roads, highways, or public streets, with hard surface and railroads                                     | 0.50                            | 0.50 | 0.50 | 0.40 |
| Parallel encroachment of pipelines and mains on roads and railroads:  |                                 |      |      |      |
| (a) Private roads   | 0.50                            | 0.50 | 0.50 | 0.40 |
| (b) Unimproved public roads   | 0.50                            | 0.50 | 0.50 | 0.40 |
| (c) Roads, highways, or public streets with hard surfaces, and railroads                                    | 0.50                            | 0.50 | 0.50 | 0.40 |
| Fabricated assemblies   | 0.50                            | 0.50 | 0.40 | 0.40 |
| Pipelines on bridges  | 0.50                            | 0.50 | 0.50 | 0.40 |
| Pressure/flow control and metering facilities   | 0.50                            | 0.50 | 0.50 | 0.40 |
| Compressor station piping   | 0.50                            | 0.50 | 0.50 | 0.40 |
| Near concentration of people in Location Class 1, Class 2, or Class 3 (see <a href="#">para. PL-3.3.2</a> ) | 0.40                            | 0.40 | 0.40 | 0.40 |

**Table PL-3.7.1-7  
Design Factors for Steel Pipe Construction (Used With Option B)**

| Facility   | Design Factor by Location Class |      |      |      |
|--|---------------------------------|------|------|------|
|  | 1, Div. 2                       | 2    | 3    | 4    |
| Pipelines, mains, and service lines  | 0.72                            | 0.60 | 0.50 | 0.40 |
| Crossings of roads, railroads without casing:  |                                 |      |      |      |
| (a) Private roads  | 0.72                            | 0.60 | 0.50 | 0.40 |
| (b) Unimproved public roads  | 0.60                            | 0.60 | 0.50 | 0.40 |
| (c) Roads, highways, or public streets with hard surfaces, and railroads                       | 0.60                            | 0.50 | 0.50 | 0.40 |
| Crossings of roads, railroads with casing:   |                                 |      |      |      |
| (a) Private roads  | 0.72                            | 0.60 | 0.50 | 0.40 |
| (b) Unimproved public roads  | 0.72                            | 0.60 | 0.50 | 0.40 |
| (c) Roads, highways, or public streets with hard surfaces, and railroads                       | 0.72                            | 0.60 | 0.50 | 0.40 |
| Parallel encroachment of pipelines and mains on roads and railroads:                           |                                 |      |      |      |
| (a) Private roads  | 0.72                            | 0.60 | 0.50 | 0.40 |
| (b) Unimproved public roads  | 0.72                            | 0.60 | 0.50 | 0.40 |
| (c) Roads, highways, or public streets with hard surfaces, and railroads                       | 0.60                            | 0.60 | 0.50 | 0.40 |
| Fabricated assemblies  | 0.60                            | 0.60 | 0.50 | 0.40 |
| Pipelines on bridges   | 0.60                            | 0.60 | 0.50 | 0.40 |
| Pressure/flow control and metering facilities  | 0.60                            | 0.60 | 0.50 | 0.40 |
| Compressor station piping  | 0.50                            | 0.50 | 0.50 | 0.40 |
| Near concentration of people in Location Classes 1 and 2 (see <a href="#">para. PL-3.3.2</a> ) | 0.50                            | 0.50 | 0.50 | 0.40 |

(23) **PL-3.7.3 Cover, Clearance, and Casing Requirements for Buried Steel Pipelines and Mains**

(a) *Cover Requirements for Mains.* Buried mains shall be installed with a cover not less than 910 mm (36 in.). Where this cover provision cannot be met or where external loads may be excessive, the main shall be encased, bridged, or designed to withstand any such anticipated external loads. Where farming or other operations might result in deep plowing; in areas subject to erosion; or in locations where future grading is likely, such as road, highway, railroad, and ditch crossings; additional protection shall be provided [see (d) below for suggested methods to provide additional protection].

(1) Buried pipelines shall be installed with a cover not less than 910 mm (36 in.) for normal excavation, or not less than 610 mm (24 in.) for rock excavation. Minimum cover in agricultural areas shall be not less than 1 220 mm (48 in.).

(2) When considering converting an existing pipeline transporting other fluids to hydrogen gas transmission services, a depth of cover survey shall be performed to ensure that the existing pipeline has cover that meets the requirements of this section. Although depth of cover of 1 220 mm (48 in.) is preferred in agricultural areas, any converted pipeline in agricultural areas must have a minimum of 910 mm (36 in.) of cover, provisions must be made to lower the pipeline to provide this minimum cover, or additional cover may be added provided that it remain in place throughout the operation of the pipeline.

(b) *Clearance Between Pipelines or Mains and Other Underground Structures.* There shall be at least 460 mm (18 in.) of clearance between any buried pipeline and any other underground structure not used in conjunction with the pipeline. When such clearance cannot be attained, precautions to protect the pipe shall be taken, such as the installation of casing, bridging, or insulating material.

(c) *Casing Requirements Under Railroads, Highways, Roads, or Streets.* Casings shall be designed to withstand the superimposed loads. Where there is a possibility of water entering the casing, the ends of the casing shall be sealed. If the end sealing is of a type that will retain the MAOP of the carrier pipe, the casing shall be designed for this pressure with a design factor matching the carrier pipe. Casing vents should be installed, and they should be protected from the weather to prevent water from entering the casing. Requirements for crossings within casing of railroads and highways are shown in [Table PL-3.7.1-6](#).

(d) *Additional Underground Pipe Protection.* The pipe design factor,  $F$ , shall be in accordance with [Table PL-3.7.1-6](#) for the crossing of roads and railroads. The guidance provided by API RP 1102, GRI Report No.

91/0284, or Gas Piping Technology Committee's Guide Material Appendix G-15 may be considered for design and installation of pipeline crossing. The pipeline operator shall evaluate the need for extending additional pipe protection over the pipeline when the road or railroad right-of-way width is undefined, based on anticipated loading from traffic or heavy equipment performing maintenance activities adjacent to the road or railroad. Varying degrees of additional protection from third-party damage to a buried main or pipeline crossing within (or parallel to) the right-of-way of road or railroad may be achieved using the following techniques, or variants thereof, singly or in combination:

(1) A physical barrier or marker may be installed above or around the pipe [see [para. GR-5.12.2\(d\)](#)]. If a physical barrier is used, the potential conflict with the right-of-way maintenance activities should be recognized. Physical barrier or marker methods include

(-a) a concrete or steel barrier placed above the pipe

(-b) a concrete slab placed vertically adjacent to the pipe on each side and extended above the top of pipe elevation

(-c) damage-resistant coating material, such as concrete

(-d) extra depth of cover additional to that required in (a)(1) above

(-e) buried high-visibility warning tape placed parallel to and above the pipe

(-f) pipe casing [see (c) above]

(2) A heavier wall thickness than is required by the pipe design factor,  $F$ , in accordance with [Table PL-3.7.1-1](#) or [Table PL-3.7.1-6](#), may be used.

(3) Pipeline alignment should be as straight and perpendicular to the road or railroad alignment as possible, to promote reliable marking of the pipe location through the right-of-way and at the right-of-way limits. Additional underground pipe protection shall be used in conjunction with an effective educational program [see [para. GR-5.2.2\(d\)](#)], continuing surveillance of pipelines (see [para. GR-5.12.1](#)), pipeline patrolling (see [para. GR-5.12.2](#)), and utilization of programs that provide notification to operators regarding impending excavation activity, if available.

**PL-3.7.4 Installation of Steel Pipelines and Mains — Construction Specifications**

All construction work performed on piping systems in accordance with the requirements of this Code shall be done in accordance with construction specifications that shall cover all phases of the work, and shall be in sufficient detail to cover the requirements of this Code.



**Table PL-3.7.5-1  
Maximum Degree of Bending**

| Nominal Pipe Size | Deflection of Longitudinal Axis, deg  | Minimum Radius of Bend in Pipe Diameters |
|-------------------|---------------------------------------|--|
| Smaller than 12   | See <a href="#">para. PL-3.7.5(a)</a> | 18D                                      |
| 12                | 3.2                                   | 18D                                      |
| 14                | 2.7                                   | 21D                                      |
| 16                | 2.4                                   | 24D                                      |
| 18                | 2.1                                   | 27D                                      |
| 20 and larger     | 1.9                                   | 30D                                      |

### PL-3.7.6 Pipe Surface Requirements Applicable to Pipelines and Mains to Operate at a Hoop Stress of 20% or More of the SMYS

Gouges, grooves, and notches have been found to be an important cause of pipeline failures, and all harmful defects of this nature must be prevented, eliminated, or repaired. Precautions shall be taken during manufacture, hauling, and installation to prevent the gouging or grooving of pipe.

#### (a) Detection of Gouges and Grooves

(1) Examination shall be made to determine that the coating machine does not cause harmful gouges or grooves.

(2) Lacerations of the protective coating shall be carefully examined prior to the repair of the coating to determine if the pipe surface has been damaged.

(3) Field examination of uncoated pipe shall ensure that gouged or grooved pipe will not get into the finished pipeline or main.

#### (b) Field Repair of Gouges and Grooves

(1) Injurious gouges or grooves shall be removed.

(2) Gouges or grooves may be removed by grinding to a smooth contour, provided that the resulting wall thickness is not less than the minimum prescribed by this Code for the conditions of usage [see [para. PL-3.7.1\(b\)\(5\)\(-b\)](#)].

(3) When the conditions outlined in (2) above cannot be met, the damaged portion of pipe shall be cut out as a cylinder and replaced. Insert patching is prohibited.

#### (c) Dents

(1) A dent may be defined as a depression that produces a gross disturbance in the curvature of the pipe wall (as opposed to a scratch or gouge, which reduces the pipe wall thickness). The depth of a dent shall be measured as the gap between the lowest point of the dent and a prolongation of the original contour of the pipe in any direction.

(2) A dent, as defined in (1) above, which contains a stress concentrator such as a scratch, gouge, groove, or arc burn, shall be removed by cutting out the damaged portion of the pipe as a cylinder.

(3) All dents that affect the curvature of the pipe at the longitudinal weld or any circumferential weld shall be removed. All dents that exceed a maximum depth of 6.35 mm ( $\frac{1}{4}$  in.) in pipe DN 300 (NPS 12) and smaller or 2% of the nominal pipe diameter in all pipe greater than DN 300 (NPS 12) shall not be permitted in pipelines or mains intended to operate at hoop stress levels of 40% or more of the SMYS. When dents are removed, the damaged portion of the pipe shall be cut out as a cylinder. Insert patching and pounding out of the dents is prohibited.

### (23) PL-3.7.5 Bends, Elbows, and Miters in Steel Pipelines and Mains

(a) Changes in direction and orientation may be made by the use of bends, elbows, or miters under the following limitations:

(1) A bend shall be free from buckling, cracks, or other evidence of mechanical damage.

(2) The maximum degree of bending on a field cold bend may be determined by either method in [Table PL-3.7.5-1](#). The first column expresses the maximum deflection in an arc length equal to the nominal outside diameter, and the second column expresses the minimum radius as a function of the nominal outside diameter.

(3) A field cold bend may be made to a shorter minimum radius than permitted in (a)(2) above, provided the completed bend meets all other requirements of this section and the wall thickness after bending is not less than the minimum permitted by [para. PL-3.7.1\(a\)](#). This may be demonstrated through appropriate testing. Note that cold bending may make line pipe more susceptible to the effects of hydrogen embrittlement.

(4) For pipe smaller than DN 300 (NPS 12), the requirements of (a)(1) above must be met, and the wall thickness after bending shall not be less than the minimum permitted by [para. PL-3.7.1\(a\)](#). This may be demonstrated through appropriate testing.

(5) Hot bends made on cold worked or heat treated pipe shall be designed for lower stress levels in accordance with [para. PL-3.7.1\(b\)\(4\)](#).

(b) Factory-made, wrought-steel welding elbows or transverse segments cut therefrom may be used for changes in direction, provided that the arc length measured along the crotch is at least 25 mm (1 in.) on pipe sizes DN 50 (NPS 2) and larger.

*(d) Notches and Arc Burns*

(1) Notches on the pipe surface can be caused by mechanical damage in manufacture, transportation, handling, or installation, and when determined to be mechanically caused, shall be treated the same as gouges and grooves in (a) above.

(2) Stress concentrations that may or may not involve a geometrical notch may also be created by a process involving thermal energy in which the pipe surface is heated sufficiently to change its mechanical or metallurgical properties. These imperfections are termed "metallurgical notches." Examples include an arc burn produced by accidental contact with a welding electrode or a grinding burn produced by excessive force on a grinding wheel. Metallurgical notches may result in even more severe stress concentrations than a mechanical notch and shall be prevented or eliminated in all pipelines intended to operate at hoop stress levels of 20% or more of the SMYS.

(3) Arc burns shall be eliminated as follows:

(-a) The metallurgical notch caused by arc burns shall be removed by grinding, provided the grinding does not reduce the remaining wall thickness to less than the minimum prescribed by this Code for the conditions of use.

(-b) In all other cases, repair is prohibited, and the portion of pipe containing the arc burn must be cut out as a cylinder and replaced with a good piece. Insert patching is prohibited. Care shall be exercised to ensure that the heat of grinding does not produce a metallurgical notch.

(-c) Complete removal of the metallurgical notch created by an arc burn can be determined as follows: after visible evidence of the arc burn has been removed by grinding, swab the ground area with a 20% solution of ammonium persulfate. A blackened spot is evidence of a metallurgical notch and indicates that additional grinding is necessary.

### **PL-3.7.7 Miscellaneous Operations Involved in the Installation of Steel Pipelines and Mains**

(a) *Handling, Hauling, and Stringing.* Care shall be taken in the selection of the handling equipment and in handling, hauling, unloading, and placing the pipe so as not to damage the pipe.

(b) *Installation of Pipe in the Ditch.* On pipelines operating at hoop stress levels of 20% or more of the SMYS, it is important that stresses imposed on the pipeline by construction be minimized. The pipe shall fit the ditch without the use of external force to hold it in place until the backfill is completed. When long sections of pipe that have been welded alongside the ditch are lowered in, care shall be exercised so as not to jerk the pipe or impose any strains that may kink or put a permanent bend in the pipe. Slack loops are not prohibited by this paragraph where laying conditions render their use advisable.

*(c) Backfilling*

(1) Backfilling shall be performed in a manner to provide firm support under the pipe.

(2) If there are large rocks in the material to be used for backfill, care shall be used to prevent damage to the coating by such means as the use of rock-shield material, by making the initial fill with rock-free material sufficient to prevent damage, or by installing a protective coating on the pipe to prevent damage from rocks or other debris.

(3) Where the trench is flooded to consolidate the backfill, care shall be exercised to see that the pipe is not floated from its firm bearing on the trench bottom.

### **PL-3.8 HOT TAPS**

(23)

A hot tap shall not be considered a routine procedure, but shall be used only when there is no practical alternative. A hot-tap thermal analysis program shall be used to review, analyze, and provide the product flow and weld parameters during the hot tap. Examples of conditions where hot tapping is not permitted are as follows:

(a) with a pipe wall thickness less than 6.35 mm (0.250 in.)

(b) if the hardness of the pipeline is measured greater than 225 BHN (Brinell hardness number)

(c) where the hot-tap fitting will not have a clearance greater than 75 mm (3 in.) from a girth weld

(d) in piping that has any type of internal lining or coating

(e) upstream of rotating or reciprocating equipment, unless the equipment is protected by a strainer or filter

### **PL-3.9 PRECAUTIONS TO PREVENT COMBUSTION OF HYDROGEN-AIR MIXTURES DURING CONSTRUCTION OPERATIONS**

#### **PL-3.9.1 Leakage Prevention**

Operations such as gas or electric welding and cutting with cutting torches cannot be safely performed on hydrogen gas pipelines, mains, or auxiliary equipment, unless all possibility of leakage of hydrogen into the work area is eliminated. The following procedures are recommended:

(a) removal of a pipe spool between the pressurized pipeline and the work area

(b) closure of two valves, with continuous monitoring of an open vent valve by means of a hydrogen gas detector (double block and bleed)

(c) closure of an integral double block and bleed valve, with continuous monitoring of the open body vent valve

(d) closure of a valve, and installation of a blind flange or spectacle blind on the downstream flange of the valve or

(e) use of a venturi air mover to draw hydrogen gas away from the work area



### PL-3.9.2 Purging of Pipelines

When a pipeline is to be placed in service, the air in it shall be displaced. In order to avoid the creation of a combustible mixture, a slug of inert gas shall be introduced between the hydrogen and air. The hydrogen gas flow shall then be continued without interruption until all the air and inert gas have been removed from the facility. The vented gases shall be monitored and the vent closed before any substantial quantity of hydrogen gas is released to the atmosphere. Dead-ended legs of the pipeline system that cannot be swept by inert gas must be pressure purged.

### PL-3.9.3 Accidental Ignition

Whenever the accidental ignition in the open air of hydrogen gas-air mixture might be likely to cause personal injury or property damage, precautions shall be taken. For example:

- (a) prohibit smoking and open flames in the area
- (b) install a metallic bond around the location of cuts in gas pipes to be made by means other than cutting torches
- (c) take precautions to prevent static electricity sparks
- (d) provide a fire extinguisher of appropriate size and type, in accordance with NFPA 10

## PL-3.10 TESTING AFTER CONSTRUCTION

### PL-3.10.1 Pipeline Testing

Pipeline systems shall be tested after construction to the requirements of this Code except for pretested fabricated assemblies, pretested tie-in sections, and tie-in connections. The circumferential welds of welded tie-in connections not pressure tested after construction shall be examined by radiographic, ultrasonic, or other nondestructive methods in accordance with [para. PL-3.19.2](#).

### PL-3.10.2 Test Required to Prove Strength of Pipelines and Mains

Pipelines shall be tested at a pressure of at least 150% of MAOP for at least 2 h. Water is the preferred medium.

### PL-3.10.3 Test Level

In selecting the test level, the designer or operating company should be aware of the provisions of [para. PL-3.6](#) and the relationship between test pressure and operating pressure when the pipeline experiences a future increase in the number of dwellings intended for human occupancy.

### PL-3.10.4 Crossings

Other provisions of this Code notwithstanding, pipelines and mains crossing highways and railroads may be tested in each case in the same manner and to the same pressure as the pipeline on each side of the crossing.

### PL-3.10.5 Location Classes 3 and 4

Air or inert gas testing may be used in Location Classes 3 and 4, provided that all of the following conditions apply:

- (a) The maximum hoop stress during the test is less than 50% of the SMYS in Location Class 3 and less than 40% of the SMYS in Location Class 4.
- (b) The maximum pressure at which the pipeline or main is to be operated does not exceed 80% of the maximum field test pressure used.
- (c) The pipe involved is new pipe having a longitudinal joint factor,  $E$ , in [Mandatory Appendix IX, Table IX-3B](#) of 1.00.

### PL-3.10.6 Records

The operating company shall maintain in its file, for the useful life of each pipeline and main, records showing the procedures used and the data developed in establishing its MAOP.

### PL-3.10.7 Leak Tests for Pipelines or Mains (23)

(a) Each pipeline and main shall be tested after construction and before being placed in operation to demonstrate that it does not leak. If the test indicates that a leak exists, the leak or leaks shall be located and eliminated.

(b) The test procedure used shall be capable of disclosing all leaks in the section being tested and shall be selected after giving due consideration to the volumetric content of the section and to its location. This requires the exercise of responsible and experienced judgment, rather than numerical precision.

(c) In all cases where a line is to be stressed in a strength proof test to a hoop stress level of 20% or more of the SMYS of the pipe, and gas or air is the test medium, a leak test of at least 10 min duration shall be made at a pressure in the range from 690 kPa (100 psi) to that required to produce a hoop stress of 20% of the minimum specified yield, or the entire length of the pipeline shall be examined with a hydrogen detector while the hoop stress is held at approximately 20% of the specified minimum yield.

(d) All testing of pipelines and mains after construction shall be done with due regard for the safety of employees and the public during the test. When air or inert gas is used, suitable steps shall be taken to keep persons not working on the testing operations out of the testing area when the hoop stress is first raised from 50% of the specified minimum yield to the maximum test stress, and until the pressure is reduced to the maximum operating pressure.

## PL-3.11 COMMISSIONING OF FACILITIES

### PL-3.11.1 Procedures

Written procedures shall be established for commissioning. Procedures shall consider the need to isolate the pipeline from other connected facilities and the transfer of the constructed pipeline to those responsible for its operation. Commissioning procedures, devices, and fluids shall be selected to ensure that nothing is introduced into the pipeline system that will be incompatible with the hydrogen gas to be transported, or with the materials in the pipeline components.

### PL-3.11.2 Cleaning and Drying Procedures

Consideration shall be given to the need for cleaning and drying the pipe and its components beyond that required for removal of the test medium.

### PL-3.11.3 Functional Testing of Equipment and Systems

As a part of commissioning, all pipeline and compressor station monitor and control equipment and systems shall be fully function-tested, especially including safety systems such as pig trap interlocks, pressure and flow monitoring systems, and emergency pipeline shutdown systems. Consideration should also be given to performing a final test of pipeline valves before the hydrogen gas is introduced, to ensure that each valve is operating correctly.

### PL-3.11.4 Start-Up Procedures and Introduction of Transported Hydrogen Gas

Written start-up procedures shall be prepared before introducing the transported hydrogen into the system and shall require the following:

- (a) the system be mechanically complete and operational
- (b) all functional tests be performed and accepted
- (c) all necessary safety systems be operational
- (d) operating procedures be available
- (e) a communications system be established
- (f) transfer of the completed pipeline system to those responsible for its operation

### PL-3.11.5 Documentation and Records

The following commissioning records shall be maintained as permanent records:

- (a) cleaning and drying procedures
- (b) cleaning and drying results
- (c) function-testing records of pipeline monitoring
- (d) control equipment systems
- (e) completed prestart checklist

## PL-3.12 PIPE-TYPE AND BOTTLE-TYPE HOLDERS

### PL-3.12.1 Pipe-Type Holders

A pipe-type holder shall be designed, installed, and tested in accordance with the provisions of this Code applicable to a pipeline installed in the same location and operated at the same maximum pressure.

### PL-3.12.2 Bottle-Type Holders

Bottle-type holders shall be located on land owned or under the exclusive control and use of the operating company.

### PL-3.12.3 Installation of Pipe-Type and Bottle-Type Holders (23)

(a) The storage site shall be entirely surrounded with fencing to prevent access by unauthorized persons.

(b) The minimum clearance between containers and the fenced boundaries of the site is fixed by the maximum operating pressure of the holder as follows:

(1) less than 7 MPa (1,000 psi), 7.6 m (25 ft)

(2) 7 MPa (1,000 psi) or more, 30 m (100 ft)

(c) The minimum distance between pipe containers or bottles shall be determined by the following formula:

$$C = \frac{3DPF}{K}$$

where

$C$  = minimum clearance between pipe containers or bottles, mm (in.)

$D$  = outside diameter of pipe container or bottle, mm (in.)

$F$  = design factor [see para. PL-3.7.1(a)]

$K$  = 6 895 for SI units

= 1,000 for U.S. Customary units

$P$  = maximum allowable operating pressure, kPa (psig)

(d) Bottles shall be buried with the top of each container below the normal frost line, but in no case closer than 610 mm (24 in.) to the surface. Pipe-type holders shall be tested in accordance with the provisions of para. PL-3.10.2 for a pipeline located in the same Location Class as the holder site, provided, however, that in any case where the test pressure will produce a hoop stress of 80% or more of the SMYS of the pipe, water shall be used as the test medium.

### PL-3.12.4 Special Provisions Applicable to Bottle-Type Holders Only

Bottle-type holders shall be designed according to ASME BPVC, Section VIII, Division 1.

### PL-3.12.5 General Provisions Applicable to Both Pipe-Type and Bottle-Type Holders

Provision shall be made to prevent the formation or accumulation of liquids in the holder, connecting piping, and auxiliary equipment that might cause corrosion or interfere with the safe operation of the storage equipment. Relief valves shall be installed in accordance with provisions of this Code that will have relieving capacity adequate to limit the pressure imposed on the filling line and thereby on the storage holder to 110% of the design pressure.

## PL-3.13 CONTROL AND LIMITING OF HYDROGEN GAS PRESSURE

### PL-3.13.1 Basic Requirement for Protection Against Accidental Overpressuring

Every pipeline, main, distribution system, customer's meter and connected facilities, compressor station, pipe-type holder, bottle-type holder, container fabricated from pipe and fittings, and all special equipment, if connected to a compressor or to a hydrogen gas source where the failure of pressure control or other causes might result in a pressure that would exceed the MAOP of the facility, shall be equipped with suitable pressure-relieving or pressure-limiting devices. Any device used for controlling the pressure of a hydrogen gas pipeline shall have a set point no greater than the MAOP of the pipeline.

### PL-3.13.2 Control and Limiting of Gas Pressure in Holders, Pipelines, and All Facilities That Might at Times Be Bottle Tight

(a) Suitable types of protective devices to prevent overpressuring of such facilities include

(1) spring-loaded relief valves of types meeting the provisions of ASME BPVC, Section VIII

(2) pilot-loaded backpressure regulators used as relief valves, so designed that failure of the pilot system or control lines will cause the regulator to open

(3) rupture disks of the type meeting the provisions of ASME BPVC, Section VIII, Division 1

(b) The MAOP for steel pipelines or mains is, by definition, the maximum operating pressure to which the pipeline or main may be subjected in accordance with the requirements of this Code. For a pipeline or main, the MAOP shall not exceed the least of the following three items:

(1) the design pressure (defined in [para. GR-1.5](#)) of the weakest element of the pipeline or main. Assuming that all fittings, valves, and other accessories in the line have an adequate pressure rating, the MAOP of a pipeline or main shall be the design pressure determined in accordance with [para. PL-3.7.1\(a\)](#) for steel.

(2) the pressure obtained by dividing the pressure to which the pipeline or main is tested after construction by 1.4.

(3) the maximum safe pressure to which the pipeline or main should be subjected based on its operating and maintenance history.

### PL-3.13.3 Control and Limiting of Hydrogen Gas Pressure in High-Pressure Steel Distribution Systems

(a) Each high-pressure distribution system or main, supplied from a source of hydrogen gas that is at a higher pressure than the MAOP for the system, shall be equipped with pressure regulating devices of adequate capacity and designed to meet the pressure, load, and other service conditions under which they will operate or to which they may be subjected.

(b) In addition to the pressure regulating devices prescribed in (a) above, a suitable method shall be provided to prevent accidental overpressuring of a high-pressure distribution system. Suitable types of protective devices to prevent overpressuring of high-pressure distribution systems include

(1) relief valves as prescribed in [paras. PL-3.13.2\(a\)\(1\)](#) and [PL-3.13.2\(a\)\(2\)](#).

(2) weight-loaded relief valves.

(3) a monitoring regulator installed in series with the primary pressure regulator.

(4) a series regulator installed upstream from the primary regulator and set to limit the pressure on the inlet of the primary regulator continuously to the MAOP of the distribution system or less.

(5) an automatic shutoff device installed in series with the primary pressure regulator and set to shut off when the pressure on the distribution system reaches the MAOP or less. This device must remain closed until manually reset. It should not be used where it might cause an interruption in service to a large number of customers.

(6) spring-loaded, diaphragm-type relief valves.

### PL-3.13.4 MAOP for High-Pressure Distribution Systems

This pressure shall be the maximum pressure to which the system can be subjected in accordance with the requirements of this Code. It shall not exceed either of the following:

(a) the design pressure of the weakest element of the system as defined in [para. GR-1.5](#)

(b) the maximum safe pressure to which the system should be subjected based on its operation and maintenance history

(23) **PL-3.13.5 Control and Limiting of the Pressure of Hydrogen Gas Delivered From High-Pressure Distribution Systems**

When the pressure of the hydrogen gas and the demand by the customer are greater than those applicable under the provisions of this paragraph, the requirements for control and limiting of the pressure of hydrogen gas delivered are included in [para. PL-3.13.3](#).

(a) If the MAOP of the distribution system is 410 kPa (60 psig) or less, and a service regulator having the following characteristics is used, no other pressure limiting device is required:

(1) a pressure regulator capable of reducing distribution line pressure to pressures recommended for household appliances

(2) a single port valve with orifice diameter no greater than that recommended by the manufacturer for the maximum gas pressure at the regulator inlet

(3) a valve seat made of resilient material designed to withstand abrasion of the hydrogen gas, impurities in gas, and cutting by the valve, and designed to resist permanent deformation when it is pressed against the valve port

(4) pipe connections to the regulator not exceeding DN 50 (NPS 2)

(5) the capability under normal operating conditions of regulating the downstream pressure within the necessary limits of accuracy and of limiting the buildup of pressure under no-flow conditions to no more than 50% over the normal discharge pressure maintained under flow conditions

(6) a self-contained service regulator with no external static or control lines

(b) If the MAOP of the distribution system is 410 kPa (60 psig) or less, and a service regulator not having all of the characteristics listed in (a) above is used, or if the gas contains materials that seriously interfere with the operation of service regulators, suitable protective devices shall be installed to prevent unsafe overpressuring of the customer's appliances, should the service regulator fail. Some of the suitable types of protective devices to prevent overpressuring of the customers' appliances are

(1) a monitoring regulator

(2) a relief valve

(3) an automatic shutoff device

These devices may be installed as an integral part of the service regulator or as a separate unit.

(c) If the MAOP of the distribution system exceeds 410 kPa (60 psig), suitable methods shall be used to regulate and limit the pressure of the gas delivered to the customer to the maximum safe value. Such methods may include the following:

(1) a service regulator having the characteristics listed in (a) above and a secondary regulator located upstream from the service regulator. In no case shall the secondary regulator be set to maintain a pressure

higher than 410 kPa (60 psi). A device shall be installed between the secondary regulator and the service regulator to limit the pressure on the inlet of the service regulator to 410 kPa (60 psi) or less in case the secondary regulator fails to function properly. This device may be either a relief valve or an automatic shutoff that shuts if the pressure on the inlet of the service regulator exceeds the set pressure [410 kPa (60 psi) or less] and remains closed until manually reset.

(2) a service regulator and a monitoring regulator set to limit to a maximum safe value the pressure of the gas delivered to the customer.

(3) a service regulator with a relief valve vented to the outside atmosphere, with the relief valve set to open so that the pressure of gas going to the customer shall not exceed a maximum safe value. The relief valve may be either built into the service regulator or may be a separate unit installed downstream from the service regulator. This combination may be used alone only in cases where the inlet pressure on the service regulator does not exceed the manufacturer's safe working pressure rating of the service regulator, and it is not recommended for use where the inlet pressure on the service regulator exceeds 860 kPa (125 psi). For higher inlet pressures, the method in (1) or (2) above should be used.

**PL-3.13.6 Requirements for Design of Pressure-Relief and Pressure-Limiting Installations**

(a) Pressure-relief or pressure-limiting devices except rupture disks shall

(1) be constructed of materials such that the operation of the device will not normally be impaired by corrosion of external parts by the atmosphere or internal parts by gas

(2) have valves and valve seats that are designed not to stick in a position that will make the device inoperative and result in failure of the device to perform in the manner for which it was intended

(3) be designed and installed so that they can be readily operated to determine if the valve is free, can be tested to determine the pressure at which they will operate, and can be tested for leakage when in the closed position

(b) Rupture discs shall meet the requirements for design as set out in ASME BPVC, Section VIII, Division 1.

(c) The discharge stacks, vents, or outlet ports of all pressure relief devices shall be located where gas can be discharged into the atmosphere without undue hazard. As it is likely that hydrogen will ignite spontaneously when released, consideration should be given to all exposures in the immediate vicinity when deciding on the location of a vent to atmosphere. API 521 should be used to determine a safe setback distance from hydrogen vents. The possibility of ignition may be reduced by injecting an inert gas into the vent stack. Where required



to protect devices, the discharge stacks or vents shall be protected with rain caps to preclude the entry of water. A permanent flare shall be installed if the presence of a flame at the stack or vent is considered unacceptable. A discharge rod welded to the vent must be extended above the gas discharge point so normal venting  $\text{GH}_2$  is always below the flammability point at the discharge rod tip for systems with static vent stacks where ignition of the vented  $\text{GH}_2$  is a concern.

(d) The size of the openings, pipe, and fittings located between the system to be protected and the pressure relieving device and the vent line shall be of adequate size to prevent hammering of the valve and to prevent impairment of relief capacity.

(e) Precautions shall be taken to prevent unauthorized operation of any stop valve that will make a pressure relief valve inoperative. This provision shall not apply to valves that will isolate the system under protection from its source of pressure. Acceptable methods for complying with this provision are as follows:

(1) Lock the stop valve in the open position. Instruct authorized personnel of the importance of not inadvertently leaving the stop valve closed and of being present during the entire period that the stop valve is closed so that they can lock it in the open position before they leave the location.

(2) Install duplicate relief valves, each having adequate capacity by itself to protect the system, and arrange the isolating valves or three-way valve so that mechanically it is possible to render only one safety device inoperative at a time.

(f) Precautions shall be taken to prevent unauthorized operation of any valve that will make pressure limiting devices inoperative. This provision applies to isolating valves, bypass valves, and valves on control or float lines that are located between the pressure limiting device and the system that the device protects. A method similar to (e)(1) above shall be considered acceptable in complying with this provision.

(g) When a monitoring regulator, series regulator, system relief, or system shutoff is installed at a district regulator station to protect a piping system from overpressuring, the installation shall be designed and installed to prevent any single incident, such as an explosion in a vault or damage by a vehicle, from affecting the operation of both the overpressure protective device and the district regulator (see [para. PL-3.15](#)). Special attention shall be given to control lines. All control lines shall be protected from falling objects, excavations by others, or other foreseeable causes of damage, and shall be designed and installed to prevent damage to any one control line from making both the district regulator and the overpressure protective device inoperative.

(h) Each pressure relief station, pressure limiting station, or group of such stations installed to protect a piping system or pressure vessel shall have sufficient ca-

capacity and shall be set to operate to prevent the pressure from exceeding the following levels:

(1) Other than in low-pressure distribution systems, the required capacity is at the MAOP plus 10%.

(2) For low-pressure distribution systems, the required capacity is a pressure that would cause the unsafe operation of any connected and properly adjusted gas burning equipment.

(3) When more than one pressure-regulating or compressor station feeds into the pipeline or distribution system and pressure relief devices are installed at such stations, the relieving capacity at the remote station may be taken into account in sizing the relief devices at each station. In doing this, however, the assumed remote relieving capacity must be limited to the capacity of the piping system to transmit gas to the remote location or to the capacity of the remote relief device, whichever is less.

(4) Where the safety device consists of an additional regulator that is associated with or functions in combination with one or more regulators in a series arrangement to control or limit the pressure in a piping system, suitable checks shall be made. These checks shall be conducted to determine that the equipment will operate in a satisfactory manner to prevent any pressure in excess of the established MAOP of the system, should any one of the associated regulators malfunction or remain in the wide-open position.

### PL-3.14 UPRATING

This section prescribes minimum requirements for uprating pipelines or mains to higher MAOPs.

(a) A higher MAOP established under this section may not exceed the design pressure of the weakest element in the segment to be uprated. It is not intended that the requirements of this Code be applied retroactively to such items as road crossings, fabricated assemblies, minimum cover, and valve spacings. Instead, the requirements for these items shall meet the criteria of the operating company before the uprating is performed.

(b) A plan shall be prepared for uprating that shall include a written procedure that will ensure compliance with each applicable requirement of this section.

(c) Before increasing the MAOP of a segment that has been operating at a pressure less than that determined by [para. PL-3.13.2\(b\)](#), the following investigative and corrective measures shall be taken:

(1) The design, initial installation, method, and date of previous testing, Location Classes, materials, and equipment shall be reviewed to determine that the proposed increase is safe and consistent with the requirements of this Code.

(2) The condition of the line shall be determined by leakage surveys, other field examinations, and examination of maintenance records.

(3) Repairs, replacements, or alterations disclosed to be necessary by (c)(1) and (c)(2) above shall be made prior to the uprating.

(d) A new test according to the requirements of this Code should be considered if satisfactory evidence is not available to ensure safe operation at the proposed MAOP.

(e) When gas upratings are permitted under (b) above, the gas pressure shall be increased in increments, with a leak survey performed after each incremental increase. The number of increments shall be determined by the operator after considering the total amount of the pressure increase, the stress level at the final MAOP, the known condition of the line, and the proximity of the line to other structures. The number of increments shall be sufficient to ensure that any leaks are detected before they can create a potential hazard. Potentially hazardous leaks discovered shall be repaired before further increasing the pressure. A final leak survey shall be conducted at the higher MAOP.

(f) The new MAOP shall not exceed the pressure allowed by the steel pipe design formula [para. PL-3.7.1(a)].

(g) Records for uprating, including each investigation required by this section, corrective action taken, and pressure test conducted, shall be retained as long as the facilities involved remain in service.

(h) The MAOP of steel pipelines or mains may be increased after compliance with (c) above and one of the following provisions:

(1) If the physical condition of the line as determined by (c) above indicates the line is capable of withstanding the desired higher operating pressure, is in general agreement with the design requirements of this Code, and has previously been tested to a pressure equal to or greater than that required by this Code for a new line for the proposed MAOP, the line may be operated at the higher MAOP.

(2) If the physical condition of the line as determined by (c) above indicates that the ability of the line to withstand the higher maximum operating pressure has not been satisfactorily verified or that the line has not been previously tested to the levels required by this Code for a new line for the proposed higher MAOP, the line may be operated at the higher MAOP if it shall successfully withstand the test required by this Code for a new line to operate under the same conditions.

(3) If the physical condition of the line as determined by (c) above verifies its capability of operating at a higher pressure, a higher MAOP may be established according to para. PL-3.13.2(b) using, as a test pressure, the highest pressure to which the line has been subjected, either in a strength test or in actual operation.

(4) If it is necessary to test a pipeline or main before it can be uprated to a higher MAOP, and if it is not practical to test the line either because of the expense or difficulties created by taking it out of service or because of other oper-

ating conditions, a higher MAOP may be established in Location Class 1 as follows:

(-a) perform the requirements of (c) above.

(-b) select a new MAOP consistent with the condition of the line and the design requirements of this Code, provided the new MAOP does not exceed 80% of that permitted for a new line to operate under the same conditions and the pressure is increased in increments as provided in (c) above

## PL-3.15 VALVES

### PL-3.15.1 Required Spacing of Valves

(a) Sectionalizing valves shall be installed in new transmission pipelines at the time of construction. When determining the sectionalizing valve spacing, primary consideration shall be given to locations that provide continuous accessibility to the valves. Other factors involve the conservation of gas, time to blow down the isolated section, continuity of gas service, necessary operating flexibility, expected future development within the valve spacing section, and significant natural conditions that may adversely affect the operation and security of the line.

(b) Notwithstanding the considerations in (a) above, the spacing between valves on a new transmission line shall not exceed the following:

(1) 32 km (20 mi) in areas of predominantly Location Class 1

(2) 24 km (15 mi) in areas of predominantly Location Class 2

(3) 16 km (10 mi) in areas of predominantly Location Class 3

(4) 8 km (5 mi) in areas of predominantly Location Class 4

(c) The spacing defined in (b) above may be adjusted slightly to permit a valve to be installed in a more accessible location, with continuous accessibility being the primary consideration.

(d) No valves shall be installed in a confined space or in a vault unless adequate ventilation is provided.

### PL-3.15.2 Spacing of Valves on Distribution Mains

Valves on distribution mains, whether for operating or emergency purposes, shall be installed in high-pressure distribution systems in accessible locations to reduce the time to shut down a section of main in an emergency. In determining the spacing of the valves, consideration should be given to the operating pressure and size of the mains and local physical conditions, as well as the number and type of consumers that might be affected by a shutdown.

### PL-3.15.3 Location of Valves

#### (a) Transmission System Valves

(1) Sectionalizing block valves shall be accessible and protected from damage and tampering. If a blowdown valve is involved, it shall be located where the gas can be blown to the atmosphere without undue hazard.

(2) Sectionalizing valves may be installed above ground, in a vault, or buried. In all installations, an operating device to open or close the valve shall be readily accessible to authorized persons. All valves shall be suitably supported to prevent settlement or movement of the attached piping.

(3) Blowdown valves shall be provided so that each section of pipeline between main-line valves can be blown down to open atmosphere only. The sizes and capacity of the connections for blowing down the line shall be such that under emergency conditions the section of line can be blown down as rapidly as is practicable.

(4) This Code does not require the use of automatic valves, nor does the Code imply that the use of automatic valves presently developed will provide full protection to a piping system. Their use and installation shall be at the discretion of the operating company.

#### (b) Distribution System Valves

(1) A valve shall be installed on the inlet piping of each regulator station controlling the flow or pressure of gas in a distribution system. The distance between the valve and the regulator or regulators shall be sufficient to permit the operation of the valve during an emergency, such as a large gas leak or a fire in the station.

(2) Valves on distribution mains, whether for operating or emergency purposes, shall be located in a manner that will provide ready access and facilitate their operation during an emergency. Where a valve is installed in a buried box or enclosure, only ready access to the operating stem or mechanism is implied. The box or enclosure shall be installed in a manner to avoid transmitting external loads to the main.

### PL-3.16 VAULT PROVISIONS FOR DESIGN, CONSTRUCTION, AND INSTALLATION OF PIPELINE COMPONENTS

(a) Valves and pressure control stations shall preferably be installed above ground. Where it is not desirable to install valves above ground, valves shall be placed in a concrete vault that has adequate ventilation. Vaults shall be used only when there is no other practicable alternative.

(b) Vaults for valves, pressure-relieving, pressure-limiting, or pressure-regulating stations, etc., shall be designed and constructed in accordance with the following provisions:

(1) Vaults shall be designed and constructed in accordance with good structural engineering practice to meet the loads that may be imposed on them.

(2) Sufficient working space shall be provided so that all of the equipment required in the vault can be properly installed, operated, and maintained.

(3) In the design of vaults for pressure-limiting, pressure-relieving, and pressure-regulating equipment, consideration shall be given to the protection of the installed equipment from damage, such as that resulting from an explosion within the vault that may cause portions of the roof or cover to fall into the vault.

(4) Where piping extends through the vault structure, provision shall be made to prevent the passage of gases or liquids through the opening and to avert strains in the piping. Equipment and piping shall be suitably sustained by metal, masonry, or concrete supports. The control piping shall be placed and supported in the vault so that its exposure to injury or damage is reduced to a minimum.

(5) Vault openings shall be located so as to minimize the hazards of tools or other objects falling on the regulator, piping, or other equipment. The control piping and the operating parts of the equipment installed shall not be located under a vault opening where workmen can step on them when entering or leaving the vault or pit, unless such parts are suitably protected.

(6) Whenever a vault opening is to be located above equipment that could be damaged by a falling cover, a circular cover should be installed or other suitable precautions should be taken.

(c) Accessibility shall be considered in selecting a site for a vault. Some of the important factors to consider in selecting the location of a vault are as follows:

(1) *Exposure to Traffic.* The location of vaults in street intersections or at points where traffic is heavy or dense should be avoided.

(2) *Exposure to Flooding.* Vaults should not be located at points of minimum elevation, near catch basins, or where the access cover will be in the course of surface waters.

(3) *Exposure to Adjacent Subsurface Hazards.* Vaults should be located as far as is practical from water, electric, steam, or other facilities.

(d) The top of the vault shall contain a ventilation system designed to prevent the buildup of hydrogen. Vents associated with the pressure-regulating or pressure-relieving equipment must not be connected to the vault ventilation.

#### (e) Drainage and Waterproofing

(1) Provisions shall be made to minimize the entrance of water into vaults. Nevertheless, vault equipment shall always be designed to operate safely if submerged.

(2) No vault containing hydrogen gas piping shall be connected by means of a drain connection to any other substructure, such as a sewer.

(3) Electrical equipment in vaults shall conform to the requirements of ANSI/NFPA 70.



### PL-3.17 LOCATION FOR CUSTOMERS' METER AND REGULATOR INSTALLATIONS

(a) All hydrogen gas metering and associated facilities shall be installed above grade and fully protected.

(b) Customers' meter installations shall not be used at a maximum operating pressure higher than the manufacturer's rating for the meter.

(c) Meter and regulator installations shall be protected from vandalism and damage.

(d) Meters and service regulators shall not be installed where rapid deterioration from corrosion or other causes is likely to occur, unless proven measures are taken to protect against such deterioration.

(e) A suitable protective device, such as a backpressure regulator or a check valve, shall be installed downstream of the meter under the following conditions:

(1) If the nature of the utilization equipment is such that it may induce a vacuum at the meter, install a backpressure regulator downstream from the meter.

(2) Install a check valve or equivalent if the utilization equipment might induce a backpressure or the gas utilization equipment is connected to a source of oxygen or compressed air.

(f) All service regulator vents and relief vents, where required, shall terminate in the outside air in rain- and insect-resistant fittings. The open end of the vent shall be located where the gas can escape freely into the atmosphere and away from any openings into the buildings if a regulator failure resulting in the release of gas occurs. At locations where service regulators might be submerged during floods, either a special antiflood type breather vent fitting shall be installed or the vent line shall be extended above the height of the expected flood waters.

(g) All meters and regulators shall be installed in such a manner as to prevent undue stresses on the connecting piping and/or the meter. Lead (Pb) connections or other connections made of material that can be easily damaged shall not be used. The use of standard weight close (all thread) nipples is prohibited.

### PL-3.18 HYDROGEN GAS SERVICE LINES

#### (23) PL-3.18.1 General Provisions Applicable to Steel Lines

(a) *Installation of Service Lines.* Service lines shall be installed at a depth that will protect them from excessive external loading and local activities, such as gardening, landscaping, etc. It is required that a minimum of 610 mm (24 in.) of cover be provided. Pipeline warning tape shall be placed 150 mm (6 in.) above the service line.

(b) *Types of Valves Suitable for Service Line Valves*

(1) Valves used as service line valves shall meet the applicable requirements of [para. PL-2.2.2](#).

(2) The use of soft seat service line valves is not recommended when the design of the valves is such that exposure to excessive heat could adversely affect the ability of the valve to prevent the flow of hydrogen gas.

(3) A valve incorporated in a meter bar that permits the meter to be bypassed does not qualify under this Code as a service line valve.

(4) Service line valves on service lines with pressure in excess of 410 kPa (60 psig), installed either inside buildings or in confined locations outside buildings where the blowing of gas would be hazardous, shall be designed and constructed to minimize the possibility of the removal of the core of the valve accidentally or willfully with ordinary household tools.

(5) The operating company shall make certain that the service line valves installed on high-pressure service lines are suitable for this use, either by making their own tests or by reviewing the tests made by the manufacturers.

(6) On service lines designed to operate at pressures in excess of 410 kPa (60 psig), the service line valves shall be the equivalent of a pressure lubricated valve or a needle type valve. Other types of valves may be used where tests by the manufacturer or by the user indicate that they are suitable for this kind of service.

(c) *Location of Service Line Valves*

(1) Service line valves shall be installed on all new service lines (including replacements) in a location readily accessible from the outside.

(2) Valves shall be located upstream of the meter if there is no regulator, or upstream of the regulator if there is one.

(3) All service lines operating at a pressure greater than 70 kPa (10 psig) and all service lines DN 50 (NPS 2) or larger shall be equipped with a valve located on the service line outside of the building, except that whenever gas is supplied to a theater, house of worship, school, factory, or other building where large numbers of persons assemble, an outside valve will be required, regardless of the size of the service line or the service line pressure.

(4) Underground valves shall be located in a covered durable curb box or standpipe designed to permit ready operation of the valve. The curb box or standpipe shall be supported independently of the service line.

(d) *Location of Service Line Connections to Main Piping.* It is recommended that service lines be connected to either the top or the side of the main. The connection to the top of the main is preferred to minimize the possibility of dust and moisture being carried from the main into the service line.

(e) *Testing of Service Lines After Construction.* Each service line shall be tested after construction and before being placed in service to demonstrate that it does not leak. The service line connection to the main need not be included in this test if it is not feasible to do so. Test requirements are as follows:

(1) Service lines to operate at a pressure of less than 7 kPa (1 psig), which do not have a protective coating capable of temporarily sealing a leak, shall be given a standup air or gas pressure test at not less than 70 kPa (10 psig) for at least 5 min.

(2) Service lines to operate at a pressure of less than 7 kPa (1 psig), which have a protective coating that might temporarily seal a leak, and all service lines to operate at a pressure of 7 kPa (1 psig) or more, shall be given a standup air or gas pressure test for at least 5 min at the proposed maximum operating pressure or 620 kPa (90 psig), whichever is greater. Service lines of steel, however, that are operating at hoop stress levels of 20% or more of the SMYS shall be tested in accordance with the requirements for testing mains. (See [para. PL-3.10.](#))

### (23) PL-3.18.2 Steel Service Lines

#### (a) Design of Steel Service Lines

(1) Steel pipe, when used for service lines, shall conform to the applicable requirements of [Chapter GR-2.](#)

(2) Steel service pipe shall be designed in accordance with the requirements of [para. PL-3.7.1.](#) Where the pressure is less than 690 kPa (100 psig), the steel service pipe shall be designed for at least 690 kPa (100 psig) pressure.

(3) Steel pipe used for service lines shall be installed in such a manner that the piping strain or external loading shall not be excessive.

(4) All underground steel service lines shall be joined by threaded and coupled joints, compression-type fittings, or by qualified welding or brazing methods, procedures, and operators.

#### (b) Installation of Steel Service Lines in Bores

(1) When coated steel pipe is to be installed as a service line in a bore, care shall be exercised to prevent damage to the coating during installation.

(2) When a service line is to be installed by boring or driving, and coated steel pipe is to be used, it shall not be used as the bore pipe or drive pipe and left in the ground as part of the service line unless it has been demonstrated that the coating is sufficiently durable to withstand the boring or driving operation in the type of soil involved without significant damage to the coating. Where significant damage to the coating may result from boring or driving, the coated service line should be installed in an oversized bore or casing pipe of sufficient diameter to accommodate the service pipe.

(c) *Coated Pipe.* In exceptionally rocky soil, coated pipe shall not be inserted through an open bore if significant damage to the coating is likely.

#### (d) Installation of Service Lines Into or Under Buildings

(1) Underground steel service lines, when installed below grade through the outer foundation wall of a building, shall be either encased in a sleeve or otherwise protected against corrosion. The service line and/or sleeve shall be sealed at the foundation wall to prevent entry of gas or water into the building.

(2) Steel service lines, where installed underground under buildings, shall be encased in a gas-tight conduit. When such a service line supplies the building it subtends, the conduit shall extend into a normally usable and accessible portion of the building. At the point where the conduit terminates, the space between the conduit and the service line shall be sealed to prevent the possible entrance of any gas leakage. The casing shall be vented at a safe location.

### PL-3.19 INSTALLATION INSPECTION

(23)

(a) Inspection shall conform to the applicable requirements of [section GR-1.5](#) and [Chapters GR-4](#) and [GR-6.](#)

(b) The installation inspection provisions for pipelines and other facilities to operate at hoop stresses of 20% or more of the SMYS shall be adequate to make possible the following examinations at sufficient intervals to ensure good quality of workmanship:

- (1) fit-up of the joints before the weld is made
- (2) root pass before subsequent weld passes are applied
- (3) completed welds before they are covered with coating
- (4) surface of the pipe for serious surface defects just prior to the coating operation [see [para. PL-3.7.6\(a\)\(2\)](#)]
- (5) condition of the ditch bottom just before the pipe is lowered in, except for offshore pipelines
- (6) surface of the pipe coating as it is lowered into the ditch to find coating scratches that indicate the pipe might have been damaged after being coated
- (7) fit of the pipe to the ditch before backfilling
- (8) repairs, replacements, or changes ordered before they are covered
- (9) special tests and examinations as are required by the specifications, such as nondestructive testing of welds and electrical testing of the protective coating
- (10) backfill material prior to use and observe backfill procedure to ensure no damage occurs to the coating in the process of backfilling

#### PL-3.19.1 Weld Examination Requirements

(23)

Examination of welds must be conducted by NDE personnel. [Chapter GR-4](#) applies. The following examination and tests for quality control of welds on hydrogen pipeline systems must be conducted:

- (a) Each weld shall be visually examined.
- (b) In addition, all butt welds shall be examined through radiographic examination or ultrasonic testing. Fillet and socket welds shall be examined by magnetic particle testing, or other comparable and acceptable methods of nondestructive testing. Each weld shall be examined over its entire circumference.
- (c) If a circumferential weld occurs in a bend section, or if postweld heat treating has been performed, nondestructive testing shall be done after these procedures.

**(23) PL-3.19.2 Visual Examination and Acceptance Criteria**

Quality control verifications and visual examinations shall be performed based on the following requirements. Visual examination shall be as defined in [Chapter GR-1](#). Visual examinations of welds and components shall be performed in accordance with ASME BPVC, Section V, Article 9, including the following:

(a) materials, components, and products shall satisfy the Quality Control examiner that they conform to specified requirements.

(b) 100% visual examination of all weldments and brazements.

(c) 100% visual examination of longitudinal weldments used for the fabrication of pipe and pipe components. This does not include the manufacturing of pipe or pipe components to a specification or standard.

(d) the assembly of threaded, bolted, and other joints shall satisfy the examiner that they conform to the applicable requirements of [para. PL-2.2](#). When leak testing is to be performed, all threaded, bolted, and other mechanical joints shall be examined.

(e) examination during erection of piping, including checking of alignment, supports, and cold spring.

(f) examination of erected piping for evidence of defects that would require repair or replacement, and for other evident deviations from the intent of the design.

(g) *Acceptance Criteria for Weldments.* NDE visual examination criteria shall be based on the requirements of API 1104 and the specified requirements of engineering design.

(h) *Acceptance Criteria for Brazements.* Final examination of brazements shall be performed based on the definition of visual examination. Visual examination shall include postbrazing cleaning of brazed deposit and affected base metal. The following indications, defects, or conditions are unacceptable:

- (1) cracks
- (2) lack of fill
- (3) voids in brazed deposit
- (4) porosity in brazed deposit
- (5) flux entrapment
- (6) noncontinuous fill
- (7) base metal dilution into brazed deposit
- (8) unsatisfactory surface appearance of the brazed deposit and base metal, caused by overheating resulting in porous and oxidized surfaces

**(23) PL-3.19.3 Radiographic Examination**

Radiographic examination shall be performed based on the following requirements:

(a) *Weldments and Components*

(1) Examinations shall be performed in accordance with API 1104 or ASME BPVC, Section V, Article 2, referencing ASTM E390 and ASTM E1648.

(2) When radiographic examination is required for complete joint penetration weldments (circumferential, longitudinal, branch, and miter joint connections), the full length or circumference of the weld shall be radiographed.

(3) Acceptance criteria shall be based on the requirements of API 1104 and the specific requirements of engineering design.

(b) *Brazements and Components.* The extent of radiographic examination and the acceptance criteria shall be specified by engineering design.

**PL-3.19.4 Liquid Penetrant Examination**

(23)

Liquid penetrant examination (for ferrous or nonferrous materials) shall be performed based on the following requirements:

(a) *Weldments and Components*

(1) Examinations shall be performed in accordance with ASME BPVC, Section V, Article 6.

(2) Liquid penetrant examination shall be performed on all welds connecting to hydrogen piping system components that are not radiographed.

(3) Other examinations shall be as specified by engineering design.

(4) Acceptance criteria shall be based on the requirements of API 1104 and the specific requirements of engineering design.

(b) *Brazements and Components.* The extent of liquid penetrant examination and the acceptance criteria shall be specified by engineering design.

**PL-3.19.5 Magnetic Particle Examination**

(23)

Magnetic particle examination (for ferrous materials) shall be performed based on the following requirements:

(a) *Weldments and Components*

(1) Examinations shall be performed in accordance with ASME BPVC, Section V, Article 7.

(2) Magnetic particle examination shall be performed on all welds connecting to hydrogen piping system components that are not radiographed.

(3) Other examinations shall be as specified by engineering design.

(4) Acceptance criteria shall be based on the requirements of API 1104 and the specific requirements of engineering design.

(b) *Brazements and Components.* The extent of magnetic particle examination and the acceptance criteria shall be specified by engineering design.

**PL-3.19.6 Ultrasonic Examination**

(23)

Ultrasonic examinations shall not be substituted for radiography. Ultrasonic examination shall be used when specified by engineering design and shall be performed based on the following requirements:

(a) Ultrasonic examination of welds shall be performed in accordance with API 1104 or ASME BPVC, Section V, Article 5.

(b) Acceptance criteria shall be based on API 1104.

### (23) PL-3.19.7 Hardness Control and Testing

Hardness testing shall be conducted for welding procedure qualification, hot and cold bent formed piping, pipe components, and production weldments.

(a) *Welding Procedure Qualifications.* Hardness testing for welding procedure qualification shall be performed in accordance with the requirements of [para. GR-3.10](#).

(b) *Production Weldments*

(1) Hardness testing shall be conducted on weldments as follows:

(-a) non-PWHT (as-welded condition) base metal Group P-1, carbon steel weldments made using SAW or FCAW process

(-b) non-PWHT (as-welded condition) weldments containing carbon steel filler metal with a minimum of 1.6% Mn

(-c) any weldments that have been subjected to PWHT

(2) The extent of hardness testing shall be based on the design criteria as follows:

(-a) MAOP < 40% SMYS: 5% random

(-b) MAOP ≥ 40% SMYS: 20% random

(-c) MAOP ≥ 14 MPa (2,000 psig) and all cyclic service conditions: 100%

(3) Hardness readings shall be taken with a portable hardness tester in accordance with ASTM A833 or ASTM E110. Other hardness testing techniques may be applied when specified by the engineering design.

(4) Hardness testing survey shall be performed as follows:

(-a) The minimum number of hardness test locations shall be based on pipe diameters: ≤NPS 6, one test required; >NPS 6 but ≤NPS 12, two tests required; >NPS 12, three tests required.

(-b) Testing at multiple locations shall be at equally spaced intervals of 0 deg, 90 deg, and 180 deg. The tests shall include weld metal and its corresponding HAZ on each side of the weld.

(-c) The maximum hardness is 237 BHN. Other hardness limits shall be as specified by the engineering design.

### PL-3.20 REPAIR OR REMOVAL OF DEFECTIVE WELDS IN PIPING INTENDED TO OPERATE AT HOOP STRESS LEVELS OF 20% OR MORE OF THE SMYS

Defective welds shall be repaired or removed. If a repair is made, it shall be in accordance with API 1104. Welders performing repairs shall be qualified in accordance with [para. GR-3.2.4](#).

### PL-3.21 STEEL PIPELINE SERVICE CONVERSIONS (23)

The intent of this section is to set out requirements to allow an operator of a pipeline previously used for service not covered by this Code to qualify that pipeline for service under this Code. For a dual service pipeline used alternately to transport natural gas under ASME B31.8 or hydrogen under this Code, only the initial conversion to hydrogen service requires qualification testing. The following procedure shall be followed:

(a) Carry out a risk assessment according to [para. PL-3.5](#), if the potential impact calculation [[para. PL-3.5\(a\)](#)] requires this.

(b) Prepare a written procedure outlining the steps to be followed during the study and conversion of the pipeline system. Note any unusual conditions relating to this conversion.

(c) Maintain for the life of the pipeline a record of the studies, inspections, tests, repairs, replacements, and alterations made in connection with conversion of the existing pipeline to hydrogen service under this Code.

(d) Study all available information on the original pipeline design, inspection, and testing. Particular attention should be paid to welding procedures used and other joining methods, internal and external coating, pipe, and other material descriptions.

(e) Study available operating and maintenance data, including leak records, inspections, failures, cathodic protection, and internal corrosion control practices.

(f) Consider the age of the pipeline and the length of time it may have been out of service.

(g) Examine all above-ground segments of the pipeline for physical condition. During the examination, identify the material, where possible, for comparison with available records.

(h) Establish the number of buildings near the pipeline or main intended for human occupancy and determine the design factor for each segment in accordance with [para. PL-3.2](#) and [Table PL-3.7.1-1](#).

(i) The MAOP shall be determined by the steel piping design formula in [para. PL-3.7.1\(a\)](#), taking into account any changes in Location Class since original construction. It shall not exceed 15.3 MPa (2,200 psi).

(j) The material performance factor,  $H_f$ , shall be determined from [Chapter GR-2](#) and the hydrostatic test data available, using the material description from the mill certificates, if these are in the owner's possession.

(k) If the original mill certificates are unavailable, the material description shall be determined by chemical and physical analysis of samples of the pipeline material. The sampling rate shall be one examination per 1.6 km (1 mi) of pipeline. The material performance factor,  $H_f$ , for a pipeline shall be the lowest value obtained from any of the samples.

(l) The pipe material shall be qualified to meet either Option A or Option B requirements for fracture control and arrest shown in [para. PL-3.7.1\(b\)](#). If the material

cannot be qualified, the MAOP shall be selected to limit hoop stress to 40% SMYS of the pipe at all points on the pipeline.

(m) An evaluation shall be carried out for any factors that may have caused a reduction in wall thickness during the operating life of the pipeline. These include imperfect cathodic protection, internal corrosion caused by products or contaminants being transported, and damage due to surface activities.

(n) Weld and base metal coupons shall be subject to laboratory analysis to assess the presence of weld inclusions (such as slag), hardness, yield strength, and ultimate tensile strength. A minimum of one sample per 1.6 km (1 mi) should be examined.

(o) If there is reason to believe that there has been a reduction in wall thickness since original construction, measurement of wall thickness along the length of the

pipeline shall be done using a suitable internal inspection device. The wall thickness,  $t$ , used in the steel piping design formula [see [para. PL-3.7.1\(a\)](#)] shall be the minimum wall thickness determined by the internal inspection. Alternatively, suitability of the pipeline may be evaluated by using the rules of ASME B31G.

(p) If internal inspection of the pipeline is not carried out, a hydrostatic test shall be performed. The test pressure to be used to confirm the MAOP calculated in [\(h\)](#) above shall be the test pressure obtained at the high elevation point of the minimum strength test section and shall not be higher than the pressure required to produce a stress equal to the yield strength as determined by testing.

(q) Determine that all valves, flanges, and other pressure-rated components have adequate ratings.

(r) The pipeline depth of cover is to be as stated in [para. PL-3.7.3](#).



# MANDATORY APPENDIX I

## DESIGN OF ABOVEGROUND HYDROGEN GAS PIPELINE FACILITIES

### I-1 COMPRESSOR STATIONS

#### I-1.1 Compressor Station Design

**I-1.1.1 Location of Compressor Building.** The main compressor building for hydrogen gas compressor stations shall be located at such clear distances from adjacent property not under control of the company as to minimize the hazard of communication of fire to the compressor building from structures on adjacent property. Sufficient open space should be provided around the building to permit the free movement of firefighting equipment.

**I-1.1.2 Building Construction.** All compressor station buildings that house hydrogen gas piping or equipment handling hydrogen gas shall be constructed of noncombustible or limited combustible materials.

**I-1.1.3 Exits.** A minimum of two exits shall be provided for each operating floor of a main compressor building, basements, and any elevated walkway or platform 3 m (10 ft) or more above ground or floor level. Individual engine catwalks shall not require two exits. Exits of each such building may be fixed ladders, stairways, etc. The maximum distance from any point on an operating floor to an exit shall not exceed 23 m (75 ft), measured along the centerline of aisles or walkways. Exits shall be unobstructed doorways located to provide a convenient possibility of escape and shall provide unobstructed passage to a place of safety. Door latches shall be of a type that can be readily opened from the inside without a key. All swinging doors located in an exterior wall shall swing outward.

**I-1.1.4 Fenced Areas.** Any fence that may hamper or prevent escape of persons from the vicinity of a compressor station in an emergency shall be provided with a minimum of two gates. These gates shall be located to provide a convenient opportunity for escape to a place of safety. Any such gates located within 61 m (200 ft) of any compressor plant building shall open outward and shall be unlocked (or capable of being opened from the inside without a key) when the area within the enclosure is occupied. Alternatively, other facilities affording a similarly convenient exit from the area may be provided.

#### I-1.2 Electrical Facilities

All electrical equipment and wiring installed in hydrogen gas transmission and distribution compressor stations shall conform to the requirements of NFPA 70, insofar as the equipment commercially available permits. Electrical installations located in hazardous areas, as defined in NFPA 70, and that are to remain in operation during compressor station emergency shutdown, as provided in [para. I-1.3.2.1\(a\)](#), shall be designed to conform to NFPA 70 for Class I, Division 1 requirements.

#### I-1.3 Compressor Station Equipment

**I-1.3.1 Fire Protection.** Fire protection facilities should be provided in accordance with the American Insurance Association's recommendations. If the fire pumps are a part of such facilities, their operation shall not be affected by emergency shutdown facilities.

##### I-1.3.2 Safety Devices

###### I-1.3.2.1 Emergency Shutdown Facilities

(23)

(a) Each transmission compressor station shall be provided with an emergency shutdown system by means of which the hydrogen gas can be blocked out of the station and the station hydrogen gas piping blown down. Operation of the emergency shutdown system also shall cause the shutdown of all hydrogen gas compressing equipment and all hydrogen gas fired equipment. Operation of this system shall deenergize the electrical facilities located in the vicinity of hydrogen gas headers and in the compressor room, except those that provide emergency lighting for personnel protection and those that are necessary for protection of equipment. The emergency shutdown system shall be operable from any one of at least two locations outside the hydrogen gas area of the station, preferably near exit gates in the station fence, but not more than 150 m (500 ft) from the limits of the stations. Blowdown piping shall extend to a location where the discharge of hydrogen gas is not likely to create a hazard to the compressor station or surrounding area, or cause any fire. Any blowdown shall be made to an unconfined space.

(b) Each compressor station supplying hydrogen gas directly to a distribution system shall be provided with emergency shutdown facilities located outside the compressor station buildings, by means of which all hydrogen gas can be blocked out of the station. These shutdown facilities can be either automatic or manually operated, as local conditions designate.

**I-1.3.2.2 Engine Overspeed Stops.** Every compressor prime mover, except electrical induction or synchronous motors, shall be provided with an automatic device that is designed to shut down the unit before the maximum safe speed of either the prime mover or driven unit is exceeded.

### **I-1.3.3 Pressure Limiting Requirements in Compressor Stations**

**I-1.3.3.1 Capacity.** Pressure relief or other suitable protective devices of sufficient capacity and sensitivity shall be installed and maintained to ensure that the MAOP of the station piping and equipment is not exceeded by more than 10%.

**I-1.3.3.2 Installation.** A pressure relief valve or pressure limiting device, such as a pressure switch or unloading device, shall be installed in the discharge line of each positive displacement transmission compressor between the gas compressor and the first discharge block valve. If a pressure relief valve is the primary over-protection device, the relieving capacity shall be equal to or greater than the capacity of the compressor. If the relief valves on the compressor do not prevent the possibility of overpressuring the pipeline as specified in [para. PL-3.13](#), a pressure-relieving or pressure-limiting device shall be installed on the pipeline to prevent it from being overpressured beyond the limits required by this Code. Any pressure relief shall discharge to unconfined space and be remote from any hazards.

**I-1.3.3.3 Venting.** Vent lines provided to exhaust the hydrogen gas from the pressure relief valves to atmosphere shall be extended to a location where the hydrogen gas may be discharged without undue hazard. Vent lines shall have sufficient capacity so that they will not inhibit the performance of the relief valve. Any pressure relief shall apply to unconfined space and be remote from any hazards. See CGA G-5.5-2004.

**I-1.3.4 Cooling and Lubrication Failures.** All hydrogen gas compressor units shall be equipped with shutdown or alarm devices to activate in the event of inadequate cooling or lubrication of the units.

### **I-1.3.5 Explosion Prevention**

**I-1.3.5.1 Mufflers.** The external shell of mufflers for engines using hydrogen gas as fuel shall be designed in accordance with good engineering practice and shall be constructed of ductile materials. It is recommended that all compartments of the muffler be manufactured

with vent slots or holes in the baffles to prevent hydrogen gas from being trapped in the muffler.

**I-1.3.5.2 Building Ventilation.** Ventilation shall be ample to ensure that employees are not endangered under normal operating conditions (or such abnormal conditions as a blown gasket, packing gland, etc.) by accumulations of hazardous concentrations of flammable hydrogen gases in rooms, sumps, attics, pits, or similarly enclosed places, or in any portion thereof.

### **I-1.3.6 Hydrogen Gas Detection and Alarm Systems**

**I-1.3.6.1** Each compressor building in a compressor station where hazardous concentrations of hydrogen gas may accumulate shall have a fixed hydrogen gas detection and alarm system unless the building is constructed so that at least 50% of its upright side area is permanently open to the atmosphere or adequately ventilated by forced (Class 1, Division 1, as defined by NFPA 70, article 500) or natural ventilation.

**I-1.3.6.2** Except when shutdown of the system is necessary for maintenance, each hydrogen gas detection and alarm system required by this section shall

(a) continuously monitor the compressor building for a concentration of hydrogen gas in air of not more than 25% of the lower explosive limit

(b) warn persons about to enter the building and persons inside the building of the danger if that concentration of hydrogen gas is exceeded

**I-1.3.6.3** The compressor building configuration shall be considered in selecting the number, type, and placement of detectors and alarms.

**I-1.3.6.4** Alarm signals shall be unique and immediately recognizable, considering background noise and lighting, to personnel who are inside or immediately outside each compressor building.

## **I-1.4 Compressor Station Piping**

**I-1.4.1 Hydrogen Gas Piping.** The following are general provisions applicable to all hydrogen gas piping:

(a) *Specifications for Hydrogen Gas Piping.* All compressor station hydrogen gas piping, other than instrument, control, and sample piping, to and including connections to the main pipeline, shall be of steel and shall use a design factor,  $F$ , per [Table PL-3.7.1-1](#).

(b) *Installation of Hydrogen Gas Piping.* The provisions of [para. PL-3.7.4](#) shall apply, where appropriate, to hydrogen gas piping in compressor stations.

(c) *Testing of Hydrogen Gas Piping.* All hydrogen gas piping within a compressor station shall be tested after installation in accordance with the provisions of [para. PL-3.10.5](#) for pipelines and mains in Class 3 locations, except that small additions to operating stations need not be tested where operating conditions make it impractical to test.



(d) *Identification of Valves and Piping.* All emergency valves and controls shall be identified by signs. The function of all important hydrogen gas pressure piping shall be identified by signs or color codes.

**I-1.4.2 Fuel Gas Piping.** The following are specific provisions applicable to compressor station fuel hydrogen gas piping only:

(a) All fuel hydrogen gas lines within a compressor station that serve the various buildings and residential areas shall be provided with master shutoff valves located outside of any building or residential area.

(b) The pressure-regulating facilities for the fuel hydrogen gas system for a compressor station shall be provided with pressure-limiting devices to prevent the normal operating pressure of the system from being exceeded by more than 25%, or the MAOP by more than 10%.

(c) Suitable provision shall be made to prevent fuel hydrogen gas from entering the power cylinders of an engine and actuating moving parts while work is in progress on the engine or on equipment driven by the engine.

## I-2 DESIGN OF INSTRUMENT, CONTROL, AND SAMPLE PIPING

### I-2.1 Scope

**I-2.1.1** The requirements given in this section apply to the design of instrument, control, and sampling piping for safe and proper operation of the piping itself and do not cover design of piping to secure proper functioning of instruments for which the piping is installed.

**I-2.1.2** This section does not apply to permanently closed piping systems, such as fluid-filled, temperature responsive devices.

### I-2.2 Materials and Design

**I-2.2.1** The materials employed for valves, fittings, tubing, and piping shall be designed to meet the particular conditions of service.

**I-2.2.2** Takeoff connections and attaching bosses, fittings, or adapters shall be made of suitable material and shall be capable of withstanding the maximum service pressure and temperature of the piping or equipment to which they are attached. They shall be designed to satisfactorily withstand all stresses without failure by fatigue.

**I-2.2.3** A shutoff valve shall be installed in each takeoff line as near as practicable to the point of takeoff. Blow-down valves shall be installed where necessary for the safe operation of piping, instruments, and equipment.

**I-2.2.4** Piping subject to clogging from solids or deposits shall be provided with suitable connections for cleaning.

**I-2.2.5** Pipe or tubing required under this section may be specified by the manufacturers of the instrument, control apparatus, or sampling device, provided that the safety of the pipe or tubing as installed is at least equal to that otherwise required under the Code.

**I-2.2.6** Piping that may contain liquids shall be protected by heating or other suitable means from damage due to freezing.

**I-2.2.7** Piping in which liquids may accumulate shall be provided with drains or drips.

**I-2.2.8** The arrangement of piping and supports shall be designed to provide not only for safety under operating stresses, but also to provide protection for the piping against detrimental sagging, external mechanical injury, abuse, and damage due to unusual service conditions other than those connected with pressure, temperature, and service vibration.

**I-2.2.9** Suitable precautions shall be taken to protect against corrosion (see [para. GR-5.3.1.2](#)).

**I-2.2.10** Joints between sections of tubing and/or pipe, or between tubing and/or pipe and valves or fittings, shall be made in a manner suitable for the pressure and temperature conditions, such as by means of flared, flareless, and compression type fittings, or equal, or they may be of the brazed, screwed, or socket-welded type. If screwed-end valves are to be used with flared, flareless, or compression type fittings, adapters are required. Slip type expansion joints shall not be used; expansion shall be compensated for by providing flexibility within the piping or tubing system itself.

**I-2.2.11** After instrument, control, and sample piping has been installed and filled with hydrogen, all joints shall be examined using a hydrogen gas detector. Any leaks detected shall be repaired before the system is accepted for operational service.

## I-3 MISCELLANEOUS PIPING ASSEMBLIES

### I-3.1 Design and Location of Metering and Pressure/Flow Control

**I-3.1.1** All piping and piping components, up to and including the outlet stop valve(s) of individual meter and pressure/flow control runs, shall meet or exceed the maximum design pressure of the inlet piping system. Threaded reducing bushings should not be used in pressure/flow control facilities where they are subject to high-frequency piping vibrations. The design requirements of [para. PL-3.3](#) and [Table PL-3.7.1-1](#) apply to the design requirements of this section.

**I-3.1.2** All piping shall be tested in accordance with para. PL-3.10 and the Location Class requirements of Table PL-3.7.1-1. Instrumentation devices such as transmitters, recorders, controllers, etc., excluding testing instrumentation, should be isolated from the piping during the test. Test fluids shall be removed from piping and piping components, and the piping purged. Purge gas for cold gaseous hydrogen (GH<sub>2</sub>) lines shall be gaseous helium (GHe).

**I-3.1.3** Safety setbacks from sources of ignition or other potential hazards may be required.

### I-3.2 Metering Facilities

Particular consideration and attention shall be given to sizing meter run blowdowns and/or flow restricting plates for turbine and positive displacement meters. Rapid depressurization of meter runs can damage or destroy meters due to meter overspin and high differentials and can endanger personnel.

### I-3.3 Other (Nonmandatory) Considerations for Metering Facilities

**I-3.3.1** Meter proving reduces measurement uncertainty. Where meter design, size, and flow rate allow, consider installing meter proving taps.

**I-3.3.2** Upstream dry hydrogen gas filter(s) should be considered when installing rotary or turbine meters. Particulates and pipeline dust can contaminate meter lubricating oil and damage bearings and other internal meter components.

### I-3.4 Pressure/Flow Control Facilities

**I-3.4.1** Overpressure protection shall be provided by the use of

- (a) a monitor regulator in series with a controlling regulator (each regulator run)
- (b) adequately sized relief valve(s) downstream of the controlling regulator(s)
- (c) overpressure shutoff valve(s) upstream or downstream of the controlling regulator(s)

Installation of alarm devices that indicate primary (controlling) regulator failure are useful and should be considered for monitor regulator systems.

**I-3.4.2** Each regulator supply, control, and sensing line shall have a separate isolation valve for isolation purposes during regulator setup and maintenance, and to prevent a safety device (i.e., monitor, regulator) from becoming unintentionally inoperable due to plugging or freezing of instrument lines.

**I-3.4.3** Steps shall be taken to prevent the freezing-up (internal and external) of regulators, control valves, instrumentation, pilot controls, and valve actuation equip-

ment caused by moisture saturated instrument air or hydrogen gas, or external ambient conditions.

**I-3.4.4** Sound pressure levels of 110 dbA and greater shall be avoided to prevent damage to control equipment and piping.

**I-3.4.5** Hydrogen gas velocities in piping should not exceed the erosional velocity at peak conditions. Lower velocities are recommended. The erosional velocity,  $u_e$ , is calculated by:<sup>1</sup>

$$u_e = \frac{100}{\sqrt{\frac{29GP}{ZRT}}}$$

where

$G$  = gas gravity (0.0695)

$P$  = minimum pipeline pressure, psia

$R$  = universal gas constant

= 10.73 ft<sup>3</sup> · psia/(lb·mol · °R)

$T$  = flowing gas temperature, °R

$u_e$  = erosional velocity, ft/sec

$Z$  = compressibility factor at specified temperature and pressure, dimensionless

High hydrogen gas velocities in piping increase turbulence and pressure drop, contribute to excessive sound pressure levels (aerodynamic noise), and can cause internal piping erosion. Acoustically induced vibration in the piping shall be avoided at all times.

### I-3.5 Other (Nonmandatory) Considerations for Pressure/Flow Control Facilities

Installation of conical reducers immediately downstream of a regulator or control valve will allow a more gradual expansion of hydrogen gas to larger piping, and reduce turbulence and pressure drop during hydrogen gas expansion.

### I-3.6 Electrical Facilities and Electronic Equipment for Pressure/Flow Control and Metering Facilities

**I-3.6.1** All electrical equipment and wiring installed in pressure/flow control facilities and metering facilities shall conform to the requirements of NFPA 70 or other applicable electrical codes. Additional API and AGA references are listed in [Mandatory Appendix II](#).

**I-3.6.2** Electronic control, monitoring, and hydrogen gas measurement equipment shall be properly grounded and isolated from piping to help prevent overpressure/accidental shutoff situations caused by equipment failure due to lightning strikes and electrical transients and to

<sup>1</sup> Mohitpour, M., Golshan, H., and Murray, A. (2007). "Natural Gas Transmission." Pipeline Design & Construction: A Practical Approach (3rd ed., pp. 57–129). ASME Press.

prevent safety hazards caused by fault currents. Electrical isolation equipment for corrosion control purposes should not be installed in buildings unless specifically designed to be used in combustible atmospheres.

**I-3.6.3** Uninterruptible power sources or redundant backup systems shall be considered to help prevent over-pressure/unintentional shutoff situations caused by power outages.

**I-3.6.4** A useful reference for electronic hydrogen gas measurements is API Manual of Petroleum Measurement Standards, Chapter 21, Section 1 — Electronic Gas Measurement.

## MANDATORY APPENDIX II REFERENCE STANDARDS

(23)

This Appendix provides a listing of standards incorporated in this Code by reference, and the names and websites of the sponsoring organizations. It is not practical to refer to a specific edition of each standard throughout the Code text; instead, the reference dates for the specific editions are shown here. For ASME codes and standards, specific edition reference dates are not provided; rather, the latest published edition in effect at the time this Code is specified is the specific edition referenced by this Code. Subsequent issues and revisions of these referenced standards will be listed (after review and acceptance by the Code Committee) in revisions of this Appendix. All identical specifications are indicated by the ASME/originating organization symbols.

| <b>API Recommended Practice</b> | <b>ASME Boiler and Pressure Vessel Code</b> | <b>ASME Standards (Cont'd)</b> |
|---------------------------------|---|--------------------------------|
| RP 941-2016                     | Section II, Part A                          | B31.1                          |
| RP 1102                         | Section II, Part B                          | B31.2                          |
|                                 | Section II, Part C                          | B31.3                          |
|                                 | Section II, Part D                          | B31.4                          |
| <b>API Specifications</b>       | Section V                                   | B31.8                          |
| 5B-2012                         | Section VIII, Division 1                    | B31.8S                         |
| 5L-2007                         | Section VIII, Division 2                    | B31E                           |
| 5L-2012                         | Section VIII, Division 3                    | B36.10M                        |
| 6D-2014                         | Section IX                                  | B36.19M                        |
| 609-2016                        |   | B46.1                          |
| <b>API Standards</b>            | <b>ASME Standards</b>                       | API 579-1/ASME FFS-1           |
| 521                             | B1.1  | PCC-1                          |
| 526-2009                        | B1.20.1                                     | PTC 19.3 TW                    |
| 579-2001                        | B1.20.3                                     | QSP-1                          |
| 594-2010                        | B1.20.7                                     | STP/PT-003                     |
| 598                             | B16.1                                       | STP/PT-006                     |
| 599-2013                        | B16.5                                       |                                |
| 600-2015                        | B16.9                                       | <b>ASNT Standards</b>          |
| 602-2015                        | B16.10                                      | ANSI/ASNT CP-189               |
| 603-2013                        | B16.11                                      | SNT TC-1A-2016                 |
| 608-2012                        | B16.14                                      |                                |
| 609                             | B16.15                                      | <b>ASTM Specifications</b>     |
| 941                             | B16.20                                      | A20/A20M-2015                  |
| 1104-2013                       | B16.21                                      | A36/A36M-2014                  |
|                                 | B16.24                                      | A53/A53M-2012                  |
| <b>ASA Standard</b>             | B16.25                                      | A53 A & B                      |
| B31.3-1966                      | B16.34                                      | A105/A105M-2014                |
|                                 | B16.36                                      | A106/A106M-2015                |
| <b>ASQ Standards</b>            | B16.38                                      | A134-1996 (R2012)              |
| 9000-2015                       | B16.47                                      | A135/A135M-2009 (R2014)        |
| 9001-2015                       | B16.48                                      | A139/A139M-2016                |
| 9004-2018                       | B16.50                                      | A179/A179M (R2012)             |
|                                 | B18.2.1                                     | A181/A181M-2014                |
| <b>ASCE Standard</b>            | B18.2.2                                     | A182/A182M-2016                |
| ASCE 7-10 (2010)                | B31G  | A193/A193M-2016                |
|                                 | B31T  | A194/A194M-2016                |

**ASTM Specifications (Cont'd)**

A202  
A203  
A204/A204M-2012  
A210/A210M-2002 (R2012)  
A213/A213M-2015  
A216/A216M-2016  
A217/A217M-2014  
A234/A234M-2015  
A240/A240M-2016  
A249/A249M-2016  
A263-2012  
A264-2012  
A265-2012  
A269/A269M-2015  
A276/A276M-2016  
A283/A283M-2013  
A285/A285M-2012  
A299/A299M-2009 (R2014)  
  
A302/A302M-2012  
A307-2014  
A312/A312M-2016  
A320/A320M-2015  
A333/A333M-2016  
A334/A334M-2004 (R2016)  
A335/A335M-2015  
A350/A350M-2015  
A351/A351M-2016  
A352/A352M-2008 (R2012)  
A354/A354M-2011  
A358/A358M-2015  
A369/A369M-2011  
A370-2016  
A376/A376M-2014  
A381-1996 (R2012)  
A387/A387M-2011  
  
A403/A403M-2016  
A409/A409M-2015  
A420/A420M-2016  
A426/A426M-2013  
A437/A437M-2015  
A449  
A451/A451M-2014  
A453/A453M-2016  
A479/A479M-2016  
  
A516/A516M-2010 (R2015)  
A524-1996 (R2012)  
A537/A537M-2013  
A563-2015

**ASTM Specifications (Cont'd)**

A587-1996 (R2012)  
  
A671/A671M-2016  
A672/A672M-2014  
A675/A675M-2014  
A691/A691M (R2014)  
A833  
A1011/A1011M-2015  
  
B21/B21M-2014  
B26/B26M-2014  
B42/B42M-2015  
B43-2015  
B61-2015  
B62-2015  
B68/B68M-2011  
B75/B75M-2011  
B88-2014  
B96/B96M-2016  
B98/B98M-2013  
B127-2005 (R2014)  
B148-2014  
B150/B150M-2012  
B152/B152M-2013  
B164-2003 (R2014)  
B165-2005 (R2014)  
B169/B169M-2015  
B171/B171M-2012  
B187/B187M-2016  
  
B209-2014  
B210-2012  
B211-2012  
B221-2014  
B241/B241M-2016  
B247-2015  
B280-2016  
B283/B283M-2016  
  
B345/B345M-2011  
B361-2016  
B366/B366M-2016  
B466/B466M-2014  
B467-2014  
B491/B491M-2015  
B547/B547M-2010  
B564-2015  
B584-2014  
B648-2015  
B725-2005 (R2015)

**ASTM Specifications (Cont'd)**

E18-2016  
E92-2016  
E94-2004  
E110  
E114-1995  
E114-2015  
E125-1963 (R2013)  
E142-1992  
E155-2015  
E164  
E165/E165M-2009 (R2012)  
E186-1998  
E186-2015  
E213-2014  
E213-2020  
E272-2015  
E280-2015  
E310-2015  
E390  
E446-1998  
E446-2015  
E709-1980  
E709-2015  
E1212  
E1648  
  
F3125-2015

**AWS Standards**

A3.0-2010  
A4.3  
A5.1-2012  
A5.4-2012  
A5.9-2012  
A5.11-2010  
A5.14-2011  
A5.21-2011  
A5.22-2012  
B4.0  
C3.3

**CDA Publication**

Copper Tube Handbook, 1995

**CGA Publications**

G-5.5-2004  
G-5.5-2014  
G-5.6

**CSA/AM Publication**

HGV 4.10-2015

|                                       |  |                            |
|---------------------------------------|--|----------------------------|
| <b>Canadian Standards Association</b> | SP-58-2009                             | SP 0472-2015               |
| DOT-T-05-01                           | <b>MSS Standard Practices (Cont'd)</b> | <b>NASA</b>                |
| Z245.1-2014                           | SP-65-2012                             | NSS 1740.16                |
|                                       | SP-75-2014                             |                            |
| <b>EJMA Publications</b>              | SP-79-2011                             | <b>NFPA Specifications</b> |
| EJMA Standards, 10th Ed., 2015        | SP-80-2013                             | ANSI/NFPA 54               |
| GRI Report No. 91/0284 GPTC Guide     | SP-83-2014                             | NFPA 10-2014               |
|                                       | SP-97-2012                             | NFPA 30-2015               |
| <b>MSS Standard Practices</b>         | SP-105-2010                            | NFPA 70-2015               |
| SP-42-2013                            | SP-119-2010                            | NFPA 99                    |
| SP-43-2013                            | <b>NACE Publications</b>               | <b>PFI Standards</b>       |
| SP-44-2010                            | 37519-1985, Corrosion Data Survey —    | ES-01                      |
| SP-51-2012                            | Metals Section, sixth ed.              | ES-7-2013                  |
| SP-53-2012                            | MR 0175-2015                           | ES-21                      |
| SP-55-2011                            | SP 0170-2012                           |                            |

GENERAL NOTE: The issue date shown immediately following the hyphen after the number of the standard (e.g., A53/A53M-2012) is the effective date of the issue (edition) of the standard. Any additional number shown following the issue date and prefixed by the letter “R” is the latest date of reaffirmation [e.g., B725-2005 (R2015)].

Specifications and standards of the following organizations appear in this Appendix:

|      |  |  |
|------|--|--|
| AISC | American Institute of Steel Construction                                       | <a href="http://www.aisc.org">www.aisc.org</a>                   |
| API  | American Petroleum Institute   | <a href="http://www.api.org">www.api.org</a>                     |
| ASCE | American Society of Civil Engineers  | <a href="http://www.asce.org">www.asce.org</a>                   |
| ASME | The American Society of Mechanical Engineers                                   | <a href="http://www.asme.org">www.asme.org</a>                   |
| ASNT | American Society for Nondestructive Testing                                    | <a href="http://www.asnt.org">www.asnt.org</a>                   |
| ASQ  | American Society for Quality   | <a href="http://www.asq.org">www.asq.org</a>                     |
| ASTM | ASTM International   | <a href="http://www.astm.org">www.astm.org</a>                   |
| AWS  | American Welding Society   | <a href="http://www.aws.org">www.aws.org</a>                     |
| CDA  | Copper Development Association, Inc.   | <a href="http://www.copper.org">www.copper.org</a>               |
| CGA  | Compressed Gas Association, Inc.   | <a href="http://www.cganet.com">www.cganet.com</a>               |
| CSA  | Canadian Standards Association   | <a href="http://www.csagroup.org">www.csagroup.org</a>           |
| EJMA | Expansion Joint Manufacturers Association, Inc.                                | <a href="http://www.ejma.org">www.ejma.org</a>                   |
| GTI  | Gas Technology Institute   | <a href="http://www.gastechnology.org">www.gastechnology.org</a> |
| MSS  | Manufacturers Standardization Society of the Valve and Fittings Industry, Inc. | <a href="http://www.msshq.org">www.msshq.org</a>                 |
| NACE | NACE International   | <a href="http://www.nace.org">www.nace.org</a>                   |
| NFPA | National Fire Protection Association   | <a href="http://www.nfpa.org">www.nfpa.org</a>                   |
| PFI  | Pipe Fabrication Institute   | <a href="http://www.pfi-institute.org">www.pfi-institute.org</a> |

GENERAL NOTE: Some of the organizations listed above publish standards that have been approved as American National Standards. Copies of these standards may also be obtained from American National Standards Institute (ANSI), [www.ansi.org](http://www.ansi.org).



## MANDATORY APPENDIX III SAFEGUARDING

### III-1 SCOPE

Safeguarding is the provision of protective measures to minimize the risk of accidental damage to the piping or to minimize the harmful consequences of possible piping failure.

In most instances, the safeguarding inherent in the facility (the piping, the plant layout, and its operating practices) is sufficient without need for additional safeguarding. In some instances, however, engineered safeguards must be provided.

This Appendix outlines some considerations pertaining to the selection and use of safeguarding. Where safeguarding is required by the Code, it is necessary to consider only the safeguarding that will be suitable and effective for the purposes and functions stated in the Code or evident from the designer's analysis of the application.

### III-2 GENERAL CONSIDERATIONS

In evaluating a piping installation design to determine what safeguarding may exist or is necessary, the following should be reviewed:

(a) the hazardous properties of hydrogen, considered under the most severe combination of temperature, pressure, and composition in the range of expected operating conditions.

(b) the quantity of hydrogen that could be released by piping failure, considered in relation to the environment, recognizing the possible hazards ranging from large releases to small leakages.

(c) expected conditions in the environment, evaluated for their possible effect on the hazards caused by a possible piping failure. This includes consideration of ambient or surface temperature extremes, degree of ventilation, proximity of fired equipment, etc.

(d) the probable extent of operating, maintenance, and other personnel exposure, as well as reasonably probable sources of damage to the piping from direct or indirect causes.

(e) the probable need for grounding, bonding, or specialized electrostatic discharge techniques to minimize ignition of released hydrogen due to accumulation of static charges.

(f) the safety inherent in the piping by virtue of materials of construction, methods of joining, and history of service reliability.

### III-3 SAFEGUARDING BY PLANT LAYOUT AND OPERATION

Representative features of plant layout and operation that may be evaluated and selectively used as safeguarding include

(a) plant layout features, such as open-air process equipment structures, spacing and isolation of hazardous areas, buffer areas between plant operations and populated communities, or control over plant access

(b) protective installations, such as fire protection systems, barricades or shields, ventilation to remove released hydrogen, and instruments for remote monitoring and control

(c) operating practices, such as restricted access to processing areas; work permit system for hazardous work; or special training for operating, maintenance, and emergency crews

(d) means for safe discharge of hydrogen released during pressure-relief device operation, blowdown, cleanout, etc.

(e) procedures for startup, shutdown, and management of operating conditions, such as gradual pressurization or depressurization, and gradual warmup or cooldown, to minimize the possibility of piping failure

### III-4 ENGINEERED SAFEGUARDS

Engineered safeguards that may be evaluated and selectively applied to provide added safeguarding include

(a) means to protect piping against possible failures, such as

(1) thermal insulation, shields, or process controls to protect from excessively high or low temperature and thermal shock

(2) armor, guards, barricades, or other protection from mechanical abuse

(3) damping or stabilization of process or fluid flow dynamics to eliminate or to minimize or protect against destructive loads (e.g., severe vibration pulsations, cyclic operating conditions)

*(b)* means to protect people and property against harmful consequences of possible piping failure, such as confining and safely disposing of escaped hydrogen by shields for flanged joints, valve bonnets, or gages

*(c)* limiting the quantity or rate of hydrogen escaping by automatic shutoff or excess flow valves, additional block valves, flow-limiting orifices, or automatic shut-down of pressure source

*(d)* limiting the quantity of hydrogen in process at any time, where feasible

## MANDATORY APPENDIX IV NOMENCLATURE

| Symbol   | Definition  | Units [Note (1)] |                    |
|----------|---|------------------|--------------------|
|          |   | SI               | U.S. Customary     |
| $A$      | Factor for determining minimum value of $R_1$   | ...              | ...                |
| $A_1$    | Area required for branch reinforcement  | mm <sup>2</sup>  | in. <sup>2</sup>   |
| $A_2$    | Area available for branch reinforcement in run pipe   | mm <sup>2</sup>  | in. <sup>2</sup>   |
| $A_3$    | Area available for branch reinforcement in branch pipe                                      | mm <sup>2</sup>  | in. <sup>2</sup>   |
| $A_4$    | Area available for branch reinforcement in pad or connection                                | mm <sup>2</sup>  | in. <sup>2</sup>   |
| $A_p$    | Cross-sectional area of pipe  | mm <sup>2</sup>  | in. <sup>2</sup>   |
| $A_{sf}$ | Conveyed fluid cross-sectional area considering nominal pipe thickness less allowances      | mm <sup>2</sup>  | in. <sup>2</sup>   |
| $A_{sp}$ | Pipe cross-sectional area considering nominal pipe thickness less allowances                | mm <sup>2</sup>  | in. <sup>2</sup>   |
| $C$      | Cold spring factor  | ...              | ...                |
| $C$      | Material constant used in computing Larson–Miller parameter                                 | ...              | ...                |
| $C_1$    | Estimated self-spring or relaxation factor  | ...              | ...                |
| $C_x$    | Size of fillet weld, socket welds other than flanges  | mm               | in.                |
| $c$      | Sum of mechanical allowances (thread or groove depth) plus corrosion and erosion allowances | mm               | in.                |
| $c_I$    | Sum of internal allowances  | mm               | in.                |
| $c_o$    | Sum of external allowances  | mm               | in.                |
| $D$      | Outside diameter of pipe as listed in tables of standards and specifications or as measured | mm               | in.                |
| $D_b$    | Outside diameter of branch pipe   | mm               | in.                |
| $D_h$    | Outside diameter of header pipe   | mm               | in.                |
| $d$      | Inside diameter of pipe   | mm               | in.                |
| $d_1$    | Effective length removed from pipe at branch  | mm               | in.                |
| $d_2$    | Half-width of reinforcement zone  | mm               | in.                |
| $d_b$    | Inside diameter of branch pipe  | mm               | in.                |
| $d_g$    | Inside or pitch diameter of gasket  | mm               | in.                |
| $d_h$    | Inside diameter of header pipe  | mm               | in.                |
| $d_x$    | Design inside diameter of extruded outlet   | mm               | in.                |
| $E$      | Quality factor  | ...              | ...                |
| $E$      | Modulus of elasticity (at specified condition)  | MPa              | ksi                |
| $E_a$    | Reference modulus of elasticity at 21°C (70°F)  | MPa              | ksi                |
| $E_c$    | Casting quality factor  | ...              | ...                |
| $E_j$    | Joint quality factor  | ...              | ...                |
| $E_m$    | Modulus of elasticity at maximum or minimum temperature                                     | MPa              | ksi                |
| $E_m$    | Modulus of elasticity at the temperature of the condition                                   | MPa              | ksi                |
| $E_t$    | Modulus of elasticity at test temperature   | MPa              | ksi                |
| $F_a$    | Axial force   | N                | lbf × 1,000 (kips) |

| Symbol    | Definition  | Units [Note (1)] |                |
|-----------|---|------------------|----------------|
|           |   | SI               | U.S. Customary |
| $F_{sa}$  | Sustained axial force including the effects of weight, other sustained loads, and internal pressure   | N                | lb             |
| $f$       | Stress range factor   | ...              | ...            |
| $f$       | Stress range reduction factor   | ...              | ...            |
| $f_m$     | Maximum value of stress range factor  | ...              | ...            |
| $g$       | Root gap for welding  | mm               | in.            |
| $h$       | Flexibility characteristic  | ...              | ...            |
| $h_f$     | Material performance factor from <a href="#">Mandatory Appendix IX, Table IX-5A</a> . Material performance factors account for the adverse effects of hydrogen gas on the mechanical properties of carbon steels used in the construction of pipelines. | ...              | ...            |
| $h_x$     | Height of extruded outlet   | mm               | in.            |
| $i$       | Stress intensification factor   | ...              | ...            |
| $i_a$     | Axial force stress intensification factor   | ...              | ...            |
| $i_i$     | In-plane stress intensification factor  | ...              | ...            |
| $i_o$     | Out-plane stress intensification factor   | ...              | ...            |
| $i_{s,i}$ | In-plane sustained stress index   | ...              | ...            |
| $i_{s,o}$ | Out-plane sustained stress index  | ...              | ...            |
| $K$       | Factor determined by ratio of branch diameter to run diameter   | ...              | ...            |
| $K_1$     | Constant in empirical flexibility equation  | ...              | ...            |
| $K_s$     | Factor for statistical variation in test results (see <a href="#">para. IP-3.8.4</a> )  | ...              | ...            |
| $k$       | Flexibility factor  | ...              | ...            |
| $L$       | Developed length of piping between anchors  | m                | ft             |
| $L_4$     | Height of reinforcement zone outside run pipe   | mm               | in.            |
| $L_5$     | Height of reinforcement zone for extruded outlet  | mm               | in.            |
| $LMP$     | Larson–Miller parameter, used to estimate design life   | ...              | ...            |
| $M$       | Length of full thickness pipe adjacent to miter bend  | mm               | in.            |
| $M_f$     | Material performance factor that addresses loss of material properties associated with hydrogen gas service. See <a href="#">Mandatory Appendix IX</a> for performance factor tables and application.   | ...              | ...            |
| $M_i$     | In-plane bending moment   | N-mm             | in.-lbf        |
| $M_o$     | Out-plane bending moment  | N-mm             | in.-lbf        |
| $M_{s,i}$ | In-plane bending moment for the sustained condition being evaluated   | N-mm             | in.-lbf        |
| $M_{s,o}$ | Out-plane bending moment for the sustained condition being evaluated  | N-mm             | in.-lbf        |
| $M_{st}$  | Sustained torsional moment  | N-mm             | in.-lbf        |
| $M_t$     | Torsional moment  | N-mm             | in.-lbf        |
| $m$       | Misfit of branch pipe   | mm               | in.            |
| $N$       | Equivalent number of full displacement cycles   | ...              | ...            |
| $N$       | Equivalent number of full operating cycles  | ...              | ...            |
| $N_E$     | Number of cycles of maximum computed displacement stress range  | ...              | ...            |
| $N_E$     | Number of cycles of maximum computed operating stress range   | ...              | ...            |
| $N_i$     | Number of cycles associated with displacement stress range, $S_i$ ( $i = 1, 2, \dots$ )   | ...              | ...            |
| $N_i$     | Number of cycles associated with operating stress range, $S_i$ ( $i = 1, 2, \dots$ )  | ...              | ...            |
| $N_t$     | Number of fatigue tests performed to develop the material factor, $X_m$   | ...              | ...            |
| $P$       | Design gage pressure  | kPa              | psi            |

| Symbol    | Definition  | Units [Note (1)] |                |
|-----------|---|------------------|----------------|
|           |   | SI               | U.S. Customary |
| $P_{a2}$  | See ASME BPVC, Section VIII, Division 1, UG-28  | ...              | ...            |
| $P_i$     | Gage pressure during service condition $i$  | kPa              | psi            |
| $P_j$     | Piping maximum internal pressure for load case $j = 1$ ; multiple cases subscripted, 2, 3, ...                            | kPa              | psi            |
| $P_m$     | Maximum allowable internal pressure for miter bends   | kPa              | psi            |
| $P_{max}$ | Maximum allowable gage pressure for continuous operation of component at maximum design temperature                       | kPa              | psi            |
| $P_S$     | Limiting design pressure based on column instability, for convoluted U-shaped bellows                                     | kPa              | psi            |
| $P_T$     | Minimum test gage pressure  | kPa              | psi            |
| $R$       | Range of reaction forces or moments in flexibility analysis   | N or N-mm        | lbf or in.-lbf |
| $R_1$     | Effective radius of miter bend  | mm               | in.            |
| $R_1$     | Bend radius of welding elbow or pipe bend   | mm               | in.            |
| $R_a$     | Estimated instantaneous reaction force or moment at installation temperature  | N or N-mm        | lbf or in.-lbf |
| $R_m$     | Estimated instantaneous maximum reaction force or moment at maximum or minimum metal temperature                          | N or N-mm        | lbf or in.-lbf |
| $R_{min}$ | Minimum ratio of stress ranges (see para. IP-3.8.4 for further details)   | ...              | ...            |
| $R_T$     | Ratio of the average temperature-dependent trend curve value of tensile strength to the room temperature tensile strength | ...              | ...            |
| $R_Y$     | Ratio of the average temperature-dependent trend curve value of yield strength to the room temperature yield strength     | ...              | ...            |
| $r_2$     | Mean radius of pipe using nominal wall thickness, $\bar{T}$   | mm               | in.            |
| $r_i$     | Ratio of lesser computed displacement stress range, $S_i$ , to maximum computed stress range, $S_E$ ( $i = 1, 2, \dots$ ) | ...              | ...            |
| $r_i$     | Ratio of lesser computed operating stress range, $S_i$ , to maximum computed stress range, $S_E$ ( $i = 1, 2, \dots$ )    | ...              | ...            |
| $r_x$     | External contour radius of extruded outlet  | mm               | in.            |
| $S$       | Basic allowable stress for metals   | MPa              | ksi            |
| $S$       | Bolt design stress  | MPa              | ksi            |
| $S$       | Allowable stress for metals   | MPa              | ksi            |
| $S$       | Stress intensity  | MPa              | ksi            |
| $S_A$     | Allowable stress range for displacement stress  | MPa              | ksi            |
| $S_a$     | Bolt design stress at atmospheric temperature   | MPa              | ksi            |
| $S_a$     | Stress due to axial force   | MPa              | ksi            |
| $S_b$     | Bolt design stress at design temperature  | MPa              | ksi            |
| $S_b$     | Resultant bending stress  | MPa              | ksi            |
| $S_c$     | Basic allowable stress at minimum metal temperature expected during the displacement cycle under analysis                 | MPa              | ksi            |
| $S_d$     | Allowable stress from <a href="#">Mandatory Appendix IX, Table IX-1A</a> for the material at design temperature           | MPa              | ksi            |
| $S_E$     | Computed displacement stress range  | MPa              | ksi            |
| $S_E$     | Maximum operating stress range  | MPa              | ksi            |
| $S_f$     | Allowable stress for flange material or pipe  | MPa              | ksi            |
| $S_H$     | Mean long-term hydrostatic strength (LTHS)  | kPa              | psi            |
| $S_h$     | Basic allowable stress at maximum metal temperature expected during the displacement cycle under analysis                 | MPa              | ksi            |
| $S_i$     | A computed displacement stress range smaller than $S_E$ ( $i = 1, 2, \dots$ )   | MPa              | ksi            |
| $S_i$     | A computed operating stress range smaller than $S_E$ ( $i = 1, 2, \dots$ )  | MPa              | ksi            |

| Symbol      | Definition  | Units [Note (1)] |                |
|-------------|---|------------------|----------------|
|             |   | SI               | U.S. Customary |
| $S_i$       | Equivalent stress during service condition, $i$ (the higher of $S_{pi}$ and $S_L$ )   | MPa              | ksi            |
| $S_L$       | Sum of longitudinal stresses  | MPa              | ksi            |
| $S_o$       | Operating stress  | MPa              | ksi            |
| $S_{oA}$    | Allowable operating stress limit  | MPa              | ksi            |
| $S_{om}$    | Greatest of maximum operating stress and maximum operating stress range   | MPa              | ksi            |
| $S_{pi}$    | Equivalent stress for pressure during service condition, $i$  | MPa              | ksi            |
| $S_S$       | Mean short-term burst stress  | kPa              | psi            |
| $S_{sa}$    | Stress due to the sustained axial force summation   | kPa              | psi            |
| $S_{sb}$    | Stress due to the indexed sustained bending moments' vector summation   | kPa              | psi            |
| $S_{st}$    | Stress due to the sustained torsional moment  | kPa              | psi            |
| $S_T$       | Specified minimum tensile strength at room temperature  | MPa              | ksi            |
| $S_T$       | Allowable stress at test temperature  | MPa              | ksi            |
| $S_t$       | Torsional stress  | MPa              | ksi            |
| $S_t$       | Total stress range for design fatigue curves applying to austenitic stainless steel expansion joints  | ...              | psi            |
| $S_Y$       | Specified minimum yield strength at room temperature  | MPa              | ksi            |
| $S_Y$       | Yield strength (ASME BPVC)  | MPa              | ksi            |
| $S_{yt}$    | Yield strength at temperature   | MPa              | ksi            |
| $s$         | Miter spacing at pipe centerline  | mm               | in.            |
| $T$         | Pipe wall thickness (measured or minimum per purchase specification)  | mm               | in.            |
| $T_2$       | Minimum thickness of fabricated lap   | mm               | in.            |
| $T_b$       | Branch pipe wall thickness (measured or minimum per purchase specification)   | mm               | in.            |
| $T_c$       | Crotch thickness of branch connections  | mm               | in.            |
| $T_E$       | Design temperature during service condition, $i$ (temperature corresponding to $S_i$ , <a href="#">Mandatory Appendix IX, Table IX-1A</a> ) | °C               | °F             |
| $T_h$       | Header pipe wall thickness (measured or minimum per purchase specification)   | mm               | in.            |
| $T_i$       | Actual temperature during service condition, $i$  | °C               | °F             |
| $T_j$       | Pipe maximum or minimum metal temperature for load case $j = 1$ ; multiple cases subscripted, 2, 3, ...                                     | °C               | °F             |
| $T_r$       | Minimum thickness of reinforcing ring or saddle made from pipe (nominal thickness if made from plate)                                       | mm               | in.            |
| $T_s$       | Effective branch wall thickness   | mm               | in.            |
| $T_x$       | Corroded finished thickness of extruded outlet  | mm               | in.            |
| $\bar{T}$   | Nominal wall thickness of pipe  | mm               | in.            |
| $\bar{T}_b$ | Nominal branch pipe wall thickness  | mm               | in.            |
| $\bar{T}_h$ | Nominal header pipe wall thickness  | mm               | in.            |
| $\bar{T}_r$ | Nominal thickness of reinforcing ring or saddle   | mm               | in.            |
| $\bar{T}_w$ | Nominal wall thickness, thinner of components joined by butt weld   | mm               | in.            |
| $t$         | Pressure design thickness   | mm               | in.            |
| $t_b$       | Pressure design thickness of branch   | mm               | in.            |
| $t_c$       | Throat thickness of cover fillet weld   | mm               | in.            |
| $t_h$       | Pressure design thickness of header   | mm               | in.            |
| $t_i$       | Total duration of service condition, $i$ , at pressure, $P_i$ , and temperature, $T_i$  | h                | hr             |

| Symbol       | Definition  | Units [Note (1)] |                  |
|--------------|---|------------------|------------------|
|              |   | SI               | U.S. Customary   |
| $t_m$        | Minimum required thickness, including mechanical, corrosion, and erosion allowances   | mm               | in.              |
| $t_{\min}$   | For branch, the smaller of $\bar{T}_b$ or $\bar{T}_r$   | mm               | in.              |
| $t_{ri}$     | Rupture life of a component subjected to repeated service conditions, $i$ , and stress, $S_i$                                 | h                | hr               |
| $U$          | Straight line distance between anchors  | m                | ft               |
| $u$          | Creep-rupture usage factor, summed up from individual usage factors, $t_i/t_{ri}$   | ...              | ...              |
| $X$          | Factor for modifying the allowable stress range, $S_b$ , for bellows expansion joint (see para. IP-3.8.4 for further details) | ...              | ...              |
| $X_1$        | Ring reinforcement area   | mm <sup>2</sup>  | in. <sup>2</sup> |
| $X_2$        | Fillet weld reinforcement area  | mm <sup>2</sup>  | in. <sup>2</sup> |
| $x_{\min}$   | Size of fillet weld to slip-on or socket welding flange   | mm               | in.              |
| $Y$          | Coefficient for effective stressed diameter   | ...              | ...              |
| $Y+$         | Single acting support — a pipe support that provides support to the piping system in only the vertically upward direction     | ...              | ...              |
| $y$          | Resultant of total displacement   | mm               | in.              |
| $Z$          | Section modulus of pipe   | mm <sup>3</sup>  | in. <sup>3</sup> |
| $Z_e$        | Effective section modulus for branch  | mm <sup>3</sup>  | in. <sup>3</sup> |
| $\alpha$     | Angle of change in direction at miter joint   | deg              | deg              |
| $\beta$      | Smaller angle between axes of branch and run  | deg              | deg              |
| $\Delta T_e$ | Range of temperature change for full cycle  | °C               | °F               |
| $\Delta T_n$ | Range of temperature change for lesser cycle ( $n = 1, 2, \dots$ )  | °C               | °F               |
| $\phi$       | Angle of miter cut  | deg              | deg              |

GENERAL NOTE: For Code reference to this Appendix, see para. GR-1.7.

NOTE: (1) Note that the use of these units is not required by the Code. They represent sets of consistent units (except where otherwise stated) that may be used in computations. Stress values given in ksi (MPa) may be multiplied by 1,000 for use in equations that involve pressure in psi (kPa).



# MANDATORY APPENDIX VII

## GAS LEAKAGE AND CONTROL CRITERIA

### VII-1 SCOPE

This Appendix provides criteria for detection, grading, and control of hydrogen gas leakage in pipelines and underground piping in process units.

### VII-2 DEFINITIONS

NOTE: These definitions are applicable to this Appendix only.

*bar hole*: a hole that is made in the soil or paving for the specific purpose of testing the subsurface atmosphere with a hydrogen detector.

*building*: any structure that is normally or occasionally entered by humans for business, residential, or other purposes, and in which hydrogen gas could accumulate.

*enclosed space*: any subsurface structure, such as vaults, catch basins, or manholes, of sufficient size to accommodate a person, and in which hydrogen gas could accumulate.

*follow-up inspection*: an inspection performed after a repair has been completed to determine the effectiveness of the repair.

*gas detector*: a device capable of detecting and measuring hydrogen gas concentrations in the atmosphere.

*hydrogen-associated substructure*: a device or facility utilized by a hydrogen gas company, such as a valve box, vault, test box, or vented casing pipe, that is not intended for storing, transmitting, or distributing hydrogen gas.

*LEL*: the lower explosive limit of the gas (hydrogen) being transported; this is reported to be approximately 18% by volume in air by NASA, NSS 1740.16.

*LFL*: the lower flammable limit of the gas (hydrogen) being transported; this is reported to be approximately 4% by volume in air by NASA, NSS 1740.16.

*ppm*: parts per million

*prompt action*: dispatching qualified personnel without delay for evaluating and, where necessary, abating the existing or probable hazard.

*reading*: a repeatable deviation on a gas detector, expressed in LEL. Where the reading is in an unvented enclosed space, consideration should be given to the

rate of dissipation when the space is ventilated and the rate of accumulation when the space is resealed.

*small substructures (other than hydrogen-associated substructures)*: any subsurface structures that are of insufficient size to accommodate a person, such as telephone and electrical ducts and conduit or non-hydrogen-associated valve and meter boxes, and in which hydrogen gas could accumulate or migrate.

*tunnel*: a subsurface passageway large enough for a person to enter and in which hydrogen gas could accumulate.

### VII-3 LEAKAGE SURVEY AND TEST METHODS

#### VII-3.1 Surveys and Methods

The following hydrogen gas leakage surveys and test methods may be employed, as applicable, singly or in combination, in accordance with written procedures:

- (a) surface hydrogen gas survey
- (b) subsurface gas detector survey (including bar hole surveys)
- (c) vegetation survey
- (d) pressure drop test
- (e) bubble leakage test
- (f) ultrasonic leakage test

Other survey and test methods may be employed if they are deemed appropriate and are conducted in accordance with procedures that have been tested and proven to be at least equal to the methods listed in this section.

#### VII-3.2 Surface Hydrogen Gas Detection Survey

**VIII-3.2.1 Definition.** This survey is a continuous sampling of the atmosphere at or near ground level for buried hydrogen gas facilities and adjacent to above-ground hydrogen gas facilities with a gas detector system capable of detecting a concentration of 50 ppm of hydrogen gas in air at any sampling point.

**VIII-3.2.2 Procedure.** Equipment used to perform these surveys may be portable or mobile. For buried piping, sampling of the atmosphere shall take place, where practical, at no more than 51 mm (2 in.) above the ground surface. In areas where the piping is under pavement, samplings shall also be at curb lines, available ground surface openings (such as manholes; catch basins; sewer, power, and telephone duct openings; fire and

traffic signal boxes; or cracks in the pavement or sidewalk), or other interfaces where the venting of hydrogen gas is likely to occur. Sampling shall be adjacent to exposed piping.

**VII-3.2.3 Utilization.** The use of this survey method may be limited by adverse conditions (such as excessive wind, excessive soil moisture, or surface sealing by ice or water). The survey shall be conducted at speeds slow enough to allow an adequate sample to be continuously obtained by placement of equipment intakes over the most logical venting locations, giving consideration to the location of hydrogen gas facilities and any adverse conditions that might exist.

### VII-3.3 Subsurface Hydrogen Gas Detection Survey

**VII-3.3.1 Definition.** This survey is a sampling of the subsurface atmosphere with a gas detector or other device capable of detecting 0.5% hydrogen gas in air at the sample point.

- (23) **VII-3.3.2 Procedure.** The survey shall be conducted by performing tests with a gas detector in a series of available openings (enclosed spaces and small substructures) and/or bar holes, over and/or adjacent to the hydrogen gas facility. The location of the hydrogen gas facility and its proximity to buildings and other structures shall be considered in the spacing of the sample points. Sampling points shall be as close as possible to the main or pipeline, and never further than 5 m (15 ft) laterally from the facility. Along the route of the main or pipeline, sampling points shall be placed at twice the distance between the pipeline and the nearest building wall, or at 9 m (30 ft), whichever is shorter, but in no case need the spacing be less than 3 m (10 ft). The sampling pattern shall include sample points adjacent to service taps, street intersections, and known branch connections, as well as sampling points over or adjacent to buried service lines at the building wall.

**VII-3.3.3 Utilization.** Good judgment shall be used to determine when available openings (such as manholes, vaults, or valve boxes) are sufficient to provide an adequate survey. When necessary, additional sample points (bar holes) shall be made. Sampling points shall be of sufficient depth to sample directly within the subsurface or substructure atmosphere.

### VII-3.4 Vegetation Survey

**VII-3.4.1 Definition.** This survey uses visual observations to detect abnormal or unusual indications in vegetation.

**VII-3.4.2 Procedure.** All visual indications shall be evaluated using an appropriate detector. Personnel performing these surveys shall have good all-around visibility of the area being surveyed, and their speed of travel

shall be determined by taking into consideration the following:

- (a) system layout
- (b) amount and type of vegetation
- (c) visibility conditions (such as lighting, reflected light, distortions, terrain, or obstructions)

**VII-3.4.3 Utilization.** This survey method shall be limited to areas where adequate vegetation growth is firmly established. This survey shall not be conducted under the following conditions:

- (a) soil moisture content abnormally high
- (b) vegetation dormant
- (c) vegetation in an accelerated growth period, such as in early spring

Other acceptable survey methods shall be used for locations within a vegetation survey area where vegetation is not adequate to indicate the presence of leakage.

### VII-3.5 Pressure Drop Test

**VII-3.5.1 Definition.** This is a test to determine if an isolated segment of pipeline loses pressure due to leakage.

**VII-3.5.2 Procedure.** Facilities selected for pressure drop tests shall first be isolated and then tested. The following criteria shall be considered in determining test parameters:

- (a) *Test Pressure.* A test conducted on existing facilities solely to detect leakage shall be performed at a pressure at least equal to the operating pressure.
- (b) *Test Medium.* The test medium may be hydrogen, an inert gas, or water.
- (c) *Test Duration.* The duration of the test shall be of sufficient length to detect leakage. The following shall be considered in the determination of the duration:
  - (1) volume under test
  - (2) time required for the test medium to become temperature stabilized
  - (3) sensitivity of the test instrument

**VII-3.5.3 Utilization.** Pressure drop tests shall be used (23) only to establish the presence or absence of a leak on a specifically isolated segment of a pipeline. Normally, this type of test will not provide a leak location; therefore, facilities on which leakage is indicated may require further evaluation by another detection method so that the leak may be located, evaluated, and graded.

### VII-3.6 Bubble Leakage Test

**VII-3.6.1 Definition.** This is the application of soapy water or other bubble-forming solutions on exposed piping to determine the existence of a leak.

**VII-3.6.2 Procedure.** The exposed piping systems shall be reasonably cleaned and completely coated with the solution. Leaks are indicated by the presence of bubbles. The bubble-forming solution shall not be used on piping unless it has been determined by investigation

or test that the piping is adequately resistant to direct contact with the solution.

**VII-3.6.3 Utilization.** The test method may be used for the following:

(a) testing exposed aboveground portions of a system (such as meter set assemblies or exposed piping or bridge crossing)

(b) testing a tie-in joint or leak repair that is not included in a pressure test

### VII-3.7 Ultrasonic Leakage Test

**VII-3.7.1 Definition.** This is the testing of exposed piping facilities with an instrument capable of detecting the ultrasonic energy generated by escaping gas. The instrument used shall be suitable for the pressure involved.

**VII-3.7.2 Procedure.** In the testing of a gas facility by this method, the following shall be considered:

(a) *Line Pressure.* As the line pressure increases, the magnitude of the ultrasonic energy generated by a leak increases.

(b) *Location of Facility.* Objects near or surrounding a facility being tested may reflect or attenuate the ultrasonic energy generated, making it difficult to detect or pinpoint the leak.

(c) *Leak Frequency.* A number of leaks in a given area can create a high ultrasonic background level that may reduce the detection capabilities of this type of test.

(d) *Type of Facility.* Pneumatic and gas-operated equipment generate ultrasonic energy. The location and amount of this type of equipment shall be known to determine if the ultrasonic background is too high. Personnel conducting this test shall scan the entire area to eliminate the tracking of reflected indications. Ultrasonic indications of leakage shall be verified and/or pinpointed by one of the other acceptable survey or test methods.

**VII-3.7.3 Utilization.** The ultrasonic test may be used for the testing of exposed piping facilities; however, if the ultrasonic background level produces a full-scale meter reading with the gain set at midrange, the facility shall be tested by some other survey method.

## VII-4 INSTRUMENTS FOR THE DETECTION OF GAS

### VII-4.1 Maintenance of Instruments

Each instrument used for leak detection and evaluation shall be operated in accordance with the manufacturer's recommended operating instructions and tested daily or prior to use to ensure proper operation.

### VII-4.2 Calibration of Instruments

Each instrument used for leak detection and evaluation shall be calibrated in accordance with the manufacturer's recommended calibration instructions as follows:

(a) after any repair or replacement of parts.

(b) on a regular schedule, giving consideration to the type and usage of the instrument involved. Gas detectors shall be checked for calibration at least once each month while in use.

(c) at any time it is suspected that the instrument's calibration has changed.

## VII-5 LEAKAGE CLASSIFICATION AND ACTION CRITERIA

### VII-5.1 General

This section establishes a procedure by which leakage indications of flammable gas can be graded and controlled. When evaluating any hydrogen gas leak indication, the preliminary step is to determine the perimeter of the leak area. When this perimeter extends to a building wall, the investigation shall continue into the building.

### VII-5.2 Leak Grades

Based on an evaluation of the location or magnitude of a leak, or both, one of the following leak grades shall be assigned, thereby establishing the leak repair priority:

(a) Grade 1 is a leak that represents an existing or probable hazard to persons or property and requires immediate repair or continuous action until the conditions are no longer hazardous.

(b) Grade 2 is a leak that is recognized as being non-hazardous at the time of detection, but requires scheduled repair based on probable future hazard.

(c) Grade 3 is a leak that is nonhazardous at the time of detection and can be reasonably expected to remain non-hazardous.

### VII-5.3 Leak Classification and Action Criteria

Criteria for leak classification and leakage control are provided in [Tables VII-5.3-1](#), [VII-5.3-2](#), and [VII-5.3-3](#). The examples of leak conditions provided in the tables are presented as guidelines and are not exclusive. The judgment of the operating company personnel at the scene is of primary importance in determining the grade assigned to a leak.

### VII-5.4 Reevaluation of a Leak

When a leak is to be reevaluated (see action criteria in [Tables VII-5.3-2](#) and [VII-5.3-3](#)), it shall be classified using the same criteria as when the leak was first discovered.

**Table VII-5.3-1  
Leak Classification and Action Criteria: Grade 1**

| Grade | Definition  | Action Criteria   | Examples   |
|-------|---|---|--|
| 1     | A leak that represents an existing or probable hazard to persons or property, and requires immediate repair or continuous action until the conditions are no longer hazardous | Requires <i>prompt action</i> [Note (1)] to protect life and property, and continuous action until the conditions are no longer hazardous | (1) Any leak that, in the judgment of operating personnel at the scene, is regarded as an immediate hazard<br>(2) Escaping gas that has ignited<br>(3) Any indication of gas that has migrated into or under a building or into a tunnel<br>(4) Any reading at the outside wall of a building, or where gas would likely migrate to an outside wall of a building<br>(5) Any reading of 80% LEL or greater in an enclosed space<br>(6) Any reading of 80% LEL or greater in small substructures from which gas would likely migrate to the outside wall of a building<br>(7) Any leak that can be seen, heard, or felt, and that is in a location that may endanger the general public or property |

NOTE: (1) The prompt action in some instances may require one or more of the following:

- (a) implementing company emergency plan (see para. GR-5.2.2)
- (b) evacuating premises
- (c) blocking off an area
- (d) rerouting traffic
- (e) eliminating sources of ignition
- (f) venting the area
- (g) stopping the flow of gas by closing valves or other means
- (h) notifying police and fire departments

**Table VII-5.3-2  
Leak Classification and Action Criteria: Grade 2**

| Grade | Definition   | Action Criteria   | Examples   |
|-------|--|---|--|
| 2     | A leak that is nonhazardous at the time of detection, but justifies scheduled repair based on probable future hazard | <p>Leaks shall be repaired or cleared within 1 calendar year, but no later than 15 months from the date the leak was reported. In determining the repair priority, criteria such as the following shall be considered:</p> <ul style="list-style-type: none"> <li>(a) amount and migration of gas</li> <li>(b) proximity of gas to buildings and subsurface structures</li> <li>(c) extent of pavement</li> <li>(d) soil type and soil conditions (such as frost cap, moisture, and natural venting)</li> </ul> <p>Grade 2 leaks shall be reevaluated at least once every 6 months until cleared. The frequency of reevaluation shall be determined by the location and magnitude of the leakage condition.</p> <p>Grade 2 leaks may vary greatly in degree of potential hazard. Some Grade 2 leaks, when evaluated by the above criteria, may justify scheduled repair within the next 5 working days. Others will justify repair within 30 days. During the working day on which the leak is discovered, these situations shall be brought to the attention of the individual responsible for scheduling leak repair.</p> <p>On the other hand, many Grade 2 leaks, because of their location and magnitude, can be scheduled for repair on a normal routine basis with periodic reinspection as necessary.</p> | <p>(1) Leaks requiring action ahead of ground freezing or other adverse changes in venting conditions. Any leak that, under frozen or other adverse soil conditions, would likely migrate to a building.</p> <p>(2) Leaks requiring action within 6 months</p> <ul style="list-style-type: none"> <li>(a) any reading of 40% LEL or greater under a sidewalk in a wall-to-wall paved area that does not qualify as a Grade 1 leak</li> <li>(b) any reading of 100% LEL or greater under a street in a wall-to-wall paved area that has significant gas migration and does not qualify as a Grade 1 leak</li> <li>(c) any reading less than 80% LEL in small substructures from which gas would likely migrate, creating a probable future hazard</li> <li>(d) any reading between 20% LEL and 80% LEL in an enclosed space</li> <li>(e) any reading on a pipeline operating at hoop stress levels of 30% SMYS or greater, in a Class 3 or 4 location, that does not qualify as a Grade 1 leak</li> <li>(f) any leak that, in the judgment of operating company personnel at the scene, is of sufficient magnitude to justify scheduled repair</li> </ul> |

**Table VII-5.3-3  
Leak Classification and Action Criteria: Grade 3**

| Grade | Definition   | Action Criteria  | Examples  |
|-------|--|--|---|
| 3     | A leak that is nonhazardous at the time of detection and can be reasonably expected to remain nonhazardous | These leaks shall be reevaluated during the next scheduled survey or within 15 months of the date reported, whichever occurs first | Leaks requiring reevaluation at periodic intervals<br>(1) any reading of less than 20% LEL in an enclosed space<br>(2) any outdoor readings where it is unlikely that the gas could migrate to a building |

## VII-6 PINPOINTING

### VII-6.1 Scope

Pinpointing is a systematic process of tracing a detected hydrogen gas leak to its source.

### VII-6.2 Procedure

(a) Determine the migration of gas by establishing the outer boundaries of the indications. This will define the area in which the leak will normally be located. These tests shall be made with a gas detector without expending excessive effort providing sample points.

(b) Locate all gas lines to narrow the area of a search, giving particular attention to the location of valves, fittings, tees, and stubs. Connections have a relatively high probability of leakage. Caution shall be exercised to prevent damage to other underground structures during barring or excavating.

(c) Identify foreign facilities in the area of search. Look for evidence of recent construction activities that could have contributed to the leakage. Hydrogen gas may also migrate and vent along a trench provided for other utilities.

(d) Place evenly spaced bar or test holes over the suspected leaking gas line and trace the gas to its source by identifying the test holes with the highest readings. All bar holes shall be of equal depth and diameter, and down to the pipe depth where necessary, to obtain consistent and worthwhile readings. All gas detector readings shall be taken at an equal depth. Only the highest sustained readings shall be utilized.

(e) High readings are found frequently in more than one adjacent bar hole, and additional techniques are necessary to determine which reading is closest to the probable source. Many of the bar hole readings will normally decline over a period of time, but it may be desirable to dissipate excess hydrogen gas from the underground locations to hasten this process. Evaluation methods shall be

used with caution to avoid the distorting of the venting patterns.

(f) Once the underground leakage has been identified, additional holes and deeper holes shall be probed to bracket the area more closely. For example, test holes may be spaced 2 m (6 ft) apart initially. The 2-m (6-ft) spacing between the two highest test holes might then be probed with additional test holes with spacing as close as 300 mm (12 in.).

(g) Additional tests include taking gas detector readings at the top of a bar hole or using a manometer or bubble-forming solution to determine which bar hole has the greatest positive flow. Other indications are dust particles blowing from the bar holes, the sound of gas coming from the bar hole, or the feel of gas flow on a sensitive skin surface. On occasion, sunlight diffraction can be observed as the hydrogen gas vents to the atmosphere.

(h) When hydrogen gas is found in an underground conduit, tests at available openings may be used to isolate the source, in addition to the techniques previously mentioned. Many times the leak is found at the intersection of the foreign conduit and a hydrogen gas line, and particular attention shall be given to these locations.

(i) When the pattern of the gas detector readings has stabilized, the bar hole with the highest reading will usually pinpoint the leak.

(j) When and where piping has been exposed, test with bubble-forming solution, particularly to locate smaller leaks.

### VII-6.3 Precautions

Unusual situations, which are unlikely but possible, may complicate these techniques. For example, multiple leaks, which give confusing data, can occur. To eliminate this potential complication, the area shall be rechecked after repairs are completed. Hydrogen gas may occasionally form pockets and give a strong indication until the cavity in which the pocket has formed has been vented.

# MANDATORY APPENDIX IX

## ALLOWABLE STRESSES AND QUALITY FACTORS FOR METALLIC PIPING, PIPELINE, AND BOLTING MATERIALS

### (23) IX-1 INTRODUCTION

This Appendix contains the following tables:

- (a) [Table IX-1A](#) for basic allowable stresses and [Table IX-1B](#) for specified minimum yield strengths
- (b) [Table IX-2](#), Basic Casting Quality Factors,  $E_c$
- (c) [Tables IX-3A](#) and [IX-3B](#) for longitudinal joints factors
- (d) [Table IX-4](#), Design Stress Values for Bolting Materials
- (e) [Tables IX-5A](#) through [IX-5C](#) for material performance factors

### IX-2 TABLE IX-1

This table is split into two tables by usage: [Table IX-1A](#), Basic Allowable Stresses in Tension for Metal Piping Materials; and [Table IX-1B](#), Specified Minimum Yield Strength for Steel Pipe Commonly Used in Pipeline Systems.

The specifications noted are either ASTM or API standards. The material classifications listed include the following:

- (a) carbon steel
  - (1) pipes and tubes
  - (2) pipes (structural grade)
  - (3) plates and sheets
  - (4) plates and sheets (structural)
  - (5) forgings and fittings
  - (6) castings
- (b) low and intermediate alloy steel
  - (1) pipes
  - (2) plates
  - (3) forgings and fittings
  - (4) castings
- (c) stainless steel
  - (1) pipes and tubes
  - (2) plates and sheets
  - (3) forgings and fittings
  - (4) bar
  - (5) castings
- (d) copper and copper alloys
  - (1) pipes and tubes
  - (2) plates and sheets
  - (3) forgings
  - (4) castings

(e) nickel and nickel alloy

- (1) pipes and tubes
- (2) plates and sheets
- (3) forgings and fittings
- (4) rod and bar
- (f) aluminum alloys
  - (1) seamless pipes and tubes
  - (2) welded pipes and tubes
  - (3) structural tubes
  - (4) plates and sheets
  - (5) forgings and fittings
  - (6) castings

### IX-3 TABLE IX-3

This table is split into two tables by usage: [Table IX-3A](#), Basic Quality Factors for Longitudinal Weld Joints in Pipes, Tubes, and Fittings,  $E_j$ ; and [Table IX-3B](#), Longitudinal Joints Factors for Pipeline Materials.

The specifications noted are either ASTM or API standards. The material classifications listed include the following:

- (a) steel
  - (1) carbon steel
  - (2) low and intermediate alloy steel
  - (3) stainless steel
- (b) copper and copper alloys
- (c) nickel and nickel alloys
- (d) aluminum alloys

### IX-4 TABLE IX-4

This table covers design stress values for bolting materials.

### IX-5 TABLE IX-5

This table is split into the following three tables by usage:

- (a) [Table IX-5A](#), Carbon Steel Pipeline Materials Performance Factor,  $H_f$
- (b) [Table IX-5B](#), Carbon Steel Piping Materials Performance Factor,  $M_f$
- (c) [Table IX-5C](#), Low and Intermediate Alloy Steels Performance Factor,  $M_f$

TABLE STARTS ON NEXT PAGE



(23)

**Table IX-1A  
Basic Allowable Stresses in Tension for Metal Piping Materials**

Specifications Are ASTM Unless Otherwise Indicated

| Material   | Spec. No.      | P-No.<br>[Note (1)] | Grade      | Notes                                | Min.<br>Temp., °F<br>[Note (2)] | Specified Min.<br>Strength, ksi |       | Basic Allowable<br>Stress, S, ksi<br>[Note (3)], at Metal<br>Temperature, °F |      |      |
|--|----------------|---------------------|------------|--------------------------------------|---------------------------------|---------------------------------|-------|--|------|------|
|  |                |                     |            |                                      |                                 | Tensile                         | Yield | Min.<br>Temp.<br>to 100  | 200  | 300  |
| <b>Carbon Steel — Pipes and Tubes [Note (5)]</b> |                |                     |            |                                      |                                 |                                 |       |  |      |      |
| A285 Gr. A<br>Smls & ERW                         | A672<br>API 5L | 1                   | A45<br>A25 | (38) (40) (44)<br>(4) (38) (40) (50) | B                               | 45                              | 24    | 15.0   | 14.6 | 14.2 |
| ...  | A179           | 1                   | ...        | (38) (40)                            | -20                             | 47                              | 26    | 15.7   | 15.0 | 14.2 |
| ...  | A139           | 1                   | A          | (10b) (50)                           | A                               | 48                              | 30    | 16.0   | 16.0 | 16.0 |
| ...  | A587           | 1                   | ...        | (38) (40)                            | -20                             | 48                              | 30    | 16.0   | 16.0 | 16.0 |
| ...  | A53            | 1                   | A          | (4) (38) (40)                        | B                               | 48                              | 30    | 16.0   | 16.0 | 16.0 |
| ...  | A106           | 1                   | A          | (38)                                 | B                               | 48                              | 30    | 16.0   | 16.0 | 16.0 |
| ...  | A135           | 1                   | A          | (38) (40)                            | B                               | 48                              | 30    | 16.0   | 16.0 | 16.0 |
| ...  | A369           | 1                   | FPA        | (38)                                 | B                               | 48                              | 30    | 16.0   | 16.0 | 16.0 |
| ...  | API 5L         | 1                   | A          | (4) (38) (40) (50)                   | B                               | 48                              | 30    | 16.0   | 16.0 | 16.0 |
| A285 Gr. B                                       | A672           | 1                   | A50        | (38) (40) (44)                       | B                               | 50                              | 27    | 16.7   | 16.5 | 15.9 |
| ...  | A524           | 1                   | II         | (38)                                 | -20                             | 55                              | 30    | 18.3   | 18.3 | 17.7 |
| ...  | A333           | 1                   | 1          | (38) (40)                            | -50                             | 55                              | 30    | 18.3   | 18.3 | 17.7 |
| ...  | A334           | 1                   | 1          | (38) (40)                            | -50                             | 55                              | 30    | 18.3   | 18.3 | 17.7 |
| A285 Gr. C                                       | A671           | 1                   | CA55       | (40) (44)                            | A                               | 55                              | 30    | 18.3   | 18.3 | 17.7 |
| A285 Gr. C                                       | A672           | 1                   | A55        | (38) (40) (44)                       | A                               | 55                              | 30    | 18.3   | 18.3 | 17.7 |
| A516 Gr. 55                                      | A672           | 1                   | C55        | (38) (44)                            | C                               | 55                              | 30    | 18.3   | 18.3 | 17.7 |
| A516 Gr. 60                                      | A671           | 1                   | CC60       | (38) (44)                            | C                               | 60                              | 32    | 20.0   | 19.5 | 18.9 |
| A516 Gr. 60                                      | A672           | 1                   | C60        | (38) (44)                            | C                               | 60                              | 32    | 20.0   | 19.5 | 18.9 |
| ...  | A139           | 1                   | B          | (10b)                                | A                               | 60                              | 35    | 20.0   | 20.0 | 20.0 |
| ...  | A135           | 1                   | B          | (38) (40)                            | B                               | 60                              | 35    | 20.0   | 20.0 | 20.0 |
| ...  | A524           | 1                   | I          | (38)                                 | -20                             | 60                              | 35    | 20.0   | 20.0 | 20.0 |
| ...  | A53            | 1                   | B          | (4) (38) (40)                        | B                               | 60                              | 35    | 20.0   | 20.0 | 20.0 |
| ...  | A106           | 1                   | B          | (38)                                 | B                               | 60                              | 35    | 20.0   | 20.0 | 20.0 |
| ...  | A333           | 1                   | 6          | (38)                                 | -50                             | 60                              | 35    | 20.0   | 20.0 | 20.0 |
| ...  | A334           | 1                   | 6          | (38)                                 | -50                             | 60                              | 35    | 20.0   | 20.0 | 20.0 |
| ...  | A369           | 1                   | FPB        | (38)                                 | -20                             | 60                              | 35    | 20.0   | 20.0 | 20.0 |
| ...  | A381           | 1                   | Y35        | ...                                  | A                               | 60                              | 35    | 20.0   | 20.0 | 20.0 |
| ...  | API 5L         | 1                   | B          | (4) (38) (40) (50)                   | B                               | 60                              | 35    | 20.0   | 20.0 | 20.0 |
| ...  | A139           | 1                   | C          | (10b)                                | A                               | 60                              | 42    | 20.0   | 20.0 | 20.0 |
| ...  | A139           | 1                   | D          | (10b)                                | A                               | 60                              | 46    | 20.0   | 20.0 | 20.0 |
| ...  | API 5L         | 1                   | X42        | (4) (36) (50)                        | A                               | 60                              | 42    | 20.0   | 20.0 | 20.0 |
| ...  | A381           | 1                   | Y42        | ...                                  | A                               | 60                              | 42    | 20.0   | 20.0 | 20.0 |
| ...  | A381           | 1                   | Y48        | ...                                  | A                               | 62                              | 48    | 20.7   | 20.7 | 20.7 |
| ...  | A381           | 1                   | Y46        | ...                                  | A                               | 63                              | 46    | 21.0   | 21.0 | 21.0 |

**Table IX-1A**  
**Basic Allowable Stresses in Tension for Metal Piping Materials**  
 Specifications Are ASTM Unless Otherwise Indicated

| Basic Allowable Stress, S, ksi [Note (3)], at Metal Temperature, °F |      |      |      |      |      |      |     |     |     |       |       |           |
|---|------|------|------|------|------|------|-----|-----|-----|-------|-------|-----------|
| 400   | 500  | 600  | 650  | 700  | 750  | 800  | 850 | 900 | 950 | 1,000 | Grade | Spec. No. |
| <b>Carbon Steel — Pipes and Tubes [Note (5)]</b>                    |      |      |      |      |      |      |     |     |     |       |       |           |
| 13.7  | 13.0 | 12.3 | 11.9 | 11.5 | 10.7 | 9.2  | 7.8 | 5.9 | 4.0 | 2.5   | A45   | A672      |
| 14.2  | ...  | ...  | ...  | ...  | ...  | ...  | ... | ... | ... | ...   | A25   | API 5L    |
| 14.8  | 14.1 | 13.3 | 12.8 | 12.4 | 10.7 | 9.2  | 7.9 | 5.9 | 4.0 | 2.5   | ...   | A179      |
| ...   | ...  | ...  | ...  | ...  | ...  | ...  | ... | ... | ... | ...   | A     | A139      |
| 16.0  | 16.0 | 15.3 | 14.6 | 12.5 | 10.7 | 9.2  | 7.9 | ... | ... | ...   | ...   | A587      |
| 16.0  | 16.0 | 15.3 | 14.6 | 12.5 | 10.7 | 9.2  | 7.9 | 5.9 | 4.0 | 2.5   | A     | A53       |
| 16.0  | 16.0 | 15.3 | 14.6 | 12.5 | 10.7 | 9.2  | 7.9 | 5.9 | 4.0 | 2.5   | A     | A106      |
| 16.0  | 16.0 | 15.3 | 14.6 | 12.5 | 10.7 | 9.2  | 7.9 | 5.9 | 4.0 | 2.5   | A     | A135      |
| 16.0  | 16.0 | 15.3 | 14.6 | 12.5 | 10.7 | 9.2  | 7.9 | 5.9 | 4.0 | 2.5   | FPA   | A369      |
| 16.0  | 16.0 | 15.3 | 14.6 | 12.5 | 10.7 | 9.2  | 7.9 | 5.9 | 4.0 | 2.5   | A     | API 5L    |
| 15.4  | 14.7 | 13.8 | 13.3 | 12.5 | 10.7 | 9.2  | 7.9 | 5.9 | 4.0 | 2.5   | A50   | A672      |
| 17.1  | 16.3 | 15.3 | 14.8 | 14.3 | 13.0 | 10.8 | 8.7 | 5.9 | 4.0 | 2.5   | II    | A524      |
| 17.1  | 16.3 | 15.3 | 14.8 | 14.3 | 13.0 | 10.8 | 8.7 | 5.9 | 4.0 | 2.5   | 1     | A333      |
| 17.1  | 16.3 | 15.3 | 14.8 | 14.3 | 13.0 | 10.8 | 8.7 | 5.9 | 4.0 | 2.5   | 1     | A334      |
| 17.1  | 16.3 | 15.3 | 14.8 | 14.3 | 13.0 | 10.8 | 8.7 | 5.9 | 4.0 | 2.5   | CA55  | A671      |
| 17.1  | 16.3 | 15.3 | 14.8 | 14.3 | 13.0 | 10.8 | 8.7 | 5.9 | 4.0 | 2.5   | A55   | A672      |
| 17.1  | 16.3 | 15.3 | 14.8 | 14.3 | 13.0 | 10.8 | 8.7 | 5.9 | 4.0 | 2.5   | C55   | A672      |
| 18.2  | 17.4 | 16.4 | 15.8 | 15.3 | 13.9 | 11.4 | 8.7 | 5.9 | 4.0 | 2.5   | CC60  | A671      |
| 18.2  | 17.4 | 16.4 | 15.8 | 15.3 | 13.9 | 11.4 | 8.7 | 5.9 | 4.0 | 2.5   | C60   | A672      |
| ...   | ...  | ...  | ...  | ...  | ...  | ...  | ... | ... | ... | ...   | B     | A139      |
| 19.9  | 19.0 | 17.9 | 17.3 | 16.7 | 13.9 | 11.4 | 8.7 | 5.9 | 4.0 | 2.5   | B     | A135      |
| 19.9  | 19.0 | 17.9 | 17.3 | 16.7 | 13.9 | 11.4 | 8.7 | 5.9 | 4.0 | 2.5   | I     | A524      |
| 19.9  | 19.0 | 17.9 | 17.3 | 16.7 | 13.9 | 11.4 | 8.7 | 5.9 | 4.0 | 2.5   | B     | A53       |
| 19.9  | 19.0 | 17.9 | 17.3 | 16.7 | 13.9 | 11.4 | 8.7 | 5.9 | 4.0 | 2.5   | B     | A106      |
| 19.9  | 19.0 | 17.9 | 17.3 | 16.7 | 13.9 | 11.4 | 8.7 | 5.3 | 4.0 | 2.5   | 6     | A333      |
| 19.9  | 19.0 | 17.9 | 17.3 | 16.7 | 13.9 | 11.4 | 8.7 | 5.9 | 4.0 | 2.5   | 6     | A334      |
| 19.9  | 19.0 | 17.9 | 17.3 | 16.7 | 13.9 | 11.4 | 8.7 | 5.9 | 4.0 | 2.5   | FPB   | A369      |
| 19.9  | 19.0 | 17.9 | 17.3 | 16.7 | 13.9 | 11.4 | 8.7 | 5.9 | 4.0 | 2.5   | Y35   | A381      |
| 19.9  | 19.0 | 17.9 | 17.3 | 16.7 | 13.9 | 11.4 | 8.7 | 5.9 | 4.0 | 2.5   | B     | API 5L    |
| ...   | ...  | ...  | ...  | ...  | ...  | ...  | ... | ... | ... | ...   | C     | A139      |
| ...   | ...  | ...  | ...  | ...  | ...  | ...  | ... | ... | ... | ...   | D     | A139      |
| 20.0  | ...  | ...  | ...  | ...  | ...  | ...  | ... | ... | ... | ...   | X42   | API 5L    |
| 20.0  | ...  | ...  | ...  | ...  | ...  | ...  | ... | ... | ... | ...   | Y42   | A381      |
| 20.7  | 20.7 | 20.7 | 18.7 | ...  | ...  | ...  | ... | ... | ... | ...   | Y48   | A381      |
| 21.0  | ...  | ...  | ...  | ...  | ...  | ...  | ... | ... | ... | ...   | Y46   | A381      |

**Table IX-1A**  
**Basic Allowable Stresses in Tension for Metal Piping Materials (Cont'd)**

Specifications Are ASTM Unless Otherwise Indicated

| Material  | Spec. No. | P-No.<br>[Note (1)] | Grade  | Notes                   | Min.<br>Temp., °F<br>[Note (2)] | Specified Min.<br>Strength, ksi |       | Basic Allowable<br>Stress, S, ksi<br>[Note (3)], at Metal<br>Temperature, °F |      |      |
|---|-----------|---------------------|--------|-------------------------|---------------------------------|---------------------------------|-------|--|------|------|
|   |           |                     |        |                         |                                 | Tensile                         | Yield | Min.<br>Temp.<br>to 100  | 200  | 300  |
| <b>Carbon Steel — Pipes and Tubes [Note (5)]</b>          |           |                     |        |                         |                                 |                                 |       |  |      |      |
| ...   | A381      | 1                   | Y50    | ...                     | A                               | 64                              | 50    | 21.3   | 21.3 | 21.3 |
| A516 Gr. 65   | A671      | 1                   | CC65   | (38) (44)               | B                               | 65                              | 35    | 21.7   | 21.4 | 20.6 |
| A516 Gr. 65   | A672      | 1                   | C65    | (38) (44)               | B                               | 65                              | 35    | 21.7   | 21.4 | 20.6 |
| ...   | A139      | 1                   | E      | (10b)                   | A                               | 66                              | 52    | 22.0   | 22.0 | 22.0 |
| ...   | API 5L    | 1                   | X52    | (4) (36) (50)           | A                               | 66                              | 52    | 22.0   | 22.0 | 22.0 |
| ...   | A381      | 1                   | Y52    | ...                     | A                               | 66                              | 52    | 22.0   | 22.0 | 22.0 |
| A516 Gr. 70   | A671      | 1                   | CC70   | (38) (44)               | B                               | 70                              | 38    | 23.3   | 23.2 | 22.4 |
| A516 Gr. 70   | A672      | 1                   | C70    | (38) (44)               | B                               | 70                              | 38    | 23.3   | 23.2 | 22.4 |
| ...   | A106      | 1                   | C      | (38)                    | B                               | 70                              | 40    | 23.3   | 23.3 | 23.3 |
| A537 Cl. 1 (≤2½ in. thick)                                | A671      | 1                   | CD70   | (44)                    | D                               | 70                              | 50    | 23.3   | 23.3 | 22.8 |
| A537 Cl. 1 (≤2½ in. thick)                                | A672      | 1                   | D70    | (44)                    | D                               | 70                              | 50    | 23.3   | 23.3 | 22.8 |
| A537 Cl. 1 (≤2½ in. thick)                                | A691      | 1                   | CMSH70 | (44)                    | D                               | 70                              | 50    | 23.3   | 23.3 | 22.8 |
| ...   | API 5L    | 1                   | X56    | (4) (34) (36) (47) (50) | A                               | 71                              | 56    | 23.7   | 23.7 | 23.7 |
| ...   | A381      | 1                   | Y56    | (34) (36) (47)          | A                               | 71                              | 56    | 23.7   | 23.7 | 23.7 |
| A299 (>1 in. thick)                                       | A671      | 1                   | CK75   | (38) (44)               | A                               | 75                              | 40    | 25.0   | 24.4 | 23.6 |
| A299 (>1 in. thick)                                       | A672      | 1                   | N75    | (38) (44)               | A                               | 75                              | 40    | 25.0   | 24.4 | 23.6 |
| A299 (>1 in. thick)                                       | A691      | 1                   | CMS75  | (38) (44)               | A                               | 75                              | 40    | 25.0   | 24.4 | 23.6 |
| A299 (≤1 in. thick)                                       | A671      | 1                   | CK75   | (38) (44)               | A                               | 75                              | 40    | 25.0   | 25.0 | 24.8 |
| A299 (≤1 in. thick)                                       | A672      | 1                   | N75    | (38) (44)               | A                               | 75                              | 40    | 25.0   | 25.0 | 24.8 |
| A299 (≤1 in. thick)                                       | A691      | 1                   | CMS75  | (38) (44)               | A                               | 75                              | 40    | 25.0   | 25.0 | 24.8 |
| ...   | API 5L    | 1                   | X60    | (4) (34) (36) (47) (50) | A                               | 75                              | 60    | 25.0   | 25.0 | 25.0 |
| ...   | API 5L    | 1                   | X65    | (4) (34) (36) (47) (50) | A                               | 77                              | 65    | 25.7   | 25.7 | 25.7 |
| ...   | API 5L    | 1                   | X70    | (4) (34) (36) (47) (50) | A                               | 82                              | 70    | 27.3   | 27.3 | 27.3 |
| ...   | API 5L    | 1                   | X80    | (4) (34) (36) (47) (50) | A                               | 90                              | 80    | 30.0   | 30.0 | 30.0 |
| ...   | A381      | 1                   | Y60    | (34) (47)               | A                               | 75                              | 60    | 25.0   | 25.0 | 25.0 |
| <b>Carbon Steel — Pipes (Structural Grade) [Note (5)]</b> |           |                     |        |                         |                                 |                                 |       |  |      |      |
| A1011 Gr. 33  | A134      | 1                   | ...    | (10a) (10c)             | -20                             | 52                              | 33    | 17.3   | 17.3 | 17.3 |
| A1011 Gr. 36 Type 1                                       | A134      | 1                   | ...    | (10a) (10c)             | -20                             | 53                              | 36    | 17.7   | 17.7 | 17.7 |
| A1011 Gr. 40  | A134      | 1                   | ...    | (10a) (10c)             | -20                             | 55                              | 40    | 18.3   | 18.3 | 18.3 |
| A1011 Gr. 45  | A134      | 1                   | ...    | (10a) (10c)             | -20                             | 60                              | 45    | 20.0   | 20.0 | 20.0 |
| A1011 Gr. 50  | A134      | 1                   | ...    | (10a) (10c)             | -20                             | 65                              | 50    | 21.7   | 21.7 | 21.7 |
| <b>Carbon Steel — Plates and Sheets</b>                   |           |                     |        |                         |                                 |                                 |       |  |      |      |
| ...   | A516      | 1                   | 55     | (38)                    | C                               | 55                              | 30    | 18.3   | 18.3 | 17.7 |
| ...   | A516      | 1                   | 60     | (38)                    | C                               | 60                              | 32    | 20.0   | 19.5 | 18.9 |
| ...   | A516      | 1                   | 65     | (38)                    | B                               | 65                              | 35    | 21.7   | 21.4 | 20.6 |

**Table IX-1A**  
**Basic Allowable Stresses in Tension for Metal Piping Materials (Cont'd)**  
 Specifications Are ASTM Unless Otherwise Indicated

| Basic Allowable Stress, S, ksi [Note (3)], at Metal Temperature, °F |      |      |      |      |      |      |     |     |     |       |        |           |
|---|------|------|------|------|------|------|-----|-----|-----|-------|--------|-----------|
| 400   | 500  | 600  | 650  | 700  | 750  | 800  | 850 | 900 | 950 | 1,000 | Grade  | Spec. No. |
| <b>Carbon Steel — Pipes and Tubes [Note (5)] (Cont'd)</b>           |      |      |      |      |      |      |     |     |     |       |        |           |
| 21.3  | 21.3 | 21.3 | 18.7 | ...  | ...  | ...  | ... | ... | ... | ...   | Y50    | A381      |
| 19.9  | 19.0 | 17.9 | 17.3 | 16.7 | 13.9 | 11.4 | 9.0 | 6.3 | 4.0 | 2.5   | CC65   | A671      |
| 19.9  | 19.0 | 17.9 | 17.3 | 16.7 | 13.9 | 11.4 | 9.0 | 6.3 | 4.0 | 2.5   | C65    | A672      |
| ...   | ...  | ...  | ...  | ...  | ...  | ...  | ... | ... | ... | ...   | E      | A139      |
| 22.0  | ...  | ...  | ...  | ...  | ...  | ...  | ... | ... | ... | ...   | X52    | API 5L    |
| 22.0  | ...  | ...  | ...  | ...  | ...  | ...  | ... | ... | ... | ...   | Y52    | A381      |
| 21.6  | 20.6 | 19.4 | 18.8 | 18.1 | 14.8 | 12.0 | 9.3 | 6.3 | 4.0 | 2.5   | CC70   | A671      |
| 21.6  | 20.6 | 19.4 | 18.8 | 18.1 | 14.8 | 12.0 | 9.3 | 6.3 | 4.0 | 2.5   | C70    | A672      |
| 22.8  | 21.7 | 20.4 | 19.8 | 18.3 | 14.8 | 12.0 | ... | ... | ... | ...   | C      | A106      |
| 22.7  | 22.7 | 22.4 | 21.9 | 18.3 | ...  | ...  | ... | ... | ... | ...   | CD70   | A671      |
| 22.7  | 22.7 | 22.4 | 21.9 | 18.3 | ...  | ...  | ... | ... | ... | ...   | D70    | A672      |
| 22.7  | 22.7 | 22.4 | 21.9 | 18.3 | ...  | ...  | ... | ... | ... | ...   | CMSH70 | A691      |
| 23.7  | ...  | ...  | ...  | ...  | ...  | ...  | ... | ... | ... | ...   | X56    | API 5L    |
| 23.7  | ...  | ...  | ...  | ...  | ...  | ...  | ... | ... | ... | ...   | Y56    | A381      |
| 22.8  | 21.7 | 20.4 | 19.8 | 19.1 | 15.7 | 12.6 | 9.3 | 6.7 | 4.0 | 2.5   | CK75   | A671      |
| 22.8  | 21.7 | 20.4 | 19.8 | 19.1 | 15.7 | 12.6 | 9.3 | 6.7 | 4.0 | 2.5   | N75    | A672      |
| 22.8  | 21.7 | 20.4 | 19.8 | 19.1 | 15.7 | 12.6 | 9.3 | 6.7 | 4.0 | 2.5   | CMS75  | A691      |
| 23.9  | 22.8 | 21.5 | 20.8 | 19.6 | ...  | ...  | ... | ... | ... | ...   | CK75   | A671      |
| 23.9  | 22.8 | 21.5 | 20.8 | 19.6 | ...  | ...  | ... | ... | ... | ...   | N75    | A672      |
| 23.9  | 22.8 | 21.5 | 20.8 | 19.6 | ...  | ...  | ... | ... | ... | ...   | CMS75  | A691      |
| 25.0  | ...  | ...  | ...  | ...  | ...  | ...  | ... | ... | ... | ...   | X60    | API 5L    |
| 25.7  | ...  | ...  | ...  | ...  | ...  | ...  | ... | ... | ... | ...   | X65    | API 5L    |
| 27.3  | ...  | ...  | ...  | ...  | ...  | ...  | ... | ... | ... | ...   | X70    | API 5L    |
| 30.0  | ...  | ...  | ...  | ...  | ...  | ...  | ... | ... | ... | ...   | X80    | API 5L    |
| 25.0  | ...  | ...  | ...  | ...  | ...  | ...  | ... | ... | ... | ...   | Y60    | A381      |
| <b>Carbon Steel — Pipes (Structural Grade) [Note (5)]</b>           |      |      |      |      |      |      |     |     |     |       |        |           |
| 17.3  | ...  | ...  | ...  | ...  | ...  | ...  | ... | ... | ... | ...   | ...    | A134      |
| 17.7  | ...  | ...  | ...  | ...  | ...  | ...  | ... | ... | ... | ...   | ...    | A134      |
| 18.3  | ...  | ...  | ...  | ...  | ...  | ...  | ... | ... | ... | ...   | ...    | A134      |
| 20.0  | ...  | ...  | ...  | ...  | ...  | ...  | ... | ... | ... | ...   | ...    | A134      |
| 21.7  | ...  | ...  | ...  | ...  | ...  | ...  | ... | ... | ... | ...   | ...    | A134      |
| <b>Carbon Steel — Plates and Sheets</b>                             |      |      |      |      |      |      |     |     |     |       |        |           |
| 17.1  | 16.3 | 15.3 | 14.8 | 14.3 | 13.0 | 10.8 | 8.7 | ... | ... | ...   | 55     | A516      |
| 18.2  | 17.4 | 16.4 | 15.8 | 15.3 | 13.9 | 11.4 | 8.7 | ... | ... | ...   | 60     | A516      |
| 19.9  | 19.0 | 17.9 | 17.3 | 16.7 | 13.9 | 11.4 | 9.0 | ... | ... | ...   | 65     | A516      |

**Table IX-1A**  
**Basic Allowable Stresses in Tension for Metal Piping Materials (Cont'd)**

Specifications Are ASTM Unless Otherwise Indicated

| Material   | Spec. No. | P-No.<br>[Note (1)] | Grade  | Notes          | Min.<br>Temp., °F<br>[Note (2)] | Specified Min.<br>Strength, ksi |       | Basic Allowable<br>Stress, S, ksi<br>[Note (3)], at Metal<br>Temperature, °F |      |      |
|--|-----------|---------------------|--------|----------------|---------------------------------|---------------------------------|-------|--|------|------|
|  |           |                     |        |                |                                 | Tensile                         | Yield | Min.<br>Temp.<br>to 100  | 200  | 300  |
| <b>Carbon Steel — Plates and Sheets</b>                  |           |                     |        |                |                                 |                                 |       |  |      |      |
| ...  | A516      | 1                   | 70     | (38)           | B                               | 70                              | 38    | 23.2   | 23.2 | 22.4 |
| (≤2½ in. thick)  | A537      | 1                   | Cl. 1  | ...            | D                               | 70                              | 50    | 23.3   | 23.3 | 22.8 |
| (>1 in. thick)   | A299      | 1                   | ...    | (38)           | A                               | 75                              | 40    | 25.0   | 24.4 | 23.6 |
| (≤1 in. thick)   | A299      | 1                   | ...    | (38)           | A                               | 75                              | 42    | 25.0   | 25.0 | 24.8 |
| <b>Plates and Sheets (Structural)</b>                    |           |                     |        |                |                                 |                                 |       |  |      |      |
| ...  | A1011     | 1                   | 30     | (10c) (38)     | A                               | 49                              | 30    | 16.3   | 16.3 | 16.3 |
| ...  | A1011     | 1                   | 33     | (10c) (38)     | A                               | 52                              | 33    | 17.3   | 17.3 | 17.3 |
| ...  | A1011     | 1                   | 36     | (10c) (38)     | A                               | 53                              | 36    | 17.7   | 17.7 | 17.7 |
| ...  | A1011     | 1                   | 40     | (10c) (38)     | A                               | 55                              | 40    | 18.3   | 18.3 | 18.3 |
| ...  | A36       | 1                   | ...    | (10c) (51)     | A                               | 58                              | 36    | 19.3   | 19.3 | 19.3 |
| ...  | A1011     | 1                   | 45     | (10c) (38)     | A                               | 60                              | 45    | 20.0   | 20.0 | 20.0 |
| ...  | A1011     | 1                   | 50     | (10c) (38)     | A                               | 65                              | 50    | 21.7   | 21.7 | 21.7 |
| <b>Carbon Steel — Forgings and Fittings [Note (5)]</b>   |           |                     |        |                |                                 |                                 |       |  |      |      |
| ...  | A350      | 1                   | LF1    | (11) (38) (40) | -20                             | 60                              | 30    | 20.0   | 18.3 | 17.7 |
| ...  | A181      | 1                   | Cl. 60 | (11) (38) (40) | A                               | 60                              | 30    | 20.0   | 18.3 | 17.7 |
| ...  | A420      | 1                   | WPL6   | (38)           | -50                             | 60                              | 35    | 20.0   | 20.0 | 20.0 |
| ...  | A234      | 1                   | WPB    | (38) (40)      | B                               | 60                              | 35    | 20.0   | 20.0 | 20.0 |
| ...  | A350      | 1                   | LF2    | (11) (38)      | -50                             | 70                              | 36    | 23.3   | 21.9 | 21.3 |
| ...  | A105      | 1                   | ...    | (11) (38) (40) | -20                             | 70                              | 36    | 23.3   | 22.0 | 21.2 |
| ...  | A181      | 1                   | Cl. 70 | (11) (38) (40) | A                               | 70                              | 36    | 23.3   | 22.0 | 21.2 |
| ...  | A234      | 1                   | WPC    | (38) (40)      | B                               | 70                              | 40    | 23.3   | 23.3 | 23.3 |
| <b>Carbon Steel — Castings [Note (5)]</b>                |           |                     |        |                |                                 |                                 |       |  |      |      |
| ...  | A216      | 1                   | WCA    | (38)           | -20                             | 60                              | 30    | 20.0   | 18.3 | 17.7 |
| ...  | A352      | 1                   | LCB    | (11) (38)      | -50                             | 65                              | 35    | 21.7   | 21.4 | 20.6 |
| ...  | A216      | 1                   | WCB    | (11) (38)      | -20                             | 70                              | 36    | 23.3   | 22.0 | 21.2 |
| ...  | A216      | 1                   | WCC    | (11) (38)      | -20                             | 70                              | 40    | 23.3   | 23.3 | 23.3 |
| <b>Low and Intermediate Alloy Steel Pipes [Note (5)]</b> |           |                     |        |                |                                 |                                 |       |  |      |      |
| ½Cr-½Mo  | A335      | 3                   | P2     | ...            | -20                             | 55                              | 30    | 18.3   | 18.3 | 17.5 |
| ½Cr-½Mo A387 Gr. 2 Cl. 1                                 | A691      | 3                   | ½CR    | (13) (44)      | -20                             | 55                              | 33    | 18.3   | 18.3 | 18.3 |
| C-½Mo  | A335      | 3                   | P1     | (39)           | -20                             | 55                              | 30    | 18.3   | 18.3 | 17.5 |
| C-½Mo  | A369      | 3                   | FP1    | (39)           | -20                             | 55                              | 30    | 18.3   | 18.3 | 17.5 |
| ½Cr-½Mo  | A369      | 3                   | FP2    | ...            | -20                             | 55                              | 30    | 18.3   | 18.3 | 17.5 |
| 1Cr-½Mo A387 Gr. 12 Cl. 1                                | A691      | 4                   | 1CR    | (13) (44)      | -20                             | 55                              | 33    | 18.3   | 18.3 | 18.3 |
| ½Cr-½Mo  | A426      | 3                   | CP2    | (12)           | -20                             | 60                              | 30    | 18.4   | 17.7 | 17.0 |

**Table IX-1A**  
**Basic Allowable Stresses in Tension for Metal Piping Materials (Cont'd)**  
 Specifications Are ASTM Unless Otherwise Indicated

| Basic Allowable Stress, S, ksi [Note (3)], at Metal Temperature, °F |      |      |      |      |      |      |      |      |      |       |        |           |
|---|------|------|------|------|------|------|------|------|------|-------|--------|-----------|
| 400   | 500  | 600  | 650  | 700  | 750  | 800  | 850  | 900  | 950  | 1,000 | Grade  | Spec. No. |
| <b>Carbon Steel — Plates and Sheets (Cont'd)</b>                    |      |      |      |      |      |      |      |      |      |       |        |           |
| 21.6  | 20.6 | 19.4 | 18.8 | 18.1 | 14.8 | 12.0 | 9.3  | ...  | ...  | ...   | 70     | A516      |
| 22.7  | 22.7 | 22.4 | 21.9 | 18.3 | ...  | ...  | ...  | ...  | ...  | ...   | Cl. 1  | A537      |
| 22.8  | 21.7 | 20.4 | 19.8 | 19.1 | 15.7 | 12.6 | 9.3  | 6.7  | 4.0  | 2.5   | ...    | A299      |
| 23.9  | 22.8 | 21.5 | 20.8 | 19.6 | 15.7 | 12.6 | 9.3  | 6.7  | 4.0  | 2.5   | ...    | A299      |
| <b>Plates and Sheets (Structural)</b>                               |      |      |      |      |      |      |      |      |      |       |        |           |
| 16.3  | 16.3 | 15.3 | 14.6 | 12.5 | 10.7 | ...  | ...  | ...  | ...  | ...   | 30     | A1011     |
| 17.3  | 17.3 | 16.9 | 14.6 | 12.5 | 10.7 | ...  | ...  | ...  | ...  | ...   | 33     | A1011     |
| 17.7  | 17.7 | 17.7 | 14.6 | 12.5 | 10.7 | ...  | ...  | ...  | ...  | ...   | 36     | A1011     |
| 18.3  | 18.3 | 18.3 | 18.3 | 15.6 | 13.0 | ...  | ...  | ...  | ...  | ...   | 40     | A1011     |
| 19.3  | 19.3 | 18.4 | 17.8 | 15.6 | ...  | ...  | ...  | ...  | ...  | ...   | ...    | A36       |
| 20.0  | 20.0 | 20.0 | 20.0 | 16.9 | 13.9 | ...  | ...  | ...  | ...  | ...   | 45     | A1011     |
| 21.7  | 21.7 | 21.7 | 20.5 | 16.9 | 13.9 | ...  | ...  | ...  | ...  | ...   | 50     | A1011     |
| <b>Carbon Steel — Forgings and Fittings [Note (5)]</b>              |      |      |      |      |      |      |      |      |      |       |        |           |
| 17.1  | 16.3 | 15.3 | 14.8 | 14.3 | 13.8 | 11.4 | 8.7  | 5.9  | 4.0  | 2.5   | LF1    | A350      |
| 17.1  | 16.3 | 15.3 | 14.8 | 14.3 | 13.8 | 11.4 | 8.7  | 5.9  | 4.0  | 2.5   | Cl. 60 | A181      |
| 19.9  | 19.0 | 17.9 | 17.3 | 16.7 | 13.9 | 11.4 | 8.7  | 5.9  | 4.0  | 2.5   | WPL6   | A420      |
| 19.9  | 19.0 | 17.9 | 17.3 | 16.7 | 13.9 | 11.4 | 8.7  | 5.9  | 4.0  | 2.5   | WPB    | A234      |
| 20.6  | 19.4 | 17.8 | 17.4 | 17.3 | 14.8 | 12.0 | 7.8  | 5.0  | 3.0  | 4.5   | LF2    | A350      |
| 20.5  | 19.6 | 18.4 | 17.8 | 17.2 | 14.8 | 12.0 | 9.3  | 6.7  | 4.0  | 2.5   | ...    | A105      |
| 20.5  | 19.6 | 18.4 | 17.8 | 17.2 | 14.8 | 12.0 | 9.3  | 6.7  | 4.0  | 2.5   | Cl. 70 | A181      |
| 22.8  | 21.7 | 20.4 | 19.8 | 18.3 | 14.8 | 12.0 | ...  | ...  | ...  | ...   | WPC    | A234      |
| <b>Carbon Steel — Castings [Note (5)]</b>                           |      |      |      |      |      |      |      |      |      |       |        |           |
| 17.1  | 16.3 | 15.3 | 14.8 | 14.3 | 13.8 | 11.4 | 8.7  | 5.9  | 4.0  | 2.5   | WCA    | A216      |
| 19.9  | 19.0 | 17.9 | 17.3 | 16.7 | 13.9 | 11.4 | 9.0  | 6.3  | 4.0  | 2.5   | LCB    | A352      |
| 20.5  | 19.6 | 18.4 | 17.8 | 17.2 | 14.8 | 12.0 | 9.3  | 6.7  | 4.0  | 2.5   | WCB    | A216      |
| 22.8  | 21.7 | 20.4 | 19.8 | 18.3 | 14.8 | 12.0 | 9.3  | 6.7  | 4.0  | 2.5   | WCC    | A216      |
| <b>Low and Intermediate Alloy Steel Pipes [Note (5)]</b>            |      |      |      |      |      |      |      |      |      |       |        |           |
| 16.9  | 16.3 | 15.7 | 15.4 | 15.1 | 13.8 | 13.5 | 13.2 | 12.8 | 9.2  | 5.9   | P2     | A335      |
| 18.3  | 17.9 | 17.3 | 16.9 | 16.6 | 13.8 | 13.8 | 13.4 | 12.8 | 9.2  | 5.9   | ½CR    | A691      |
| 16.9  | 16.3 | 15.7 | 15.4 | 15.1 | 13.8 | 13.5 | 13.2 | 12.7 | 8.2  | 4.8   | P1     | A335      |
| 16.9  | 16.3 | 15.7 | 15.4 | 15.1 | 13.8 | 13.5 | 13.2 | 12.7 | 8.2  | 4.8   | FP1    | A369      |
| 16.9  | 16.3 | 15.7 | 15.4 | 15.1 | 13.8 | 13.5 | 13.2 | 12.8 | 9.2  | 5.9   | FP2    | A369      |
| 18.3  | 17.9 | 17.3 | 16.9 | 16.6 | 16.3 | 15.9 | 15.4 | 14.0 | 11.3 | 7.2   | 1CR    | A691      |
| 16.3  | 15.6 | 14.9 | 14.6 | 14.2 | 13.9 | 13.5 | 13.2 | 12.5 | 10.0 | 6.3   | CP2    | A426      |

**Table IX-1A**  
**Basic Allowable Stresses in Tension for Metal Piping Materials (Cont'd)**

Specifications Are ASTM Unless Otherwise Indicated

| Material   | Spec. No. | P-No.<br>[Note (1)] | Grade | Notes               | Min.<br>Temp., °F<br>[Note (2)] | Specified Min.<br>Strength, ksi |       | Basic Allowable<br>Stress, S, ksi<br>[Note (3)], at Metal<br>Temperature, °F |      |      |
|--|-----------|---------------------|-------|---------------------|---------------------------------|---------------------------------|-------|--|------|------|
|  |           |                     |       |                     |                                 | Tensile                         | Yield | Min.<br>Temp.<br>to 100  | 200  | 300  |
| <b>Low and Intermediate Alloy Steel Pipes [Note (5)]</b> |           |                     |       |                     |                                 |                                 |       |  |      |      |
| 1½Si-½Mo   | A335      | 3                   | P15   | ...                 | -20                             | 60                              | 30    | 18.8   | 18.2 | 17.6 |
| 1½Si-½Mo   | A426      | 3                   | CP15  | (12)                | -20                             | 60                              | 30    | 18.8   | 18.2 | 17.6 |
| 1Cr-½Mo  | A426      | 4                   | CP12  | (12)                | -20                             | 60                              | 30    | 18.8   | 18.3 | 17.6 |
| 5Cr-½Mo-1½Si   | A426      | 5B                  | CP5b  | (12)                | -20                             | 60                              | 30    | 18.8   | 17.9 | 17.1 |
| 3Cr-Mo   | A426      | 5A                  | CP21  | (12)                | -20                             | 60                              | 30    | 18.8   | 18.1 | 17.4 |
| 2Cr-½Mo  | A369      | 4                   | FP3b  | ...                 | -20                             | 60                              | 30    | 20.0   | 18.5 | 17.5 |
| 1Cr-½Mo  | A335      | 4                   | P12   | ...                 | -20                             | 60                              | 32    | 20.0   | 18.7 | 18.0 |
| 1Cr-½Mo  | A369      | 4                   | FP12  | ...                 | -20                             | 60                              | 32    | 20.0   | 18.7 | 18.0 |
| 1¼Cr-½Mo   | A335      | 4                   | P11   | ...                 | -20                             | 60                              | 30    | 20.0   | 18.7 | 18.0 |
| 1¼Cr-½Mo   | A369      | 4                   | FP11  | ...                 | -20                             | 60                              | 30    | 20.0   | 18.7 | 18.0 |
| 1¼Cr-½Mo A387 Gr. 11 Cl. 1                               | A691      | 4                   | 1¼CR  | (13) (44)           | -20                             | 60                              | 35    | 20.0   | 20.0 | 20.0 |
| 5Cr-½Mo A387 Gr. 5 Cl. 1                                 | A691      | 5B                  | 5CR   | (13) (44)           | -20                             | 60                              | 30    | 20.0   | 18.1 | 17.4 |
| 5Cr-½Mo  | A335      | 5B                  | P5    | ...                 | -20                             | 60                              | 30    | 20.0   | 18.1 | 17.4 |
| 5Cr-½Mo-Si   | A335      | 5B                  | P5b   | ...                 | -20                             | 60                              | 30    | 20.0   | 18.1 | 17.4 |
| 5Cr-½Mo-Ti   | A335      | 5B                  | P5c   | ...                 | -20                             | 60                              | 30    | 20.0   | 18.1 | 17.4 |
| 5Cr-½Mo  | A369      | 5B                  | FP5   | ...                 | -20                             | 60                              | 30    | 20.0   | 18.1 | 17.4 |
| 9Cr-1Mo  | A335      | 5B                  | P9    | ...                 | -20                             | 60                              | 30    | 20.0   | 18.1 | 17.4 |
| 9Cr-1Mo  | A369      | 5B                  | FP9   | ...                 | -20                             | 60                              | 30    | 20.0   | 18.1 | 17.4 |
| 9Cr-1Mo A387 Gr. 9 Cl. 1                                 | A691      | 5B                  | 9CR   | ...                 | -20                             | 60                              | 30    | 20.0   | 18.1 | 17.4 |
| 3Cr-1Mo  | A335      | 5A                  | P21   | ...                 | -20                             | 60                              | 30    | 20.0   | 18.7 | 18.0 |
| 3Cr-1Mo  | A369      | 5A                  | FP21  | ...                 | -20                             | 60                              | 30    | 20.0   | 18.7 | 18.0 |
| 3Cr-1Mo A387 Gr. 21 Cl. 1                                | A691      | 5A                  | 3CR   | (13) (44)           | -20                             | 60                              | 30    | 20.0   | 18.5 | 18.1 |
| 2¼Cr-1Mo A387 Gr. 22 Cl. 1                               | A691      | 5A                  | 2¼CR  | (13) (44) (48) (49) | -20                             | 60                              | 30    | 20.0   | 18.5 | 18.0 |
| 2¼Cr-1Mo   | A369      | 5A                  | FP22  | (48) (49)           | -20                             | 60                              | 30    | 20.0   | 18.5 | 18.0 |
| 2¼Cr-1Mo   | A335      | 5A                  | P22   | (48) (49)           | -20                             | 60                              | 30    | 20.0   | 18.5 | 18.0 |
| C-½Mo  | A426      | 3                   | CP1   | (12) (39)           | -20                             | 65                              | 35    | 21.7   | 21.7 | 21.7 |
| C-Mo A204 Gr. A  | A672      | 3                   | L65   | (13) (39) (44)      | -20                             | 65                              | 37    | 21.7   | 21.7 | 21.7 |
| C-Mo A204 Gr. A  | A691      | 3                   | CM65  | (13) (39) (44)      | -20                             | 65                              | 37    | 21.7   | 21.7 | 21.7 |
| 3½Ni A203 Gr. E  | A671      | 9B                  | CF71  | (13) (39) (44)      | -20                             | 70                              | 40    | 23.3   | ...  | ...  |
| C-Mo A204 Gr. B  | A672      | 3                   | L70   | (13) (39) (44)      | -20                             | 70                              | 40    | 23.3   | 23.3 | 23.3 |
| C-Mo A204 Gr. B  | A691      | 3                   | CM70  | (13) (39) (44)      | -20                             | 70                              | 40    | 23.3   | 23.3 | 23.3 |
| 1¼Cr-½Mo   | A426      | 4                   | CP11  | (12)                | -20                             | 70                              | 40    | 23.3   | 23.3 | 23.3 |
| 2¼Cr-1Mo   | A426      | 5A                  | CP22  | (12) (48)           | -20                             | 70                              | 40    | 23.3   | 23.3 | 23.3 |



**Table IX-1A**  
**Basic Allowable Stresses in Tension for Metal Piping Materials (Cont'd)**  
 Specifications Are ASTM Unless Otherwise Indicated

| Basic Allowable Stress, S, ksi [Note (3)], at Metal Temperature, °F |      |      |      |      |      |      |      |      |      |       |       |           |
|---|------|------|------|------|------|------|------|------|------|-------|-------|-----------|
| 400   | 500  | 600  | 650  | 700  | 750  | 800  | 850  | 900  | 950  | 1,000 | Grade | Spec. No. |
| <b>Low and Intermediate Alloy Steel Pipes [Note (5)] (Cont'd)</b>   |      |      |      |      |      |      |      |      |      |       |       |           |
| 17.0  | 16.5 | 15.9 | 15.6 | 15.3 | 15.0 | 14.4 | 13.8 | 12.5 | 10.0 | 6.3   | P15   | A335      |
| 17.0  | 16.5 | 15.9 | 15.6 | 15.3 | 15.0 | 14.4 | 13.8 | 12.5 | 10.0 | 6.3   | CP15  | A426      |
| 17.1  | 16.5 | 15.9 | 15.7 | 15.4 | 15.1 | 14.8 | 14.2 | 13.1 | 11.3 | 7.2   | CP12  | A426      |
| 16.2  | 15.4 | 14.5 | 14.1 | 13.7 | 13.3 | 12.8 | 12.4 | 10.9 | 9.0  | 5.5   | CP5b  | A426      |
| 16.8  | 16.1 | 15.5 | 15.2 | 14.8 | 14.5 | 13.9 | 13.2 | 12.0 | 9.0  | 7.0   | CP21  | A426      |
| 16.4  | 16.3 | 15.7 | 15.4 | 15.1 | 13.9 | 13.5 | 13.1 | 12.5 | 10.0 | 6.2   | FP3b  | A369      |
| 17.5  | 17.2 | 16.7 | 16.2 | 15.6 | 15.2 | 15.0 | 14.5 | 12.8 | 11.3 | 7.2   | P12   | A335      |
| 17.5  | 17.2 | 16.7 | 16.2 | 15.6 | 15.2 | 15.0 | 14.5 | 12.8 | 11.3 | 7.2   | FP12  | A369      |
| 17.5  | 17.2 | 16.7 | 16.2 | 15.6 | 15.2 | 15.0 | 14.5 | 12.8 | 9.3  | 6.3   | P11   | A335      |
| 17.5  | 17.2 | 16.7 | 16.2 | 15.6 | 15.2 | 15.0 | 14.5 | 12.8 | 9.3  | 6.3   | FP11  | A369      |
| 19.7  | 18.9 | 18.3 | 18.0 | 17.6 | 17.3 | 16.8 | 16.3 | 15.0 | 9.9  | 6.3   | 1¼CR  | A691      |
| 17.2  | 17.1 | 16.8 | 16.6 | 16.3 | 13.2 | 12.8 | 12.1 | 10.9 | 8.0  | 5.8   | 5CR   | A691      |
| 17.2  | 17.1 | 16.8 | 16.6 | 16.3 | 13.2 | 12.8 | 12.1 | 10.9 | 8.0  | 5.8   | P5    | A335      |
| 17.2  | 17.1 | 16.8 | 16.6 | 16.3 | 13.2 | 12.8 | 12.1 | 10.9 | 8.0  | 5.8   | P5b   | A335      |
| 17.2  | 17.1 | 16.8 | 16.6 | 16.3 | 13.2 | 12.8 | 12.1 | 10.9 | 8.0  | 5.8   | P5c   | A335      |
| 17.2  | 17.1 | 16.8 | 16.6 | 16.3 | 13.2 | 12.8 | 12.1 | 10.9 | 8.0  | 5.8   | FP5   | A369      |
| 17.2  | 17.1 | 16.8 | 16.6 | 16.3 | 13.2 | 12.8 | 12.1 | 11.4 | 10.6 | 7.4   | P9    | A335      |
| 17.2  | 17.1 | 16.8 | 16.6 | 16.3 | 13.2 | 12.8 | 12.1 | 11.4 | 10.6 | 7.4   | FP9   | A369      |
| 17.2  | 17.1 | 16.8 | 16.6 | 16.3 | 13.2 | 12.8 | 12.1 | 11.4 | 10.6 | 7.4   | 9CR   | A691      |
| 17.5  | 17.2 | 16.7 | 16.2 | 15.6 | 15.2 | 15.0 | 14.0 | 12.0 | 9.0  | 7.0   | P21   | A335      |
| 17.5  | 17.2 | 16.7 | 16.2 | 15.6 | 15.2 | 15.0 | 14.0 | 12.0 | 9.0  | 7.0   | FP21  | A369      |
| 17.9  | 17.9 | 17.9 | 17.9 | 17.9 | 17.9 | 17.8 | 14.0 | 12.0 | 9.0  | 7.0   | 3CR   | A691      |
| 17.9  | 17.9 | 17.9 | 17.9 | 17.9 | 17.9 | 17.8 | 14.5 | 12.8 | 10.8 | 7.8   | 2¼CR  | A691      |
| 17.9  | 17.9 | 17.9 | 17.9 | 17.9 | 17.9 | 17.8 | 14.5 | 12.8 | 10.8 | 7.8   | FP22  | A369      |
| 17.9  | 17.9 | 17.9 | 17.9 | 17.9 | 17.9 | 17.8 | 14.5 | 12.8 | 10.8 | 7.8   | P22   | A335      |
| 21.7  | 21.3 | 20.7 | 20.4 | 20.0 | 16.3 | 15.7 | 14.4 | 12.5 | 10.0 | 6.3   | CP1   | A426      |
| 20.7  | 20.0 | 19.3 | 19.0 | 18.6 | 16.3 | 15.8 | 15.3 | 13.7 | 8.2  | 4.8   | L65   | A672      |
| 20.7  | 20.0 | 19.3 | 19.0 | 18.6 | 16.3 | 15.8 | 15.3 | 13.7 | 8.2  | 4.8   | CM65  | A691      |
| ...   | ...  | ...  | ...  | ...  | ...  | ...  | ...  | ...  | ...  | ...   | CF71  | A671      |
| 22.5  | 21.7 | 20.9 | 20.5 | 20.1 | 17.5 | 17.5 | 17.1 | 13.7 | 8.2  | 4.8   | L70   | A672      |
| 22.5  | 21.7 | 20.9 | 20.5 | 20.1 | 17.5 | 17.5 | 17.1 | 13.7 | 8.2  | 4.8   | CM70  | A691      |
| 23.3  | 22.9 | 22.3 | 21.6 | 20.9 | 15.5 | 15.0 | 14.4 | 13.7 | 9.3  | 6.3   | CP11  | A426      |
| 23.3  | 22.9 | 22.3 | 21.6 | 20.9 | 17.5 | 17.5 | 16.0 | 14.0 | 11.0 | 7.8   | CP22  | A426      |

**Table IX-1A**  
**Basic Allowable Stresses in Tension for Metal Piping Materials (Cont'd)**

Specifications Are ASTM Unless Otherwise Indicated

| Material   | Spec. No. | P-No.<br>[Note (1)] | Grade      | Notes          | Min.<br>Temp., °F<br>[Note (2)] | Specified Min.<br>Strength, ksi |       | Basic Allowable<br>Stress, S, ksi<br>[Note (3)], at Metal<br>Temperature, °F |      |      |
|--|-----------|---------------------|------------|----------------|---------------------------------|---------------------------------|-------|--|------|------|
|  |           |                     |            |                |                                 | Tensile                         | Yield | Min.<br>Temp.<br>to 100  | 200  | 300  |
| <b>Low and Intermediate Alloy Steel Pipes [Note (5)]</b>                 |           |                     |            |                |                                 |                                 |       |  |      |      |
| C-Mo A204 Gr. C  | A672      | 3                   | L75        | (13) (39) (44) | -20                             | 75                              | 43    | 25.0   | 25.0 | 25.0 |
| C-Mo A204 Gr. C  | A691      | 3                   | CM75       | (13) (39) (44) | -20                             | 75                              | 43    | 25.0   | 25.0 | 25.0 |
| <b>Low and Intermediate Alloy Steel Plates</b>                           |           |                     |            |                |                                 |                                 |       |  |      |      |
| ½Cr-½Mo  | A387      | 3                   | 2 Cl. 1    | ...            | -20                             | 55                              | 33    | 18.3   | 18.3 | 18.3 |
| 1Cr-½Mo  | A387      | 4                   | 12 Cl. 1   | ...            | -20                             | 55                              | 33    | 18.3   | 18.3 | 18.3 |
| 1¼Cr-½Mo   | A387      | 4                   | 11 Cl. 1   | ...            | -20                             | 60                              | 35    | 20.0   | 20.0 | 20.0 |
| 5Cr-½Mo  | A387      | 5B                  | 5 Cl. 1    | ...            | -20                             | 60                              | 30    | 20.0   | 18.1 | 17.4 |
| 3Cr-1Mo  | A387      | 5A                  | 21 Cl. 1   | ...            | -20                             | 60                              | 30    | 20.0   | 18.5 | 18.1 |
| 2¼Cr-1Mo   | A387      | 5A                  | 22 Cl. 1   | (48)           | -20                             | 60                              | 30    | 20.0   | 18.5 | 18.0 |
| C-½Mo  | A204      | 3                   | A          | (39)           | -20                             | 65                              | 37    | 21.7   | 21.7 | 21.7 |
| 1Cr-½Mo  | A387      | 4                   | 12 Cl. 2   | ...            | -20                             | 65                              | 40    | 21.7   | 21.7 | 21.7 |
| ½Cr-½Mo  | A387      | 3                   | 2 Cl. 2    | ...            | -20                             | 70                              | 45    | 23.3   | 17.5 | 17.5 |
| C-½Mo  | A204      | 3                   | B          | (39)           | -20                             | 70                              | 40    | 23.3   | 23.3 | 23.3 |
| Cr-Mn-Si   | A202      | 4                   | A          | ...            | -20                             | 75                              | 45    | 25.0   | 23.9 | 22.8 |
| Mn-Mo  | A302      | 3                   | A          | ...            | -20                             | 75                              | 45    | 25.0   | 25.0 | 25.0 |
| C-½Mo  | A204      | 3                   | C          | (39)           | -20                             | 75                              | 43    | 25.0   | 25.0 | 25.0 |
| 1¼Cr-½Mo   | A387      | 4                   | 11 Cl. 2   | ...            | -20                             | 75                              | 45    | 25.0   | 25.0 | 25.0 |
| 5Cr-½Mo  | A387      | 5B                  | 5 Cl. 2    | ...            | -20                             | 75                              | 45    | 25.0   | 24.9 | 24.2 |
| 3Cr-½Mo  | A387      | 5A                  | 21 Cl. 2   | ...            | -20                             | 75                              | 45    | 25.0   | 25.0 | 24.5 |
| 2¼Cr-1Mo   | A387      | 5A                  | 22 Cl. 2   | (48)           | -20                             | 75                              | 45    | 25.0   | 25.0 | 24.5 |
| Mn-Mo  | A302      | 3                   | B          | ...            | -20                             | 80                              | 50    | 26.7   | 26.7 | 26.7 |
| Mn-Mo-Ni   | A302      | 3                   | C          | ...            | -20                             | 80                              | 50    | 26.7   | 26.7 | 26.7 |
| Mn-Mo-Ni   | A302      | 3                   | D          | ...            | -20                             | 80                              | 50    | 26.7   | 26.7 | 26.7 |
| Cr-Mn-Si   | A202      | 4                   | B          | ...            | -20                             | 85                              | 47    | 28.4   | 27.1 | 25.8 |
| <b>Low and Intermediate Alloy Steel Forgings and Fittings [Note (5)]</b> |           |                     |            |                |                                 |                                 |       |  |      |      |
| C-½Mo  | A234      | 3                   | WP1        | (39)           | -20                             | 55                              | 30    | 18.3   | 18.3 | 17.5 |
| 1Cr-½Mo  | A182      | 4                   | F12 Cl. 1  | (11)           | -20                             | 60                              | 32    | 20.0   | 19.3 | 18.1 |
| 1Cr-½Mo  | A234      | 4                   | WP12 Cl. 1 | ...            | -20                             | 60                              | 32    | 20.0   | 19.3 | 18.1 |
| 1¼Cr-½Mo   | A182      | 4                   | F11 Cl. 1  | (11)           | -20                             | 60                              | 30    | 20.0   | 18.7 | 18.0 |
| 1¼Cr-½Mo   | A234      | 4                   | WP11 Cl. 1 | ...            | -20                             | 60                              | 30    | 20.0   | 18.7 | 18.0 |
| 2¼Cr-1Mo   | A182      | ...                 | F22 Cl. 1  | (11) (48) (49) | -20                             | 60                              | 30    | 20.0   | 18.5 | 18.0 |
| 2¼Cr-1Mo   | A234      | 5A                  | WP22 Cl. 1 | (48)           | -20                             | 60                              | 30    | 20.0   | 18.5 | 18.0 |
| ½Cr-½Mo  | A182      | 3                   | F2         | (11)           | -20                             | 70                              | 40    | 23.3   | 23.3 | 23.3 |
| C-½Mo  | A182      | 3                   | F1         | (11) (39)      | -20                             | 70                              | 40    | 23.3   | 23.3 | 23.3 |

**Table IX-1A**  
**Basic Allowable Stresses in Tension for Metal Piping Materials (Cont'd)**

Specifications Are ASTM Unless Otherwise Indicated

| Basic Allowable Stress, S, ksi [Note (3)], at Metal Temperature, °F      |      |      |      |      |      |      |      |      |      |       |            |           |
|--|------|------|------|------|------|------|------|------|------|-------|------------|-----------|
| 400  | 500  | 600  | 650  | 700  | 750  | 800  | 850  | 900  | 950  | 1,000 | Grade      | Spec. No. |
| <b>Low and Intermediate Alloy Steel Pipes [Note (5)] (Cont'd)</b>        |      |      |      |      |      |      |      |      |      |       |            |           |
| 24.1   | 23.3 | 22.5 | 22.1 | 21.7 | 18.8 | 18.8 | 18.3 | 13.7 | 8.2  | 4.8   | L75        | A672      |
| 24.1   | 23.3 | 22.5 | 22.1 | 21.7 | 18.8 | 18.8 | 18.3 | 13.7 | 8.2  | 4.8   | CM75       | A691      |
| <b>Low and Intermediate Alloy Steel Plates</b>                           |      |      |      |      |      |      |      |      |      |       |            |           |
| 18.3   | 17.9 | 17.3 | 16.9 | 16.6 | 13.8 | 13.8 | 13.4 | 12.8 | 9.2  | 5.9   | 2 Cl. 1    | A387      |
| 18.3   | 17.9 | 17.3 | 16.9 | 16.6 | 16.3 | 15.9 | 15.4 | 14.0 | 11.3 | 7.2   | 12 Cl. 1   | A387      |
| 19.7   | 18.9 | 18.3 | 18.0 | 17.6 | 17.3 | 16.8 | 16.3 | 13.7 | 9.3  | 6.3   | 11 Cl. 1   | A387      |
| 17.2   | 17.1 | 16.8 | 16.6 | 16.3 | 13.2 | 12.8 | 12.1 | 10.9 | 8.0  | 5.8   | 5 Cl. 1    | A387      |
| 17.9   | 17.9 | 17.9 | 17.9 | 17.9 | 17.9 | 17.8 | 14.0 | 12.0 | 9.0  | 7.0   | 21 Cl. 1   | A387      |
| 17.9   | 17.9 | 17.9 | 17.9 | 17.9 | 17.9 | 17.8 | 14.5 | 12.8 | 10.8 | 8.0   | 22 Cl. 1   | A387      |
| 20.7   | 20.0 | 19.3 | 19.0 | 18.6 | 16.3 | 15.8 | 15.3 | 13.7 | 8.2  | 4.8   | A          | A204      |
| 21.7   | 21.7 | 20.9 | 20.5 | 20.1 | 19.7 | 19.2 | 18.7 | 18.0 | 11.3 | 7.2   | 12 Cl. 2   | A387      |
| 17.5   | 17.5 | 17.5 | 17.5 | 17.5 | 17.5 | 17.5 | 16.8 | 14.5 | 10.0 | 6.3   | 2 Cl. 2    | A387      |
| 22.5   | 21.7 | 20.9 | 20.5 | 20.1 | 17.5 | 17.5 | 17.1 | 13.7 | 8.2  | 4.8   | B          | A204      |
| 21.6   | 20.5 | 19.3 | 18.8 | 17.7 | 15.7 | 12.0 | 7.8  | 5.0  | 3.0  | 1.5   | A          | A202      |
| 25.0   | 25.0 | 25.0 | 25.0 | 25.0 | 18.3 | 17.7 | 16.8 | 13.7 | 8.2  | 4.8   | A          | A302      |
| 24.1   | 23.3 | 22.5 | 22.1 | 21.7 | 18.8 | 18.8 | 18.3 | 13.7 | 8.2  | 4.8   | C          | A204      |
| 25.0   | 24.3 | 23.5 | 23.1 | 22.7 | 22.2 | 21.6 | 21.1 | 13.7 | 9.3  | 6.3   | 11 Cl. 2   | A387      |
| 24.1   | 23.9 | 23.6 | 23.2 | 22.8 | 16.5 | 16.0 | 15.1 | 10.9 | 8.0  | 5.8   | 5 Cl. 2    | A387      |
| 24.1   | 23.9 | 23.8 | 23.6 | 23.4 | 23.0 | 22.5 | 19.0 | 13.1 | 9.5  | 6.8   | 21 Cl. 2   | A387      |
| 24.1   | 23.9 | 23.8 | 23.6 | 23.4 | 23.0 | 22.5 | 21.8 | 17.0 | 11.4 | 7.8   | 22 Cl. 2   | A387      |
| 26.7   | 26.7 | 26.7 | 26.7 | 26.7 | 19.6 | 18.8 | 17.9 | 13.7 | 8.2  | 4.8   | B          | A302      |
| 26.7   | 26.7 | 26.7 | 26.7 | 26.7 | 19.6 | 18.8 | 17.9 | 13.7 | 8.2  | 4.8   | C          | A302      |
| 26.7   | 26.7 | 26.7 | 26.7 | 26.7 | 19.6 | 18.8 | 17.9 | 13.7 | 8.2  | 4.8   | D          | A302      |
| 24.5   | 23.2 | 21.9 | 21.3 | 19.8 | 17.7 | 12.0 | 7.8  | 5.0  | 3.0  | 1.5   | B          | A202      |
| <b>Low and Intermediate Alloy Steel Forgings and Fittings [Note (5)]</b> |      |      |      |      |      |      |      |      |      |       |            |           |
| 16.9   | 16.3 | 15.7 | 15.4 | 15.1 | 13.8 | 13.5 | 13.2 | 12.7 | 8.2  | 4.8   | WP1        | A234      |
| 17.3   | 16.7 | 16.3 | 16.0 | 15.8 | 15.5 | 15.3 | 14.9 | 14.5 | 11.3 | 7.2   | F12 Cl. 1  | A182      |
| 17.3   | 16.7 | 16.3 | 16.0 | 15.8 | 15.5 | 15.3 | 14.9 | 14.5 | 11.3 | 7.2   | WP12 Cl. 1 | A234      |
| 17.5   | 17.2 | 16.7 | 16.2 | 15.6 | 15.2 | 15.0 | 14.5 | 12.8 | 9.3  | 6.3   | F11 Cl. 1  | A182      |
| 17.5   | 17.2 | 16.7 | 16.2 | 15.6 | 15.2 | 15.0 | 14.5 | 12.8 | 9.3  | 6.3   | WP11 Cl. 1 | A234      |
| 17.9   | 17.9 | 17.9 | 17.9 | 17.9 | 17.9 | 17.8 | 14.5 | 12.8 | 10.8 | 7.8   | F22 Cl. 1  | A182      |
| 17.9   | 17.9 | 17.9 | 17.9 | 17.9 | 17.9 | 17.8 | 14.5 | 12.8 | 10.8 | 7.8   | WP22 Cl. 1 | A234      |
| 22.5   | 21.7 | 20.9 | 20.5 | 20.1 | 17.5 | 17.5 | 17.1 | 15.0 | 9.2  | 5.9   | F2         | A182      |
| 22.5   | 21.7 | 20.9 | 20.5 | 20.1 | 17.5 | 17.5 | 17.1 | 13.7 | 8.2  | 4.8   | F1         | A182      |

**Table IX-1A**  
**Basic Allowable Stresses in Tension for Metal Piping Materials (Cont'd)**

Specifications Are ASTM Unless Otherwise Indicated

| Material   | Spec. No. | P-No.<br>[Note (1)] | Grade                          | Notes | Min.<br>Temp., °F<br>[Note (2)] | Specified Min.<br>Strength, ksi |       | Basic Allowable<br>Stress, S, ksi<br>[Note (3)], at Metal<br>Temperature, °F |      |      |
|--|-----------|---------------------|--------------------------------|-------|---------------------------------|---------------------------------|-------|--|------|------|
|  |           |                     |                                |       |                                 | Tensile                         | Yield | Min.<br>Temp.<br>to 100  | 200  | 300  |
| <b>Low and Intermediate Alloy Steel Forgings and Fittings [Note (5)]</b> |           |                     |                                |       |                                 |                                 |       |  |      |      |
| 1Cr- $\frac{1}{2}$ Mo  | A182      | 4                   | F12 Cl. 2 (11)                 |       | -20                             | 70                              | 40    | 23.3   | 23.3 | 23.3 |
| 1Cr- $\frac{1}{2}$ Mo  | A234      | 4                   | WP12 Cl. 2 ...                 |       | -20                             | 70                              | 40    | 23.3   | 23.3 | 23.3 |
| $1\frac{1}{4}$ Cr- $\frac{1}{2}$ Mo                                      | A182      | 4                   | F11 Cl. 2 (11)                 |       | -20                             | 70                              | 40    | 23.3   | 23.3 | 23.3 |
| $1\frac{1}{4}$ Cr- $\frac{1}{2}$ Mo                                      | A234      | 4                   | WP11 Cl. 2 ...                 |       | -20                             | 70                              | 40    | 23.3   | 23.3 | 23.3 |
| $2\frac{1}{4}$ Cr-1Mo  | A182      | 5A                  | F22 Cl. 3 (11) (48)            |       | -20                             | 75                              | 45    | 25.0   | 25.0 | 24.5 |
| $2\frac{1}{4}$ Cr-1Mo  | A234      | 5A                  | WP22 Cl. 3 (48)                |       | -20                             | 75                              | 45    | 25.0   | 25.0 | 24.5 |
| <b>Low and Intermediate Alloy Steel Castings [Note (5)]</b>              |           |                     |                                |       |                                 |                                 |       |  |      |      |
| C- $\frac{1}{2}$ Mo  | A352      | 3                   | LC1 (11) (39)                  |       | -75                             | 65                              | 35    | 21.7   | 21.5 | 20.5 |
| C- $\frac{1}{2}$ Mo  | A217      | 3                   | WC1 (11) (39)                  |       | -20                             | 65                              | 35    | 21.7   | 21.5 | 20.5 |
| $1\frac{1}{4}$ Cr- $\frac{1}{2}$ Mo                                      | A217      | 4                   | WC6 (11)                       |       | -20                             | 70                              | 40    | 23.3   | 23.3 | 23.3 |
| $2\frac{1}{4}$ Cr-1Mo  | A217      | 5A                  | WC9 (11)                       |       | -20                             | 70                              | 40    | 23.3   | 23.3 | 23.1 |
| <b>Stainless Steel [Notes (6), (7)] — Pipes and Tubes [Note (5)]</b>     |           |                     |                                |       |                                 |                                 |       |  |      |      |
| 18Cr-8Ni tube  | A213      | 8                   | TP304L (15) (30)               |       | -425                            | 70                              | 25    | 16.7   | 16.7 | 16.7 |
| 18Cr-8Ni tube  | A249      | 8                   | TP304L (15) (30)               |       | -425                            | 70                              | 25    | 16.7   | 16.7 | 16.7 |
| 18Cr-8Ni tube  | A269      | 8                   | TP304L (15) (30)               |       | -425                            | 70                              | 25    | 16.7   | 16.7 | 16.7 |
| 18Cr-8Ni pipe  | A312      | 8                   | TP304L ...                     |       | -425                            | 70                              | 25    | 16.7   | 16.7 | 16.7 |
| Type 304L A240   | A358      | 8                   | 304L (30) (54)                 |       | -425                            | 70                              | 25    | 16.7   | 16.7 | 16.7 |
| 16Cr-12Ni-2Mo tube   | A213      | 8                   | TP316L (15) (30)               |       | -425                            | 70                              | 25    | 16.7   | 16.7 | 16.7 |
| 16Cr-12Ni-2Mo tube   | A249      | 8                   | TP316L (15) (30)               |       | -425                            | 70                              | 25    | 16.7   | 16.7 | 16.7 |
| 16Cr-12Ni-2Mo tube   | A269      | 8                   | TP316L (15) (30)               |       | -425                            | 70                              | 25    | 16.7   | 16.7 | 16.7 |
| 16Cr-12Ni-2Mo pipe   | A312      | 8                   | TP316L ...                     |       | -425                            | 70                              | 25    | 16.7   | 16.7 | 16.7 |
| Type 316L A240   | A358      | 8                   | 316L (30) (54)                 |       | -425                            | 70                              | 25    | 16.7   | 16.7 | 16.7 |
| 18Cr-8Ni   | A451      | 8                   | CPF8 (22) (24)                 |       | -425                            | 70                              | 30    | 20.0   | 20.0 | 20.0 |
| 18Cr-10Ni-Cb pipe  | A312      | 8                   | TP347 ...                      |       | -425                            | 75                              | 30    | 20.0   | 20.0 | 20.0 |
| Type 347 A240  | A358      | 8                   | 347 (25) (30)                  |       | -425                            | 75                              | 30    | 20.0   | 20.0 | 20.0 |
| 18Cr-10Ni-Cb pipe  | A376      | 8                   | TP347 (25) (30)                |       | -425                            | 75                              | 30    | 20.0   | 20.0 | 20.0 |
| 18Cr-10Ni-Cb pipe  | A409      | 8                   | TP347 (25) (30)                |       | -425                            | 75                              | 30    | 20.0   | 20.0 | 20.0 |
| 16Cr-12Ni-Mo tube  | A213      | 8                   | TP316 (15) (22) (24) (26) (30) |       | -425                            | 75                              | 30    | 20.0   | 20.0 | 20.0 |
| 16Cr-12Ni-Mo tube  | A249      | 8                   | TP316 (15) (22) (24) (26) (30) |       | -425                            | 75                              | 30    | 20.0   | 20.0 | 20.0 |
| 16Cr-12Ni-Mo tube  | A269      | 8                   | TP316 (15) (22) (24) (26) (30) |       | -425                            | 75                              | 30    | 20.0   | 20.0 | 20.0 |
| 16Cr-12Ni-2Mo pipe   | A312      | 8                   | TP316 (22) (24)                |       | -425                            | 75                              | 30    | 20.0   | 20.0 | 20.0 |
| Type 316 A240  | A358      | 8                   | 316 (22) (24) (26) (30)        |       | -425                            | 75                              | 30    | 20.0   | 20.0 | 20.0 |
| 16Cr-12Ni-2Mo pipe   | A376      | 8                   | TP316 (22) (24) (26) (30)      |       | -425                            | 75                              | 30    | 20.0   | 20.0 | 20.0 |
| 16Cr-12Ni-2Mo pipe   | A409      | 8                   | TP316 (22) (24) (26) (30)      |       | -425                            | 75                              | 30    | 20.0   | 20.0 | 20.0 |
| 16Cr-12Ni-2Mo pipe   | A312      | 8                   | TP316H (22)                    |       | -325                            | 75                              | 30    | 20.0   | 20.0 | 20.0 |

**Table IX-1A**  
**Basic Allowable Stresses in Tension for Metal Piping Materials (Cont'd)**  
 Specifications Are ASTM Unless Otherwise Indicated

| Basic Allowable Stress, S, ksi [Note (3)], at Metal Temperature, °F               |      |      |      |      |      |      |      |      |      |       |            |           |
|---|------|------|------|------|------|------|------|------|------|-------|------------|-----------|
| 400   | 500  | 600  | 650  | 700  | 750  | 800  | 850  | 900  | 950  | 1,000 | Grade      | Spec. No. |
| <b>Low and Intermediate Alloy Steel Forgings and Fittings [Note (5)] (Cont'd)</b> |      |      |      |      |      |      |      |      |      |       |            |           |
| 22.5  | 21.7 | 20.9 | 20.5 | 20.1 | 19.7 | 19.2 | 18.7 | 18.0 | 11.3 | 7.2   | F12 Cl. 2  | A182      |
| 22.5  | 21.7 | 20.9 | 20.5 | 20.1 | 19.7 | 19.2 | 18.7 | 18.0 | 11.3 | 7.2   | WP12 Cl. 2 | A234      |
| 22.5  | 21.7 | 20.9 | 20.5 | 20.1 | 19.7 | 19.2 | 18.7 | 13.7 | 9.3  | 6.3   | F11 Cl. 2  | A182      |
| 22.5  | 21.7 | 20.9 | 20.5 | 20.1 | 19.7 | 19.2 | 18.7 | 13.7 | 9.3  | 6.3   | WP11 Cl. 2 | A234      |
| 24.1  | 23.9 | 23.8 | 23.6 | 23.4 | 23.0 | 22.5 | 21.8 | 17.0 | 11.4 | 7.8   | F22 Cl. 3  | A182      |
| 24.1  | 23.9 | 23.8 | 23.6 | 23.4 | 23.0 | 22.5 | 21.8 | 17.0 | 11.4 | 7.8   | WP22 Cl. 3 | A234      |
| <b>Low and Intermediate Alloy Steel Castings [Note (5)]</b>                       |      |      |      |      |      |      |      |      |      |       |            |           |
| 19.7  | 18.9 | 18.3 | 18.0 | 17.6 | ...  | ...  | ...  | ...  | ...  | ...   | LC1        | A352      |
| 19.7  | 18.9 | 18.3 | 18.0 | 17.6 | 16.2 | 15.8 | 15.3 | 13.7 | 8.2  | 4.8   | WC1        | A217      |
| 22.5  | 21.7 | 20.9 | 20.5 | 20.1 | 19.7 | 19.2 | 18.7 | 14.5 | 11.0 | 6.9   | WC6        | A217      |
| 22.5  | 22.4 | 22.4 | 22.2 | 21.9 | 21.5 | 21.0 | 19.8 | 17.0 | 11.4 | 7.8   | WC9        | A217      |
| <b>Stainless Steel [Notes (6), (7)]— Pipes and Tubes [Note (5)]</b>               |      |      |      |      |      |      |      |      |      |       |            |           |
| 15.8  | 14.7 | 14.0 | 13.7 | 13.5 | 13.3 | 13.0 | 12.8 | 12.6 | 12.3 | 12.0  | TP304L     | A213      |
| 15.8  | 14.7 | 14.0 | 13.7 | 13.5 | 13.3 | 13.0 | 12.8 | 12.6 | 12.3 | 12.0  | TP304L     | A249      |
| 15.8  | 14.7 | 14.0 | 13.7 | 13.5 | 13.3 | 13.0 | 12.8 | 12.6 | 12.3 | 12.0  | TP304L     | A269      |
| 15.8  | 14.7 | 14.0 | 13.7 | 13.5 | 13.3 | 13.0 | 12.8 | 12.6 | 12.3 | 12.0  | TP304L     | A312      |
| 15.8  | 14.7 | 14.0 | 13.7 | 13.5 | 13.3 | 13.0 | 12.8 | 12.6 | 12.3 | 12.0  | 304L       | A358      |
| 15.7  | 14.8 | 40.0 | 13.7 | 13.5 | 13.2 | 12.9 | 12.7 | 12.4 | 12.1 | 11.8  | TP316L     | A213      |
| 15.7  | 14.8 | 40.0 | 13.7 | 13.5 | 13.2 | 12.9 | 12.7 | 12.4 | 12.1 | 11.8  | TP316L     | A249      |
| 15.7  | 14.8 | 40.0 | 13.7 | 13.5 | 13.2 | 12.9 | 12.7 | 12.4 | 12.1 | 11.8  | TP316L     | A269      |
| 15.7  | 14.8 | 40.0 | 13.7 | 13.5 | 13.2 | 12.9 | 12.7 | 12.4 | 12.1 | 11.8  | TP316L     | A312      |
| 15.7  | 14.8 | 40.0 | 13.7 | 13.5 | 13.2 | 12.9 | 12.7 | 12.4 | 12.1 | 11.8  | 316L       | A358      |
| 18.6  | 17.5 | 16.6 | 16.2 | 15.8 | 15.5 | 15.2 | 14.9 | 14.6 | 14.3 | 12.2  | CPF8       | A451      |
| 20.0  | 20.0 | 19.3 | 19.0 | 18.7 | 18.5 | 18.3 | 18.2 | 18.1 | 18.1 | 16.0  | TP347      | A312      |
| 20.0  | 20.0 | 19.3 | 19.0 | 18.7 | 18.5 | 18.3 | 18.2 | 18.1 | 18.1 | 16.0  | 347        | A358      |
| 20.0  | 20.0 | 19.3 | 19.0 | 18.7 | 18.5 | 18.3 | 18.2 | 18.1 | 18.1 | 16.0  | TP347      | A376      |
| 20.0  | 20.0 | 19.3 | 19.0 | 18.7 | 18.5 | 18.3 | 18.2 | 18.1 | 18.1 | 16.0  | TP347      | A409      |
| 19.3  | 18.0 | 17.0 | 16.6 | 16.3 | 16.1 | 15.9 | 15.7 | 15.5 | 15.4 | 15.3  | TP316      | A213      |
| 19.3  | 18.0 | 17.0 | 16.6 | 16.3 | 16.1 | 15.9 | 15.7 | 15.5 | 15.4 | 15.3  | TP316      | A249      |
| 19.3  | 18.0 | 17.0 | 16.6 | 16.3 | 16.1 | 15.9 | 15.7 | 15.5 | 15.4 | 15.3  | TP316      | A269      |
| 19.3  | 18.0 | 17.0 | 16.6 | 16.3 | 16.1 | 15.9 | 15.7 | 15.5 | 15.4 | 15.3  | TP316      | A312      |
| 19.3  | 18.0 | 17.0 | 16.6 | 16.3 | 16.1 | 15.9 | 15.7 | 15.5 | 15.4 | 15.3  | 316        | A358      |
| 19.3  | 18.0 | 17.0 | 16.6 | 16.3 | 16.1 | 15.9 | 15.7 | 15.5 | 15.4 | 15.3  | TP316      | A376      |
| 19.3  | 18.0 | 17.0 | 16.6 | 16.3 | 16.1 | 15.9 | 15.7 | 15.5 | 15.4 | 15.3  | TP316      | A409      |
| 19.3  | 18.0 | 17.0 | 16.6 | 16.3 | 16.1 | 15.9 | 15.7 | 15.5 | 15.4 | 15.3  | TP316H     | A312      |

**Table IX-1A**  
**Basic Allowable Stresses in Tension for Metal Piping Materials (Cont'd)**

Specifications Are ASTM Unless Otherwise Indicated

| Material   | Spec. No. | P-No.<br>[Note (1)] | Grade  | Notes                    | Min.<br>Temp., °F<br>[Note (2)] | Specified Min.<br>Strength, ksi |       | Basic Allowable<br>Stress, S, ksi<br>[Note (3)], at Metal<br>Temperature, °F |      |      |
|--|-----------|---------------------|--------|--------------------------|---------------------------------|---------------------------------|-------|--|------|------|
|  |           |                     |        |                          |                                 | Tensile                         | Yield | Min.<br>Temp.<br>to 100  | 200  | 300  |
| <b>Stainless Steel [Notes (6), (7)] — Pipes and Tubes [Note (5)]</b>       |           |                     |        |                          |                                 |                                 |       |  |      |      |
| 18Cr-10Ni-Cb pipe  | A376      | 8                   | TP347H | (25) (30)                | -325                            | 75                              | 30    | 20.0   | 20.0 | 20.0 |
| 18Cr-10Ni-Cb pipe  | A312      | 8                   | TP347  | (24)                     | -425                            | 75                              | 30    | 20.0   | 20.0 | 20.0 |
| Type 347 A240  | A358      | 8                   | 347    | (24) (25) (30)           | -425                            | 75                              | 30    | 20.0   | 20.0 | 20.0 |
| 18Cr-10Ni-Cb pipe  | A376      | 8                   | TP347  | (24) (25) (30)           | -425                            | 75                              | 30    | 20.0   | 20.0 | 20.0 |
| 18Cr-10Ni-Cb pipe  | A409      | 8                   | TP347  | (24) (25) (30)           | -425                            | 75                              | 30    | 20.0   | 20.0 | 20.0 |
| 18Cr-10Ni-Cb pipe  | A312      | 8                   | TP347H | (15) (22) (24) (26) (30) | -325                            | 75                              | 30    | 20.0   | 20.0 | 20.0 |
| 18Cr-8Ni tube  | A213      | 8                   | TP304  | ...                      | -425                            | 75                              | 30    | 20.0   | 20.0 | 20.0 |
| 18Cr-8Ni tube  | A249      | 8                   | TP304N | ...                      | -320                            | 75                              | 30    | 20.0   | 20.0 | 20.0 |
| 18Cr-8Ni tube  | A269      | 8                   | TP304  | (15) (22) (24) (26) (30) | -425                            | 75                              | 30    | 20.0   | 20.0 | 20.0 |
| 18Cr-8Ni pipe  | A312      | 8                   | TP304  | (22) (24)                | -425                            | 75                              | 30    | 20.0   | 20.0 | 20.0 |
| Type 304 A240  | A358      | 8                   | 304    | (22) (24) (26) (30)      | -425                            | 75                              | 30    | 20.0   | 20.0 | 20.0 |
| 18Cr-8Ni pipe  | A376      | 8                   | TP304  | (16) (22) (24) (26) (30) | -425                            | 75                              | 30    | 20.0   | 20.0 | 20.0 |
| 18Cr-8Ni pipe  | A376      | 8                   | TP304H | (22) (26) (30)           | -325                            | 75                              | 30    | 20.0   | 20.0 | 20.0 |
| 18Cr-8Ni pipe  | A409      | 8                   | TP304  | (22) (24) (26) (30)      | -425                            | 75                              | 30    | 20.0   | 20.0 | 20.0 |
| 18Cr-8Ni pipe  | A312      | 8                   | TP304H | (22)                     | -325                            | 75                              | 30    | 20.0   | 20.0 | 20.0 |
| 18Cr-10Ni-Mo   | A451      | 8                   | CPF8M  | (22) (24)                | -425                            | 70                              | 30    | 20.0   | 20.0 | 18.9 |
| <b>Stainless Steel [Notes (6), (7)] — Plates and Sheets</b>                |           |                     |        |                          |                                 |                                 |       |  |      |      |
| 18Cr-8Ni   | A240      | 8                   | 304L   | (30)                     | -425                            | 70                              | 25    | 16.7   | 16.7 | 16.7 |
| 16Cr-12Ni-2Mo  | A240      | 8                   | 316L   | (30)                     | -425                            | 70                              | 25    | 16.7   | 16.7 | 16.7 |
| 18Cr-10Ni-Cb   | A240      | 8                   | 347    | (30)                     | -425                            | 75                              | 30    | 20.0   | 20.0 | 20.0 |
| 16Cr-12Ni-2Mo  | A240      | 8                   | 316    | (24) (25) (30)           | -425                            | 75                              | 30    | 20.0   | 20.0 | 20.0 |
| 18Cr-10Ni-Cb   | A240      | 8                   | 347    | (24) (30)                | -425                            | 75                              | 30    | 20.0   | 20.0 | 20.0 |
| 18Cr-8Ni   | A240      | 8                   | 304    | (22) (24) (30)           | -425                            | 75                              | 30    | 20.0   | 20.0 | 20.0 |
| <b>Stainless Steel [Notes (6), (7)] — Forgings and Fittings [Note (5)]</b> |           |                     |        |                          |                                 |                                 |       |  |      |      |
| 18Cr-8Ni   | A182      | 8                   | F304L  | (11) (18)                | -425                            | 70                              | 25    | 16.7   | 16.7 | 16.7 |
| 18Cr-8Ni   | A403      | 8                   | WP304L | (27) (31)                | -425                            | 70                              | 25    | 16.7   | 16.7 | 16.7 |
| 16Cr-12Ni-2Mo  | A182      | 8                   | F316L  | (11) (18)                | -425                            | 70                              | 25    | 16.7   | 16.7 | 16.7 |
| 16Cr-12Ni-2Mo  | A403      | 8                   | WP316L | (27) (31)                | -425                            | 70                              | 25    | 16.7   | 16.7 | 16.7 |
| 18Cr-10Ni-Cb   | A182      | 8                   | F347   | (11) (17)                | -425                            | 75                              | 30    | 20.0   | 20.0 | 20.0 |
| 18Cr-10Ni-Cb   | A403      | 8                   | WP347  | (27) (31)                | -425                            | 75                              | 30    | 20.0   | 20.0 | 20.0 |
| 16Cr-12Ni-2Mo  | A403      | 8                   | WP316H | (22) (27) (31)           | -325                            | 75                              | 30    | 20.0   | 20.0 | 20.0 |
| 16Cr-12Ni-2Mo  | A182      | 8                   | F316H  | (11) (17) (22)           | -325                            | 75                              | 30    | 20.0   | 20.0 | 20.0 |
| 18Cr-10Ni-Cb   | A403      | 8                   | WP347H | (27) (31)                | -325                            | 75                              | 30    | 20.0   | 20.0 | 20.0 |
| 18Cr-10Ni-Cb   | A182      | 8                   | F347   | (11) (17) (24)           | -425                            | 75                              | 30    | 20.0   | 20.0 | 20.0 |

**Table IX-1A**  
**Basic Allowable Stresses in Tension for Metal Piping Materials (Cont'd)**

Specifications Are ASTM Unless Otherwise Indicated

| Basic Allowable Stress, S, ksi [Note (3)], at Metal Temperature, °F          |      |      |      |      |      |      |      |      |      |       |        |           |
|--|------|------|------|------|------|------|------|------|------|-------|--------|-----------|
| 400  | 500  | 600  | 650  | 700  | 750  | 800  | 850  | 900  | 950  | 1,000 | Grade  | Spec. No. |
| <b>Stainless Steel [Notes (6), (7)]— Pipes and Tubes [Note (5)] (Cont'd)</b> |      |      |      |      |      |      |      |      |      |       |        |           |
| 20.0   | 20.0 | 19.3 | 19.0 | 18.7 | 18.5 | 18.3 | 18.2 | 18.1 | 18.1 | 18.1  | TP347H | A376      |
| 20.0   | 20.0 | 19.3 | 19.0 | 18.7 | 18.5 | 18.3 | 18.2 | 18.1 | 18.1 | 18.1  | TP347  | A312      |
| 20.0   | 20.0 | 19.3 | 19.0 | 18.7 | 18.5 | 18.3 | 18.2 | 18.1 | 18.1 | 18.1  | 347    | A358      |
| 20.0   | 20.0 | 19.3 | 19.0 | 18.7 | 18.5 | 18.3 | 18.2 | 18.1 | 18.1 | 18.1  | TP347  | A376      |
| 20.0   | 20.0 | 19.3 | 19.0 | 18.7 | 18.5 | 18.3 | 18.2 | 18.1 | 18.1 | 18.1  | TP347  | A409      |
| 20.0   | 20.0 | 19.3 | 19.0 | 18.7 | 18.5 | 18.3 | 18.2 | 18.1 | 18.1 | 18.1  | TP347H | A312      |
| 18.7   | 17.5 | 16.6 | 16.2 | 15.8 | 15.5 | 15.3 | 14.9 | 14.6 | 14.3 | 14.0  | TP304  | A213      |
| 18.7   | 17.5 | 16.6 | 16.2 | 15.8 | 15.5 | 15.3 | 14.9 | 14.6 | 14.3 | 14.0  | TP304N | A249      |
| 18.7   | 17.5 | 16.6 | 16.2 | 15.8 | 15.5 | 15.3 | 14.9 | 14.6 | 14.3 | 14.0  | TP304  | A269      |
| 18.7   | 17.5 | 16.6 | 16.2 | 15.8 | 15.5 | 15.3 | 14.9 | 14.6 | 14.3 | 14.0  | TP304  | A312      |
| 18.7   | 17.5 | 16.6 | 16.2 | 15.8 | 15.5 | 15.3 | 14.9 | 14.6 | 14.3 | 14.0  | 304    | A358      |
| 18.7   | 17.5 | 16.6 | 16.2 | 15.8 | 15.5 | 15.3 | 14.9 | 14.6 | 14.3 | 14.0  | TP304  | A376      |
| 18.7   | 17.5 | 16.6 | 16.2 | 15.8 | 15.5 | 15.3 | 14.9 | 14.6 | 14.3 | 14.0  | TP304H | A376      |
| 18.7   | 17.5 | 16.6 | 16.2 | 15.8 | 15.5 | 15.3 | 14.9 | 14.6 | 14.3 | 14.0  | TP304  | A409      |
| 18.7   | 17.5 | 16.6 | 16.2 | 15.8 | 15.5 | 15.3 | 14.9 | 14.6 | 14.3 | 14.0  | TP304H | A312      |
| 17.0   | 15.8 | 15.0 | 14.7 | 14.4 | 14.2 | 14.1 | 13.9 | 13.7 | 13.4 | 13.1  | CPF8M  | A451      |
| <b>Stainless Steel [Notes (6), (7)] — Plates and Sheets</b>                  |      |      |      |      |      |      |      |      |      |       |        |           |
| 15.8   | 14.7 | 14.0 | 13.7 | 13.5 | 13.3 | 13.0 | 12.8 | 12.6 | 12.3 | 12.0  | 304L   | A240      |
| 15.7   | 14.8 | 14.0 | 13.7 | 13.5 | 13.2 | 12.9 | 12.7 | 12.4 | 12.1 | 11.8  | 316L   | A240      |
| 20.0   | 20.0 | 19.3 | 19.0 | 18.7 | 18.5 | 18.3 | 18.2 | 18.1 | 18.1 | 16.0  | 347    | A240      |
| 19.3   | 18.0 | 17.0 | 16.6 | 16.3 | 16.1 | 15.9 | 15.7 | 15.5 | 15.4 | 15.3  | 316    | A240      |
| 20.0   | 20.0 | 19.3 | 19.0 | 18.7 | 18.5 | 18.3 | 18.2 | 18.1 | 18.1 | 18.1  | 347    | A240      |
| 18.6   | 17.5 | 16.6 | 16.2 | 15.8 | 15.5 | 15.2 | 14.9 | 14.6 | 14.3 | 14.0  | 304    | A240      |
| <b>Stainless Steel [Notes (6), (7)] — Forgings and Fittings [Note (5)]</b>   |      |      |      |      |      |      |      |      |      |       |        |           |
| 15.8   | 14.7 | 14.0 | 13.7 | 13.5 | 13.3 | 13.0 | 12.8 | 12.6 | 12.3 | 12.0  | F304L  | A182      |
| 15.8   | 14.7 | 14.0 | 13.7 | 13.5 | 13.3 | 13.0 | 12.8 | 12.6 | 12.3 | 12.0  | WP304L | A403      |
| 15.7   | 14.8 | 14.0 | 13.7 | 13.5 | 13.2 | 13.9 | 12.7 | 12.4 | 12.1 | 11.8  | F316L  | A182      |
| 15.7   | 14.8 | 14.0 | 13.7 | 13.5 | 13.2 | 13.9 | 12.7 | 12.4 | 12.1 | 11.8  | WP316L | A403      |
| 20.0   | 20.0 | 19.3 | 19.0 | 18.7 | 18.5 | 18.3 | 18.2 | 18.1 | 18.1 | 16.0  | F347   | A182      |
| 20.0   | 20.0 | 19.3 | 19.0 | 18.7 | 18.5 | 18.3 | 18.2 | 18.1 | 18.1 | 16.0  | WP347  | A403      |
| 19.3   | 18.0 | 17.0 | 16.6 | 16.3 | 16.1 | 15.9 | 15.7 | 15.6 | 15.4 | 15.3  | WP316H | A403      |
| 19.3   | 18.0 | 17.0 | 16.6 | 16.3 | 16.1 | 15.9 | 15.7 | 15.6 | 15.4 | 15.3  | F316H  | A182      |
| 20.0   | 19.3 | 19.0 | 18.7 | 18.5 | 18.3 | 18.2 | 18.1 | 18.1 | 18.1 | 18.0  | WP347H | A403      |
| 20.0   | 19.3 | 19.0 | 18.7 | 18.5 | 18.3 | 18.2 | 18.1 | 18.1 | 18.1 | 18.0  | F347   | A182      |



**Table IX-1A**  
**Basic Allowable Stresses in Tension for Metal Piping Materials (Cont'd)**

Specifications Are ASTM Unless Otherwise Indicated

| Material   | Spec. No. | P-No.<br>[Note (1)] | Grade  | Notes               | Min.<br>Temp., °F<br>[Note (2)] | Specified Min.<br>Strength, ksi |       | Basic Allowable<br>Stress, S, ksi<br>[Note (3)], at Metal<br>Temperature, °F |      |      |
|--|-----------|---------------------|--------|---------------------|---------------------------------|---------------------------------|-------|--|------|------|
|  |           |                     |        |                     |                                 | Tensile                         | Yield | Min.<br>Temp.<br>to 100  | 200  | 300  |
| <b>Stainless Steel [Notes (6), (7)] — Forgings and Fittings [Note (5)]</b> |           |                     |        |                     |                                 |                                 |       |  |      |      |
| 18Cr-10Ni-Cb   | A403      | 8                   | WP347  | (24) (27) (31)      | -425                            | 75                              | 30    | 20.0   | 20.0 | 20.0 |
| 18Cr-10Ni-Cb   | A182      | 8                   | F347H  | (11) (17)           | -325                            | 75                              | 30    | 20.0   | 20.0 | 20.0 |
| 18Cr-10Ni-Cb   | A182      | 8                   | F348H  | (11) (17)           | -325                            | 75                              | 30    | 20.0   | 20.0 | 20.0 |
| 16Cr-12Ni-2Mo  | A182      | 8                   | F316   | (11) (17) (22) (24) | -325                            | 75                              | 30    | 20.0   | 20.0 | 20.0 |
| 16Cr-12Ni-2Mo  | A403      | 8                   | WP316  | (22) (24) (27) (31) | -425                            | 75                              | 30    | 20.0   | 20.0 | 20.0 |
| 18Cr-8Ni   | A182      | 8                   | F304   | (11) (17) (22) (24) | -425                            | 75                              | 30    | 20.0   | 20.0 | 20.0 |
| 18Cr-8Ni   | A403      | 8                   | WP304  | (22) (24) (27) (31) | -425                            | 75                              | 30    | 20.0   | 20.0 | 20.0 |
| 18Cr-8Ni   | A403      | 8                   | WP304H | (22) (27) (31)      | -325                            | 75                              | 30    | 20.0   | 20.0 | 20.0 |
| 18Cr-8Ni   | A182      | 8                   | F304H  | (11) (17) (22)      | -325                            | 75                              | 30    | 20.0   | 20.0 | 20.0 |
| <b>Stainless Steel [Notes (6), (7)] — Bar</b>                              |           |                     |        |                     |                                 |                                 |       |  |      |      |
| 18Cr-8Ni   | A479      | 8                   | 304    | (22) (24) (26)      | -425                            | 75                              | 30    | 20.0   | 20.0 | 20.0 |
| <b>Stainless Steel [Notes (6), (7)] — Castings [Note (5)]</b>              |           |                     |        |                     |                                 |                                 |       |  |      |      |
| 18Cr-8Ni   | A351      | 8                   | CF3    | (11)                | -425                            | 70                              | 30    | 20.0   | 20.0 | 20.0 |
| 17Cr-10Ni-2Mo  | A351      | 8                   | CF3M   | (11)                | -425                            | 70                              | 30    | 20.0   | 20.0 | 20.0 |
| 18Cr-8Ni   | A351      | 8                   | CF8    | (11) (22) (23) (26) | -425                            | 70                              | 30    | 20.0   | 20.0 | 20.0 |
| 18Cr-10Ni-2Mo  | A351      | 8                   | CF8M   | (11) (22) (23) (25) | -425                            | 70                              | 30    | 20.0   | 20.0 | 20.0 |
| 18Cr-8Ni   | A351      | 8                   | CF3A   | (11) (37)           | -425                            | 77                              | 35    | 23.3   | 23.3 | 22.7 |
| 18Cr-8Ni   | A351      | 8                   | CF8A   | (11) (22) (37)      | -425                            | 77                              | 35    | 23.3   | 23.3 | 22.7 |

**Table IX-1A**  
**Basic Allowable Stresses in Tension for Metal Piping Materials (Cont'd)**  
 Specifications Are ASTM Unless Otherwise Indicated

| Basic Allowable Stress, S, ksi [Note (3)], at Metal Temperature, °F                 |      |      |      |      |      |      |      |      |      |             |        |           |
|---|------|------|------|------|------|------|------|------|------|-------------|--------|-----------|
| 400   | 500  | 600  | 650  | 700  | 750  | 800  | 850  | 900  | 950  | 1,000       | Grade  | Spec. No. |
| <b>Stainless Steel [Notes (6), (7)] — Forgings and Fittings [Note (5)] (Cont'd)</b> |      |      |      |      |      |      |      |      |      |             |        |           |
| 20.0  | 19.3 | 19.0 | 18.7 | 18.5 | 18.3 | 18.2 | 18.1 | 18.1 | 18.1 | 18.0        | WP347  | A403      |
| 20.0  | 19.3 | 19.0 | 18.7 | 18.5 | 18.3 | 18.2 | 18.1 | 18.1 | 18.1 | <b>18.0</b> | F347H  | A182      |
| 20.0  | 19.3 | 19.0 | 18.7 | 18.5 | 18.3 | 18.2 | 18.1 | 18.1 | 18.1 | 18.0        | F348H  | A182      |
| 19.3  | 18.0 | 17.0 | 16.6 | 16.3 | 16.1 | 15.9 | 15.7 | 15.6 | 15.4 | 15.3        | F316   | A182      |
| 19.3  | 18.0 | 17.0 | 16.6 | 16.3 | 16.1 | 15.9 | 15.7 | 15.6 | 15.4 | 15.3        | WP316  | A403      |
| 18.6  | 17.5 | 16.6 | 16.2 | 15.8 | 15.5 | 15.2 | 14.9 | 14.6 | 14.3 | 14.0        | F304   | A182      |
| 18.6  | 17.5 | 16.6 | 16.2 | 15.8 | 15.5 | 15.2 | 14.9 | 14.6 | 14.3 | 14.0        | WP304  | A403      |
| 18.6  | 17.5 | 16.6 | 16.2 | 15.8 | 15.5 | 15.2 | 14.9 | 14.6 | 14.3 | 14.0        | WP304H | A403      |
| 18.6  | 17.5 | 16.6 | 16.2 | 15.8 | 15.5 | 15.2 | 14.9 | 14.6 | 14.3 | 14.0        | F304H  | A182      |
| <b>Stainless Steel [Notes (6), (7)] — Bar</b>                                       |      |      |      |      |      |      |      |      |      |             |        |           |
| 18.6  | 17.5 | 16.6 | 16.2 | 15.8 | 15.5 | 15.2 | 14.9 | 14.6 | 14.3 | 14.0        | 304    | A479      |
| <b>Stainless Steel [Notes (6), (7)] — Castings [Note (5)]</b>                       |      |      |      |      |      |      |      |      |      |             |        |           |
| 18.6  | 17.5 | 16.6 | 16.2 | 15.8 | 15.5 | 15.2 | ...  | ...  | ...  | ...         | CF3    | A351      |
| 19.2  | 17.9 | 17.0 | 16.6 | 16.3 | 16.0 | 15.8 | 15.7 | ...  | ...  | ...         | CF3M   | A351      |
| 18.6  | 17.5 | 16.6 | 16.2 | 15.8 | 15.5 | 15.2 | 14.9 | 14.6 | 14.3 | 12.2        | CF8    | A351      |
| 18.6  | 17.5 | 16.6 | 16.2 | 15.8 | 15.5 | 15.2 | 14.9 | 14.6 | 14.3 | 14.0        | CF8M   | A351      |
| 21.7  | 20.4 | 19.3 | 18.9 | 18.5 | ...  | ...  | ...  | ...  | ...  | ...         | CF3A   | A351      |
| 21.7  | 20.4 | 19.3 | 18.9 | 18.5 | ...  | ...  | ...  | ...  | ...  | ...         | CF8A   | A351      |

**Table IX-1A**  
**Basic Allowable Stresses in Tension for Metal Piping Materials (Cont'd)**

Specifications Are ASTM Unless Otherwise Indicated

| Material  | Spec. No. | P-No. [Notes (1), (4)] | UNS No.                | Temper [Note (8)] | Size Range, in. | Notes          | Min. Temp., °F [Note (2)] | Specified Min. Strength, ksi |       |
|---|-----------|------------------------|------------------------|-------------------|-----------------|----------------|---------------------------|------------------------------|-------|
|   |           |                        |                        |                   |                 |                |                           | Tensile                      | Yield |
| <b>Copper and Copper Alloy — Pipes and Tubes [Note (5)]</b>       |           |                        |                        |                   |                 |                |                           |                              |       |
| Cu pipe   | B42       | 31                     | C10200, C12000, C12200 | O61               | ...             | ...            | -452                      | 30                           | 9     |
| Cu tube   | B75       | 31                     | C10200, C12000, C12200 | O50, O60          | ...             | ...            | -452                      | 30                           | 9     |
| Cu tube   | B68       | 31                     | C12200                 | O50, O60          | ...             | (21)           | -452                      | 30                           | 9     |
| Cu tube   | B88       | 31                     | C12200                 | O50, O60          | ...             | (21)           | -452                      | 30                           | 9     |
| Cu tube   | B280      | 31                     | C12200                 | O60               | ...             | (21)           | -452                      | 30                           | 9     |
| Red brass pipe  | B43       | 32                     | C23000                 | O61               | ...             | ...            | -452                      | 40                           | 12    |
| 90Cu-10Ni   | B467      | 34                     | C70600                 | W050, W061        | >4.5 O.D.       | (15)           | -452                      | 38                           | 13    |
| 90Cu-10Ni   | B466      | 34                     | C70600                 | Annealed          | ...             | (15)           | -452                      | 38                           | 13    |
| 90Cu-10Ni   | B467      | 34                     | C70600                 | W050, W061        | ≤4.5 O.D.       | (15)           | -452                      | 40                           | 15    |
| 70Cu-30Ni   | B467      | 34                     | C71500                 | W050, W061        | >4.5 O.D.       | (15)           | -452                      | 45                           | 15    |
| 80Cu-20Ni   | B466      | 34                     | C71000                 | Annealed          | ≤4.5 O.D.       | (15)           | -452                      | 45                           | 16    |
| Cu pipe   | B42       | 31                     | C10200, C12000, C12200 | H55               | NPS 2½ thru 12  | (15) (29)      | -452                      | 36                           | 30    |
| Cu tube   | B75       | 31                     | C10200, C12000, C12200 | H58               | ...             | (15) (29)      | -452                      | 36                           | 30    |
| Cu tube   | B88       | 31                     | C12200                 | H55               | ...             | (15) (21) (29) | -452                      | 36                           | 30    |
| 70Cu-30Ni   | B466      | 34                     | C71500                 | O60               | ...             | (15)           | -452                      | 52                           | 18    |
| 70Cu-30Ni   | B467      | 34                     | C71500                 | W050, W061        | ≤4.5 O.D.       | (15)           | -452                      | 50                           | 20    |
| Cu pipe   | B42       | 31                     | C10200, C12000, C12200 | H80               | NPS ⅛ thru 2    | (15) (29)      | -452                      | 45                           | 40    |
| Cu tube   | B75       | 31                     | C10200, C12000, C12200 | H80               | ...             | (15) (29)      | -452                      | 45                           | 40    |
| <b>Copper and Copper Alloy — Plates and Sheets</b>                |           |                        |                        |                   |                 |                |                           |                              |       |
| Cu  | B152      | 31                     | C10200, C10400, C10500 | O25               | ...             | (15) (21)      | -452                      | 30                           | 10    |
| Cu  | B152      | 31                     | C10700, C12200, C12300 | O25               | ...             | (15) (21)      | -452                      | 30                           | 10    |
| 90Cu-10Ni   | B171      | 34                     | C70600                 | ...               | ≤2.5 thk.       | (15)           | -452                      | 40                           | 15    |
| Cu-Si   | B96       | 33                     | C65500                 | O61               | ...             | ...            | -452                      | 52                           | 18    |
| 70Cu-30Ni   | B171      | 34                     | C71500                 | ...               | ≤2.5 thk.       | (15)           | -452                      | 50                           | 20    |
| Al-bronze   | B169      | 35                     | C61400                 | O25, O60          | ≤2.0 thk.       | (14)           | -452                      | 70                           | 30    |
| <b>Copper and Copper Alloy — Forgings</b>                         |           |                        |                        |                   |                 |                |                           |                              |       |
| Cu  | B283      | 31                     | C11000                 | ...               | ...             | (15)           | -452                      | 33                           | 11    |
| High Si-bronze (A)  | B283      | 33                     | C65500                 | ...               | ...             | (15)           | -452                      | 52                           | 18    |
| Forging brass   | B283      | a                      | C37700                 | ...               | ...             | (15)           | -325                      | 58                           | 23    |
| Leaded naval brass  | B283      | a                      | C48500                 | ...               | ...             | (15)           | -325                      | 62                           | 24    |
| Naval brass   | B283      | 32                     | C46400                 | ...               | ...             | (15)           | -425                      | 64                           | 26    |
| Mn-bronze (A)   | B283      | 32                     | C67500                 | ...               | ...             | (15)           | -325                      | 72                           | 34    |
| <b>Copper and Copper Alloy — Castings [Notes (5), (52), (53)]</b> |           |                        |                        |                   |                 |                |                           |                              |       |
| Composition bronze  | B62       | a                      | C83600                 | ...               | ...             | (11)           | -325                      | 30                           | 14    |
| Leaded Ni-bronze  | B584      | a                      | C97300                 | ...               | ...             | ...            | -325                      | 30                           | 15    |
| Leaded Ni-bronze  | B584      | a                      | C97600                 | ...               | ...             | ...            | -325                      | 40                           | 17    |

**Table IX-1A**  
**Basic Allowable Stresses in Tension for Metal Piping Materials (Cont'd)**  
 Specifications Are ASTM Unless Otherwise Indicated

| Basic Allowable Stress, S, ksi [Note (3)], at Metal Temperature, °F |      |      |      |      |      |      |      |      |      |      |      |      |              |           |
|---|------|------|------|------|------|------|------|------|------|------|------|------|--------------|-----------|
| Mill. Temp, to 100  | 150  | 200  | 250  | 300  | 350  | 400  | 450  | 500  | 550  | 600  | 650  | 700  | UNS No.      | Spec. No. |
| <b>Copper and Copper Alloy — Pipes and Tubes [Note (5)]</b>         |      |      |      |      |      |      |      |      |      |      |      |      |              |           |
| 6.0   | 5.1  | 4.9  | 4.8  | 4.7  | 4.0  | 3.0  | 2.3  | 1.7  | ...  | ...  | ...  | ...  | C10200, etc. | B42       |
| 6.0   | 5.1  | 4.9  | 4.8  | 4.7  | 4.0  | 3.0  | 2.3  | 1.7  | ...  | ...  | ...  | ...  | C10200, etc. | B75       |
| 6.0   | 5.1  | 4.9  | 4.8  | 4.7  | 4.0  | 3.0  | 2.3  | 1.7  | ...  | ...  | ...  | ...  | C12200       | B68       |
| 6.0   | 5.1  | 4.9  | 4.8  | 4.7  | 4.0  | 3.0  | 2.3  | 1.7  | ...  | ...  | ...  | ...  | C12200       | B88       |
| 6.0   | 5.1  | 4.9  | 4.8  | 4.7  | 4.0  | 3.0  | 2.3  | 1.7  | ...  | ...  | ...  | ...  | C12200       | B280      |
| 8.0   | 7.9  | 7.9  | 7.9  | 7.9  | 7.0  | 5.0  | 2.0  | ...  | ...  | ...  | ...  | ...  | C23000       | B43       |
| 8.7   | 8.4  | 8.2  | 8.0  | 7.8  | 7.7  | 7.5  | 7.4  | 7.3  | 7.0  | 6.0  | ...  | ...  | C70600       | B467      |
| 8.7   | 8.4  | 8.2  | 8.0  | 7.8  | 7.7  | 7.5  | 7.4  | 7.3  | 7.0  | 6.0  | ...  | ...  | C70600       | B466      |
| 10.0  | 9.7  | 9.5  | 9.3  | 9.1  | 8.9  | 8.7  | 8.5  | 8.0  | 7.0  | 6.0  | ...  | ...  | C70600       | B467      |
| 10.0  | 9.6  | 9.4  | 9.2  | 9.0  | 8.8  | 8.6  | 8.4  | 8.2  | 8.1  | 8.0  | 7.9  | 7.8  | C71500       | B467      |
| 10.7  | 10.6 | 10.5 | 10.4 | 10.2 | 10.1 | 9.9  | 9.6  | 9.3  | 8.9  | 8.4  | 7.7  | 7.0  | C71000       | B466      |
| 12.0  | 11.6 | 10.9 | 10.4 | 10.0 | 9.8  | 9.5  | ...  | ...  | ...  | ...  | ...  | ...  | C10200, etc. | B42       |
| 12.0  | 11.6 | 10.9 | 10.4 | 10.0 | 9.8  | 9.5  | ...  | ...  | ...  | ...  | ...  | ...  | C10200, etc. | B75       |
| 12.0  | 11.6 | 10.9 | 10.4 | 10.0 | 9.8  | 9.5  | ...  | ...  | ...  | ...  | ...  | ...  | C12200       | B88       |
| 12.0  | 11.6 | 11.3 | 11.0 | 10.8 | 10.6 | 10.3 | 10.1 | 9.9  | 9.8  | 9.6  | 9.5  | 9.4  | C71500       | B466      |
| 13.3  | 12.9 | 12.6 | 12.3 | 12.0 | 11.7 | 11.5 | 11.2 | 11.0 | 10.8 | 10.7 | 10.5 | 10.4 | C71500       | B467      |
| 15.0  | 14.5 | 13.6 | 13.0 | 12.6 | 12.2 | 4.3  | ...  | ...  | ...  | ...  | ...  | ...  | C10200, etc. | B42       |
| 15.0  | 14.5 | 13.6 | 13.0 | 12.6 | 12.2 | 4.3  | ...  | ...  | ...  | ...  | ...  | ...  | C10200, etc. | B75       |
| <b>Copper and Copper Alloy — Plates and Sheets</b>                  |      |      |      |      |      |      |      |      |      |      |      |      |              |           |
| 6.7   | 5.7  | 5.4  | 5.3  | 5.0  | 4.0  | 3.0  | 2.3  | 1.7  | ...  | ...  | ...  | ...  | C10200, etc. | B152      |
| 6.7   | 5.7  | 5.4  | 5.3  | 5.0  | 4.0  | 3.0  | 2.3  | 1.7  | ...  | ...  | ...  | ...  | C10700, etc. | B152      |
| 10.0  | 9.7  | 9.5  | 9.3  | 9.1  | 8.9  | 8.7  | 8.5  | 8.0  | 7.0  | 6.0  | ...  | ...  | C70600       | B171      |
| 12.0  | 11.9 | 11.9 | 11.7 | 11.6 | 10.0 | ...  | ...  | ...  | ...  | ...  | ...  | ...  | C65500       | B96       |
| 13.3  | 12.9 | 12.6 | 12.3 | 12.0 | 11.7 | 11.5 | 11.2 | 11.0 | 10.8 | 10.7 | 10.5 | 10.4 | C71500       | B171      |
| 20.0  | 19.9 | 19.8 | 19.7 | 19.5 | 19.4 | 19.2 | 19.0 | 18.8 | ...  | ...  | ...  | ...  | C61400       | B169      |
| <b>Copper and Copper Alloy — Forgings</b>                           |      |      |      |      |      |      |      |      |      |      |      |      |              |           |
| 7.3   | 6.2  | 6.0  | 5.8  | 5.0  | 4.0  | 3.0  | 2.3  | 1.7  | ...  | ...  | ...  | ...  | C11000       | B283      |
| 12.0  | 11.9 | 11.9 | 11.7 | 11.6 | 10.0 | 6.7  | ...  | ...  | ...  | ...  | ...  | ...  | C65500       | B283      |
| 15.3  | 14.5 | 13.9 | 13.3 | 10.5 | 7.5  | 2.0  | ...  | ...  | ...  | ...  | ...  | ...  | C37700       | B283      |
| 16.0  | 16.0 | 16.0 | 16.0 | 16.0 | 16.0 | 16.0 | ...  | ...  | ...  | ...  | ...  | ...  | C48500       | B283      |
| 17.3  | 17.3 | 17.3 | 17.3 | 17.1 | 6.3  | 2.5  | ...  | ...  | ...  | ...  | ...  | ...  | C46400       | B283      |
| 22.7  | 22.7 | 22.7 | 22.7 | 22.7 | 22.7 | 22.7 | ...  | ...  | ...  | ...  | ...  | ...  | C67500       | B283      |
| <b>Copper and Copper Alloy — Castings [Notes (5), (52), (53)]</b>   |      |      |      |      |      |      |      |      |      |      |      |      |              |           |
| 9.3   | 9.3  | 9.2  | 8.6  | 8.1  | 7.7  | 7.4  | 7.3  | ...  | ...  | ...  | ...  | ...  | C83600       | B62       |
| 10.0  | ...  | ...  | ...  | ...  | ...  | ...  | ...  | ...  | ...  | ...  | ...  | ...  | C97300       | B584      |
| 11.3  | 10.1 | 9.5  | 9.1  | 8.7  | ...  | ...  | ...  | ...  | ...  | ...  | ...  | ...  | C97600       | B584      |

**Table IX-1A**  
**Basic Allowable Stresses in Tension for Metal Piping Materials (Cont'd)**

Specifications Are ASTM Unless Otherwise Indicated

| Material  | Spec. No. | P-No. [Notes (1), (4)] | UNS No. | Temper [Note (8)] | Size Range, in. | Notes | Min. Temp., °F [Note (2)] | Specified Min. Strength, ksi |       |
|---|-----------|------------------------|---------|-------------------|-----------------|-------|---------------------------|------------------------------|-------|
|   |           |                        |         |                   |                 |       |                           | Tensile                      | Yield |
| <b>Copper and Copper Alloy — Castings [Notes (5), (52), (53)]</b> |           |                        |         |                   |                 |       |                           |                              |       |
| Leaded Sn-bronze  | B584      | a                      | C92300  | ...               | ...             | ...   | -325                      | 36                           | 16    |
| Leaded Sn-bronze  | B584      | a                      | C92200  | ...               | ...             | ...   | -325                      | 34                           | 16    |
| Steam bronze  | B61       | a                      | C92200  | ...               | ...             | (11)  | -325                      | 34                           | 16    |
| Sn-bronze   | B584      | b                      | C90300  | ...               | ...             | ...   | -325                      | 40                           | 18    |
| Sn-bronze   | B584      | b                      | C90500  | ...               | ...             | ...   | -325                      | 40                           | 18    |
| Leaded Mn-bronze  | B584      | a                      | C86400  | ...               | ...             | (11)  | -325                      | 60                           | 20    |
| Leaded Ni-bronze  | B584      | a                      | C97800  | ...               | ...             | ...   | -325                      | 50                           | 22    |
| No. 1 Mn-bronze   | B584      | b                      | C86500  | ...               | ...             | ...   | -325                      | 65                           | 25    |
| Al-bronze   | B148      | 35                     | C95200  | ...               | ...             | (11)  | -425                      | 65                           | 25    |
| Al-bronze   | B148      | 35                     | C95300  | ...               | ...             | ...   | -425                      | 65                           | 25    |
| Si-Al-bronze  | B148      | 35                     | C95600  | ...               | ...             | ...   | -325                      | 60                           | 28    |
| Al-bronze   | B148      | 35                     | C95400  | ...               | ...             | ...   | -325                      | 75                           | 30    |
| Mn-bronze   | B584      | a                      | C86700  | ...               | ...             | ...   | -325                      | 80                           | 32    |
| Al-bronze   | B148      | 35                     | C95500  | ...               | ...             | ...   | -452                      | 90                           | 40    |
| High strength Mn-bronze   | B584      | b                      | C86200  | ...               | ...             | ...   | -325                      | 90                           | 45    |
| High strength Mn-bronze   | B584      | b                      | C86300  | ...               | ...             | ...   | -325                      | 110                          | 60    |

**Table IX-1A**  
**Basic Allowable Stresses in Tension for Metal Piping Materials (Cont'd)**  
 Specifications Are ASTM Unless Otherwise Indicated

| Basic Allowable Stress, <i>S</i> , ksi [Note (3)], at Metal Temperature, °F |      |      |      |      |      |      |      |      |      |      |     |     |         |           |
|---|------|------|------|------|------|------|------|------|------|------|-----|-----|---------|-----------|
| Mill. Temp, to 100  | 150  | 200  | 250  | 300  | 350  | 400  | 450  | 500  | 550  | 600  | 650 | 700 | UNS No. | Spec. No. |
| <b>Copper and Copper Alloy — Castings [Notes (5), (52), (53)] (Cont'd)</b>  |      |      |      |      |      |      |      |      |      |      |     |     |         |           |
| 10.7  | 10.7 | 10.7 | 10.7 | 10.7 | 10.7 | 10.7 | ...  | ...  | ...  | ...  | ... | ... | C92300  | B584      |
| 10.7  | 9.6  | 9.5  | 9.4  | 9.2  | 8.9  | 8.6  | ...  | ...  | ...  | ...  | ... | ... | C92200  | B584      |
| 10.7  | 9.6  | 9.5  | 9.4  | 9.2  | 8.9  | 8.6  | 8.4  | 8.3  | 8.3  | ...  | ... | ... | C92200  | B61       |
| 12.0  | 12.0 | 12.0 | 12.0 | 12.0 | 12.0 | 12.0 | ...  | ...  | ...  | ...  | ... | ... | C90300  | B584      |
| 12.0  | 12.0 | 12.0 | 12.0 | 12.0 | 12.0 | 12.0 | ...  | ...  | ...  | ...  | ... | ... | C90500  | B584      |
| 13.3  | 13.3 | 13.3 | 13.3 | 13.3 | 13.3 | ...  | ...  | ...  | ...  | ...  | ... | ... | C86400  | B584      |
| 14.7  | 14.7 | 14.7 | 14.7 | 14.7 | 14.7 | ...  | ...  | ...  | ...  | ...  | ... | ... | C97800  | B584      |
| 16.7  | 16.7 | 16.7 | 16.7 | 16.7 | 16.7 | ...  | ...  | ...  | ...  | ...  | ... | ... | C86500  | B584      |
| 16.7  | 15.7 | 15.2 | 14.8 | 14.5 | 14.3 | 14.2 | 14.1 | 14.1 | 11.7 | 7.4  | ... | ... | C95200  | B148      |
| 16.7  | 16.7 | 16.7 | 16.7 | 16.7 | 16.7 | 16.7 | 16.7 | 16.7 | 16.7 | 16.7 | ... | ... | C95300  | B148      |
| 18.7  | ...  | ...  | ...  | ...  | ...  | ...  | ...  | ...  | ...  | ...  | ... | ... | C95600  | B148      |
| 20.0  | 19.0 | 18.7 | 18.5 | 18.5 | 18.5 | 18.5 | 16.0 | 13.9 | ...  | ...  | ... | ... | C95400  | B148      |
| 21.3  | 21.3 | 21.3 | 21.3 | 21.3 | 21.3 | ...  | ...  | ...  | ...  | ...  | ... | ... | C86700  | B584      |
| 26.7  | 26.7 | 26.7 | 26.7 | 26.7 | 26.7 | 26.7 | 26.7 | 26.7 | ...  | ...  | ... | ... | C95500  | B148      |
| 30.0  | 30.0 | 30.0 | 30.0 | 30.0 | 30.0 | ...  | ...  | ...  | ...  | ...  | ... | ... | C86200  | B584      |
| 36.7  | 36.7 | 36.7 | 36.7 | 36.7 | 36.7 | ...  | ...  | ...  | ...  | ...  | ... | ... | C86300  | B584      |

**Table IX-1A**  
**Basic Allowable Stresses in Tension for Metal Piping Materials (Cont'd)**

Specifications Are ASTM Unless Otherwise Indicated

| Material   | Spec. No. | P-No. [Note (1)] | UNS No. | Temper [Note (9)] | Size Range, in.                                | Notes | Min. Temp., °F [Note (2)] | Specified Min. Strength, ksi |       |
|--|-----------|------------------|---------|-------------------|--|-------|---------------------------|------------------------------|-------|
|  |           |                  |         |                   |  |       |                           | Tensile                      | Yield |
| <b>Nickel and Nickel Alloy [Note (7)] — Pipes and Tubes [Note (5)]</b> |           |                  |         |                   |  |       |                           |                              |       |
| Ni-Cu  | B165      | 42               | N04400  | Annealed          | >5 O.D.  | ...   | -325                      | 70                           | 25    |
| Ni-Cu  | B725      | 42               | N04400  | Annealed          | >5 O.D.  | ...   | -325                      | 70                           | 25    |
| Ni-Cu  | B165      | 42               | N04400  | Annealed          | ≤5 O.D.  | ...   | -325                      | 70                           | 28    |
| Ni-Cu  | B725      | 42               | N04400  | Annealed          | ≤5 O.D.  | ...   | -325                      | 70                           | 28    |
| Ni-Cu  | B165      | 42               | N04400  | Str. rel.         | ...  | (35)  | -325                      | 85                           | 55    |
| Ni-Cu  | B725      | 42               | N04400  | Str. rel.         | ...  | (35)  | -325                      | 85                           | 55    |
| <b>Nickel and Nickel Alloy — Plates and Sheets</b>                     |           |                  |         |                   |  |       |                           |                              |       |
| Ni-Cu  | B127      | 42               | N04400  | H.R. plt. ann.    | ...  | ...   | -325                      | 70                           | 28    |
| Ni-Cu  | B127      | 42               | N04400  | H.R. plt. as r.   | ...  | ...   | -325                      | 75                           | 40    |
| <b>Nickel and Nickel Alloy — Forgings and Fittings [Note (5)]</b>      |           |                  |         |                   |  |       |                           |                              |       |
| Ni-Cu  | B564      | 42               | N04400  | Annealed          | ...  | (11)  | -325                      | 70                           | 25    |
| Ni-Cu  | B366      | 42               | N04400  | ...               | ...  | (27)  | -325                      | 70                           | 25    |
| <b>Nickel and Nickel Alloy — Rod and Bar</b>                           |           |                  |         |                   |  |       |                           |                              |       |
| Ni-Cu  | B164      | 42               | N04400  | Ann. forg.        | All  | (14)  | -325                      | 70                           | 25    |
| Ni-Cu  | B164      | 42               | N04400  | H.W.              | All except hex. >2 <sup>1</sup> / <sub>8</sub> | ...   | -325                      | 80                           | 40    |



**Table IX-1A**  
**Basic Allowable Stresses in Tension for Metal Piping Materials (Cont'd)**

Specifications Are ASTM Unless Otherwise Indicated

| Min. Temp. to 100  | 200  | 300  | 400  | 500  | 600  | 650  | 700  | 750  | 800  | 850  | 900 | 950 | 1,000 | UNS No. | Spec. No. |
|--|------|------|------|------|------|------|------|------|------|------|-----|-----|-------|---------|-----------|
| <b>Nickel and Nickel Alloy [Note (7)] — Pipes and Tubes [Note (5)]</b> |      |      |      |      |      |      |      |      |      |      |     |     |       |         |           |
| 16.7   | 14.6 | 13.6 | 13.2 | 13.1 | 13.1 | 13.1 | 13.0 | 12.9 | 12.7 | 11.8 | 8.0 | ... | ...   | N04400  | B165      |
| 16.7   | 14.6 | 13.6 | 13.2 | 13.1 | 13.1 | 13.1 | 13.0 | 12.9 | 12.7 | 11.8 | 8.0 | ... | ...   | N04400  | B725      |
| 18.7   | 16.4 | 15.2 | 14.7 | 14.7 | 14.7 | 14.7 | 14.6 | 14.5 | 14.3 | 11.0 | 8.0 | ... | ...   | N04400  | B165      |
| 18.7   | 16.4 | 15.2 | 14.7 | 14.7 | 14.7 | 14.7 | 14.6 | 14.5 | 14.3 | 11.0 | 8.0 | ... | ...   | N04400  | B725      |
| 28.3   | 28.3 | 28.3 | 28.3 | 28.3 | ...  | ...  | ...  | ...  | ...  | ...  | ... | ... | ...   | N04400  | B165      |
| 28.3   | 28.3 | 28.3 | 28.3 | 28.3 | ...  | ...  | ...  | ...  | ...  | ...  | ... | ... | ...   | N04400  | B725      |
| <b>Nickel and Nickel Alloy — Plates and Sheets</b>                     |      |      |      |      |      |      |      |      |      |      |     |     |       |         |           |
| 18.7   | 16.4 | 15.2 | 14.8 | 14.7 | 14.7 | 14.7 | 14.7 | 14.6 | 14.5 | 11.0 | 8.0 | ... | ...   | N04400  | B127      |
| 25.0   | 25.0 | 24.7 | 23.9 | 23.4 | 23.1 | 22.9 | 22.7 | 20.0 | 14.5 | 8.5  | 4.0 | ... | ...   | N04400  | B127      |
| <b>Nickel and Nickel Alloy — Forgings and Fittings [Note (5)]</b>      |      |      |      |      |      |      |      |      |      |      |     |     |       |         |           |
| 16.7   | 14.6 | 13.6 | 13.2 | 13.1 | 13.1 | 13.1 | 13.0 | 12.9 | 12.7 | 11.0 | 8.0 | ... | ...   | N04400  | B564      |
| 16.7   | 14.7 | 13.7 | 13.2 | 13.2 | 13.2 | 13.2 | 13.2 | 13.0 | 12.7 | 11.0 | 8.0 | ... | ...   | N04400  | B366      |
| <b>Nickel and Nickel Alloy — Rod and Bar</b>                           |      |      |      |      |      |      |      |      |      |      |     |     |       |         |           |
| 16.7   | 14.6 | 13.6 | 13.2 | 13.1 | 13.1 | 13.1 | 13.0 | 12.9 | 12.7 | 11.0 | 8.0 | ... | ...   | N04400  | B164      |
| 26.7   | 25.8 | 24.8 | 23.9 | 23.4 | 23.1 | 22.9 | 22.7 | 20.0 | 14.5 | 8.5  | 4.0 | 1.9 | ...   | N04400  | B164      |

**Table IX-1A**  
**Basic Allowable Stresses in Tension for Metal Piping Materials (Cont'd)**

Specifications Are ASTM Unless Otherwise Indicated

| Spec. No.  | P-No. [Note (1)] | Grade       | Temper        | Size or Thickness Range, in. | Notes     | Min. Temp., °F [Note (2)] | Specified Min. Strength, ksi |     | Basic Allowable Stress, S, ksi [Note (3)] at Metal Temperature, °F |       |               |     |     |     |     |     |     |     |
|--|------------------|-------------|---------------|------------------------------|-----------|---------------------------|------------------------------|-----|--|-------|---------------|-----|-----|-----|-----|-----|-----|-----|
|  |                  |             |               |                              |           |                           |                              |     | Tensile  | Yield | Min. Temp. to | 100 | 150 | 200 | 250 | 300 | 350 | 400 |
|  |                  |             |               |                              |           |                           |                              |     |  |       |               |     |     |     |     |     |     |     |
| <b>Aluminum Alloy — Seamless Pipes and Tubes</b> |                  |             |               |                              |           |                           |                              |     |  |       |               |     |     |     |     |     |     |     |
| B210   | 21               | 1060        | O, H112, H113 | ...                          | (15) (28) | -452                      | 8.5                          | 2.5 | 1.7  | 1.7   | 1.6           | 1.5 | 1.3 | 1.1 | 0.8 |     |     |     |
| B241   | 21               | 1060        | O, H112, H113 | ...                          | (15) (28) | -452                      | 8.5                          | 2.5 | 1.7  | 1.7   | 1.6           | 1.5 | 1.3 | 1.1 | 0.8 |     |     |     |
| B345   | 21               | 1060        | O, H112, H113 | ...                          | (15) (28) | -452                      | 8.5                          | 2.5 | 1.7  | 1.7   | 1.6           | 1.5 | 1.3 | 1.1 | 0.8 |     |     |     |
| B210   | 21               | 1060        | H14           | ...                          | (15) (28) | -452                      | 12                           | 10  | 4.0  | 4.0   | 4.0           | 3.0 | 2.6 | 1.8 | 1.1 |     |     |     |
| B241   | 21               | 1100        | O, H112       | ...                          | (15) (28) | -452                      | 11                           | 3   | 2.0  | 2.0   | 2.0           | 1.9 | 1.7 | 1.3 | 1.0 |     |     |     |
| B210   | 21               | 1100        | H113          | ...                          | (15) (28) | -452                      | 11                           | 3.5 | 2.3  | 2.3   | 2.3           | 2.3 | 1.7 | 1.3 | 1.0 |     |     |     |
| B210   | 21               | 1100        | H14           | ...                          | (15) (28) | -452                      | 16                           | 14  | 5.3  | 5.3   | 5.3           | 4.9 | 2.8 | 1.9 | 1.1 |     |     |     |
| B210   | 21               | 3003        | O, H112       | ...                          | (15) (28) | -452                      | 14                           | 5   | 3.3  | 3.3   | 3.3           | 3.1 | 2.4 | 1.8 | 1.4 |     |     |     |
| B241   | 21               | 3003        | O, H112       | ...                          | (15) (28) | -452                      | 14                           | 5   | 3.3  | 3.3   | 3.3           | 3.1 | 2.4 | 1.8 | 1.4 |     |     |     |
| B345   | 21               | 3003        | O, H112       | ...                          | (15) (28) | -452                      | 14                           | 5   | 3.3  | 3.3   | 3.3           | 3.1 | 2.4 | 1.8 | 1.4 |     |     |     |
| B491   | 21               | 3003        | O, H112       | ...                          | (15) (28) | -452                      | 14                           | 5   | 3.3  | 3.3   | 3.3           | 3.1 | 2.4 | 1.8 | 1.4 |     |     |     |
| B210   | 21               | 3003        | H14           | ...                          | (15) (28) | -452                      | 20                           | 17  | 6.7  | 6.7   | 6.7           | 4.8 | 4.3 | 3.0 | 2.3 |     |     |     |
| B210   | 21               | 3003        | H18           | ...                          | (15) (28) | -452                      | 27                           | 24  | 9.0  | 9.0   | 8.9           | 6.3 | 5.4 | 3.5 | 2.5 |     |     |     |
| B241   | 21               | 3003        | H18           | ...                          | (15) (28) | -452                      | 27                           | 24  | 9.0  | 9.0   | 8.9           | 6.3 | 5.4 | 3.5 | 2.5 |     |     |     |
| B345   | 21               | 3003        | H18           | ...                          | (15) (28) | -452                      | 27                           | 24  | 9.0  | 9.0   | 8.9           | 6.3 | 5.4 | 3.5 | 2.5 |     |     |     |
| B210   | 21               | Alclad 3003 | O, H112       | ...                          | (15) (28) | -452                      | 13                           | 4.5 | 3.0  | 3.0   | 3.0           | 2.8 | 2.2 | 1.6 | 1.3 |     |     |     |
| B241   | 21               | Alclad 3003 | O, H112       | ...                          | (15) (28) | -452                      | 13                           | 4.5 | 3.0  | 3.0   | 3.0           | 2.8 | 2.2 | 1.6 | 1.3 |     |     |     |
| B345   | 21               | Alclad 3003 | O, H112       | ...                          | (15) (28) | -452                      | 13                           | 4.5 | 3.0  | 3.0   | 3.0           | 2.8 | 2.2 | 1.6 | 1.3 |     |     |     |
| B210   | 21               | Alclad 3003 | H14           | ...                          | (15) (28) | -452                      | 19                           | 16  | 6.0  | 6.0   | 6.0           | 4.3 | 3.9 | 2.7 | 2.1 |     |     |     |
| B210   | 21               | Alclad 3003 | H18           | ...                          | (15) (28) | -452                      | 26                           | 23  | 8.1  | 8.1   | 8.0           | 5.7 | 4.9 | 3.2 | 2.2 |     |     |     |
| B210   | 22               | 5052        | O             | ...                          | (15)      | -452                      | 25                           | 10  | 6.7  | 6.7   | 6.7           | 6.2 | 5.6 | 4.1 | 2.3 |     |     |     |
| B241   | 22               | 5052        | O             | ...                          | (15)      | -452                      | 25                           | 10  | 6.7  | 6.7   | 6.7           | 6.2 | 5.6 | 4.1 | 2.3 |     |     |     |
| B210   | 22               | 5052        | H32           | ...                          | (15) (28) | -452                      | 31                           | 23  | 10.3   | 10.3  | 10.3          | 7.5 | 6.2 | 4.1 | 2.3 |     |     |     |
| B210   | 22               | 5052        | H34           | ...                          | (15) (28) | -452                      | 34                           | 26  | 11.3   | 11.3  | 11.3          | 8.4 | 6.2 | 4.1 | 2.3 |     |     |     |
| B241   | 25               | 5083        | O, H112       | ...                          | (28)      | -452                      | 39                           | 16  | 10.7   | 10.7  | ...           | ... | ... | ... | ... |     |     |     |
| B210   | 25               | 5083        | O, H112       | ...                          | (28)      | -452                      | 39                           | 16  | 10.7   | 10.7  | ...           | ... | ... | ... | ... |     |     |     |
| B345   | 25               | 5083        | O, H112       | ...                          | (28)      | -452                      | 39                           | 16  | 10.7   | 10.7  | ...           | ... | ... | ... | ... |     |     |     |
| B241   | 25               | 5086        | O, H112       | ...                          | (28)      | -452                      | 35                           | 14  | 9.3  | 9.3   | ...           | ... | ... | ... | ... |     |     |     |
| B210   | 25               | 5086        | O, H112       | ...                          | (28)      | -452                      | 35                           | 14  | 9.3  | 9.3   | ...           | ... | ... | ... | ... |     |     |     |
| B345   | 25               | 5086        | O, H112       | ...                          | (28)      | -452                      | 35                           | 14  | 9.3  | 9.3   | ...           | ... | ... | ... | ... |     |     |     |
| B210   | 25               | 5086        | H32           | ...                          | (28)      | -452                      | 40                           | 28  | 13.3   | 13.3  | ...           | ... | ... | ... | ... |     |     |     |
| B210   | 25               | 5086        | H34           | ...                          | (28)      | -452                      | 44                           | 34  | 14.7   | 14.7  | ...           | ... | ... | ... | ... |     |     |     |

**Table IX-1A**  
**Basic Allowable Stresses in Tension for Metal Piping Materials (Cont'd)**

Specifications Are ASTM Unless Otherwise Indicated

| Spec. No.   | P-No. [Note (1)] | Grade       | Temper          | Size or Thickness Range, in. | Notes     | Min. Temp., °F [Note (2)] | Specified Min. Strength, ksi |       | Basic Allowable Stress, S, ksi [Note (3)] at Metal Temperature, °F |      |      |      |      |     |     |               |
|---|------------------|-------------|-----------------|------------------------------|-----------|---------------------------|------------------------------|-------|--|------|------|------|------|-----|-----|---------------|
|   |                  |             |                 |                              |           |                           | Tensile                      | Yield | 100  | 150  | 200  | 250  | 300  | 350 | 400 |               |
|   |                  |             |                 |                              |           |                           |                              |       |  |      |      |      |      |     |     | Min. Temp. to |
| <b>Aluminum Alloy — Seamless Pipes and Tubes (Cont'd)</b> |                  |             |                 |                              |           |                           |                              |       |  |      |      |      |      |     |     |               |
| B210  | 22               | 5154        | O               | ...                          | ...       | -452                      | 30                           | 11    | 7.3  | 7.3  | ...  | ...  | ...  | ... |     |               |
| B210  | 22               | 5154        | H34             | ...                          | (28)      | -452                      | 39                           | 29    | 13.3   | 13.0 | ...  | ...  | ...  | ... |     |               |
| B241  | 22               | 5454        | O, H112         | ...                          | (28)      | -452                      | 31                           | 12    | 8.0  | 8.0  | 8.0  | 7.4  | 5.5  | 4.1 | 3.0 |               |
| B210  | 25               | 5456        | O, H112         | ...                          | (28)      | -452                      | 41                           | 19    | 12.7   | 12.7 | ...  | ...  | ...  | ... |     |               |
| B241  | 25               | 5456        | O, H112         | ...                          | (28)      | -452                      | 41                           | 19    | 12.7   | 12.7 | ...  | ...  | ...  | ... |     |               |
| B210  | 23               | 6061        | T4              | ...                          | (28)      | -452                      | 30                           | 16    | 10.0   | 10.0 | 10.0 | 9.8  | 9.2  | 7.9 | 5.6 |               |
| B241  | 23               | 6061        | T4              | ...                          | (28) (41) | -452                      | 26                           | 16    | 8.7  | 8.7  | 8.7  | 8.5  | 8.0  | 7.9 | 5.6 |               |
| B345  | 23               | 6061        | T4              | ...                          | (28) (41) | -452                      | 26                           | 16    | 8.7  | 8.7  | 8.7  | 8.5  | 8.0  | 7.9 | 5.6 |               |
| B210  | 23               | 6061        | T6              | ...                          | (28)      | -452                      | 42                           | 35    | 14.0   | 14.0 | 14.0 | 13.2 | 11.3 | 7.9 | 5.6 |               |
| B241  | 23               | 6061        | T6              | ...                          | (28) (41) | -452                      | 38                           | 35    | 12.7   | 12.7 | 12.7 | 12.1 | 10.6 | 7.9 | 5.6 |               |
| B345  | 23               | 6061        | T6              | ...                          | (28) (41) | -452                      | 38                           | 35    | 12.7   | 12.7 | 12.7 | 12.1 | 10.6 | 7.9 | 5.6 |               |
| B210  | 23               | 6061        | T4, T6 wld.     | ...                          | (19) (41) | -452                      | 24                           | ...   | 8.0  | 8.0  | 8.0  | 7.9  | 7.4  | 6.1 | 4.3 |               |
| B241  | 23               | 6061        | T4, T6 wld.     | ...                          | (19) (41) | -452                      | 24                           | ...   | 8.0  | 8.0  | 8.0  | 7.9  | 7.4  | 6.1 | 4.3 |               |
| B345  | 23               | 6061        | T4, T6 wld.     | ...                          | (19) (41) | -452                      | 24                           | ...   | 8.0  | 8.0  | 8.0  | 7.9  | 7.4  | 6.1 | 4.3 |               |
| B210  | 23               | 6063        | T4              | ...                          | (28)      | -452                      | 22                           | 10    | 6.7  | 6.7  | 6.7  | 6.7  | 6.7  | 3.4 | 2.0 |               |
| B241  | 23               | 6063        | T4              | ≤ 0.500                      | (28)      | -452                      | 19                           | 10    | 6.7  | 6.7  | 6.7  | 6.7  | 6.7  | 3.4 | 2.0 |               |
| B345  | 23               | 6063        | T4              | ≤ 0.500                      | (28)      | -452                      | 19                           | 10    | 6.7  | 6.7  | 6.7  | 6.7  | 6.7  | 3.4 | 2.0 |               |
| B241  | 23               | 6063        | T5              | ≤ 0.500                      | (28)      | -452                      | 22                           | 16    | 7.3  | 7.3  | 7.2  | 6.8  | 6.1  | 3.4 | 2.0 |               |
| B345  | 23               | 6063        | T5              | ≤ 0.500                      | (28)      | -452                      | 22                           | 16    | 7.3  | 7.3  | 7.2  | 6.8  | 6.1  | 3.4 | 2.0 |               |
| B210  | 23               | 6063        | T6              | ...                          | (28)      | -452                      | 33                           | 28    | 11.0   | 11.0 | 10.5 | 9.5  | 7.0  | 3.4 | 2.0 |               |
| B241  | 23               | 6063        | T6              | ...                          | (28)      | -452                      | 30                           | 25    | 10.0   | 10.0 | 9.8  | 9.0  | 6.6  | 3.4 | 2.0 |               |
| B345  | 23               | 6063        | T6              | ...                          | (28)      | -452                      | 30                           | 25    | 10.0   | 10.0 | 9.8  | 9.0  | 6.6  | 3.4 | 2.0 |               |
| B210  | 23               | 6063        | T4, T5, T6 wld. | ...                          | ...       | -452                      | 17                           | ...   | 5.7  | 5.7  | 5.7  | 5.6  | 5.2  | 3.0 | 2.0 |               |
| B241  | 23               | 6063        | T4, T5, T6 wld. | ...                          | ...       | -452                      | 17                           | ...   | 5.7  | 5.7  | 5.7  | 5.6  | 5.2  | 3.0 | 2.0 |               |
| B345  | 23               | 6063        | T4, T5, T6 wld. | ...                          | ...       | -452                      | 17                           | ...   | 5.7  | 5.7  | 5.7  | 5.6  | 5.2  | 3.0 | 2.0 |               |
| <b>Aluminum Alloys — Welded Pipes and Tubes</b>           |                  |             |                 |                              |           |                           |                              |       |  |      |      |      |      |     |     |               |
| B547  | 25               | 5083        | O               | ...                          | ...       | -452                      | 40                           | 18    | 12.0   | 12.0 | ...  | ...  | ...  | ... |     |               |
| <b>Aluminum Alloys — Structural Tubes</b>                 |                  |             |                 |                              |           |                           |                              |       |  |      |      |      |      |     |     |               |
| B221  | 21               | 1060        | O, H112         | ...                          | (28) (46) | -452                      | 8.5                          | 2.5   | 1.7  | 1.7  | 1.6  | 1.5  | 1.3  | 1.1 | 0.8 |               |
| B221  | 21               | 1100        | O, H112         | ...                          | (28) (46) | -452                      | 11                           | 3     | 2.0  | 2.0  | 2.0  | 1.9  | 1.7  | 1.3 | 1.0 |               |
| B221  | 21               | 3003        | O, H112         | ...                          | (28) (46) | -452                      | 14                           | 5     | 3.3  | 3.3  | 3.3  | 3.1  | 2.4  | 1.8 | 1.4 |               |
| B221  | 21               | Alclad 3003 | O, H112         | ...                          | (28) (46) | -452                      | 13                           | 4.5   | 3.0  | 3.0  | 3.0  | 2.8  | 2.2  | 1.6 | 1.3 |               |

**Table IX-1A**  
**Basic Allowable Stresses in Tension for Metal Piping Materials (Cont'd)**

Specifications Are ASTM Unless Otherwise Indicated

| Spec. No.  | P-No. [Note (1)] | Grade       | Temper          | Size or Thickness Range, in. | Notes          | Min. Temp., °F [Note (2)] | Specified Min. Strength, ksi |     | Basic Allowable Stress, S, ksi [Note (3)] at Metal Temperature, °F |       |                   |      |      |     |     |     |     |
|--|------------------|-------------|-----------------|------------------------------|----------------|---------------------------|------------------------------|-----|--|-------|-------------------|------|------|-----|-----|-----|-----|
|  |                  |             |                 |                              |                |                           |                              |     | Tensile  | Yield | Min. Temp. to 100 | 150  | 200  | 250 | 300 | 350 | 400 |
|  |                  |             |                 |                              |                |                           |                              |     |  |       |                   |      |      |     |     |     |     |
| <b>Aluminum Alloys — Structural Tubes (Cont'd)</b> |                  |             |                 |                              |                |                           |                              |     |  |       |                   |      |      |     |     |     |     |
| B221   | 22               | 5052        | O               | ...                          | (46)           | -452                      | 25                           | 10  | 6.7  | 6.7   | 6.7               | 6.2  | 5.6  | 4.1 | 2.3 |     |     |
| B221   | 25               | 5083        | O               | ...                          | (46)           | -452                      | 39                           | 16  | 10.7   | 10.7  | ...               | ...  | ...  | ... | ... |     |     |
| B221   | 25               | 5086        | O               | ...                          | (46)           | -452                      | 35                           | 14  | 9.3  | 9.3   | ...               | ...  | ...  | ... | ... |     |     |
| B221   | 22               | 5154        | O               | ...                          | (46)           | -452                      | 30                           | 11  | 7.3  | 7.3   | ...               | ...  | ...  | ... | ... |     |     |
| B221   | 22               | 5454        | O               | ...                          | (46)           | -452                      | 31                           | 12  | 8.0  | 8.0   | 8.0               | 7.4  | 5.5  | 4.1 | 3.0 |     |     |
| B221   | 25               | 5456        | O               | ...                          | (46)           | -452                      | 41                           | 19  | 12.7   | 12.7  | ...               | ...  | ...  | ... | ... |     |     |
| B221   | 23               | 6061        | T4              | ...                          | (28) (41) (46) | -452                      | 26                           | 16  | 8.7  | 8.7   | 8.7               | 8.5  | 8.0  | 7.7 | 5.3 |     |     |
| B221   | 23               | 6061        | T6              | ...                          | (28) (41) (46) | -452                      | 38                           | 35  | 12.7   | 12.7  | 12.7              | 12.1 | 10.6 | 7.9 | 5.6 |     |     |
| B221   | 23               | 6061        | T4, T6 wld.     | ...                          | (19) (41) (46) | -452                      | 24                           | ... | 8.0  | 8.0   | 8.0               | 7.9  | 7.4  | 6.1 | 4.3 |     |     |
| B221   | 23               | 6063        | T4              | ≤0.500                       | (14) (28) (46) | -452                      | 19                           | 10  | 6.4  | 6.4   | 6.4               | 6.4  | 6.4  | 3.4 | 2.0 |     |     |
| B221   | 23               | 6063        | T5              | ≤0.500                       | (14) (28) (46) | -452                      | 22                           | 16  | 7.3  | 7.3   | 7.2               | 6.8  | 6.1  | 3.4 | 2.0 |     |     |
| B221   | 23               | 6063        | T6              | ...                          | (28) (46)      | -452                      | 30                           | 25  | 10.0   | 10.0  | 9.8               | 9.0  | 6.6  | 3.4 | 2.0 |     |     |
| B221   | 23               | 6063        | T4, T5, T6 wld. | ...                          | (46)           | -452                      | 17                           | ... | 5.7  | 5.7   | 5.7               | 5.6  | 5.2  | 3.0 | 2.0 |     |     |
| <b>Aluminum Alloys — Plates and Sheets</b>         |                  |             |                 |                              |                |                           |                              |     |  |       |                   |      |      |     |     |     |     |
| B209   | 21               | 1060        | O               | ...                          | ...            | -452                      | 8                            | 2.5 | 1.7  | 1.7   | 1.6               | 1.5  | 1.3  | 1.1 | 0.8 |     |     |
| B209   | 21               | 1060        | H112            | 0.500–1.000                  | (14) (28)      | -452                      | 10                           | 5   | 3.3  | 3.2   | 2.9               | 1.9  | 1.7  | 1.4 | 1.0 |     |     |
| B209   | 21               | 1060        | H12             | ...                          | (28)           | -452                      | 11                           | 9   | 3.7  | 3.7   | 3.4               | 2.3  | 2.0  | 1.8 | 1.1 |     |     |
| B209   | 21               | 1060        | H14             | ...                          | (28)           | -452                      | 12                           | 10  | 4.0  | 4.0   | 4.0               | 3.0  | 2.6  | 1.8 | 1.1 |     |     |
| B209   | 21               | 1100        | O               | ...                          | ...            | -452                      | 11                           | 3.5 | 2.3  | 2.3   | 2.3               | 2.3  | 1.7  | 1.3 | 1.0 |     |     |
| B209   | 21               | 1100        | H112            | 0.500–2.000                  | (14) (28)      | -452                      | 12                           | 5   | 3.3  | 3.3   | 3.3               | 2.5  | 2.2  | 1.7 | 1.0 |     |     |
| B209   | 21               | 1100        | H12             | ...                          | (28)           | -452                      | 14                           | 11  | 4.7  | 4.7   | 4.7               | 3.2  | 2.8  | 1.9 | 1.1 |     |     |
| B209   | 21               | 1100        | H14             | ...                          | (28)           | -452                      | 16                           | 14  | 5.3  | 5.3   | 5.3               | 3.7  | 2.8  | 1.9 | 1.1 |     |     |
| B209   | 21               | 3003        | O               | ...                          | ...            | -452                      | 14                           | 5   | 3.3  | 3.3   | 3.3               | 3.1  | 2.4  | 1.8 | 1.4 |     |     |
| B209   | 21               | 3003        | H112            | 0.500–2.000                  | (14) (28)      | -452                      | 15                           | 6   | 4.0  | 4.0   | 3.9               | 3.1  | 2.4  | 1.8 | 1.4 |     |     |
| B209   | 21               | 3003        | H12             | ...                          | (28)           | -452                      | 17                           | 12  | 5.7  | 5.7   | 5.7               | 4.0  | 3.6  | 3.0 | 2.3 |     |     |
| B209   | 21               | 3003        | H14             | ...                          | (28)           | -452                      | 20                           | 17  | 6.7  | 6.7   | 6.7               | 4.8  | 4.3  | 3.0 | 2.3 |     |     |
| B209   | 21               | Alclad 3003 | O               | 0.006–0.499                  | (43)           | -452                      | 13                           | 4.5 | 3.0  | 3.0   | 3.0               | 2.8  | 2.2  | 1.6 | 1.3 |     |     |
| B209   | 21               | Alclad 3003 | O               | 0.500–3.000                  | (45)           | -452                      | 14                           | 5   | 3.0  | 3.0   | 3.0               | 2.8  | 2.2  | 1.6 | 1.3 |     |     |
| B209   | 21               | Alclad 3003 | H112            | 0.500–2.000                  | (28) (43)      | -452                      | 15                           | 6   | 3.6  | 3.6   | 3.5               | 2.8  | 2.2  | 1.6 | 1.3 |     |     |
| B209   | 21               | Alclad 3003 | H12             | 0.017–0.499                  | (28) (43)      | -452                      | 16                           | 11  | 5.1  | 5.1   | 5.1               | 3.6  | 3.2  | 2.7 | 2.1 |     |     |

**Table IX-1A**  
**Basic Allowable Stresses in Tension for Metal Piping Materials (Cont'd)**

Specifications Are ASTM Unless Otherwise Indicated

| Spec. No.   | P-No. [Note (1)] | Grade       | Temper | Size or Thickness Range, in. | Notes     | Min. Temp., °F [Note (2)] | Specified Min. Strength, ksi |       | Basic Allowable Stress, S, ksi [Note (3)] at Metal Temperature, °F |      |      |     |     |     |     |
|---|------------------|-------------|--------|------------------------------|-----------|---------------------------|------------------------------|-------|--|------|------|-----|-----|-----|-----|
|   |                  |             |        |                              |           |                           | Tensile                      | Yield | 100  | 150  | 200  | 250 | 300 | 350 | 400 |
|   |                  |             |        |                              |           |                           |                              |       |  |      |      |     |     |     |     |
| <b>Aluminum Alloys — Plates and Sheets (Cont'd)</b> |                  |             |        |                              |           |                           |                              |       |  |      |      |     |     |     |     |
| B209  | 21               | Alclad 3003 | H12    | 0.500–2.000                  | (28) (45) | –452                      | 17                           | 12    | 5.1  | 5.1  | 5.1  | 3.6 | 3.2 | 2.7 | 2.1 |
| B209  | 21               | Alclad 3003 | H14    | 0.009–0.499                  | (28) (43) | –452                      | 19                           | 16    | 6.0  | 6.0  | 6.0  | 4.3 | 3.9 | 2.7 | 2.1 |
| B209  | 21               | Alclad 3003 | H14    | 0.500–1.000                  | (28) (45) | –452                      | 20                           | 17    | 6.0  | 6.0  | 6.0  | 4.3 | 3.9 | 2.7 | 2.1 |
| B209  | 22               | 3004        | O      | ...                          | ...       | –452                      | 22                           | 8.5   | 5.7  | 5.7  | 5.7  | 5.7 | 5.7 | 3.8 | 2.3 |
| B209  | 22               | 3004        | H112   | ...                          | (28)      | –452                      | 23                           | 9     | 6.0  | 6.0  | 6.0  | 6.0 | 5.8 | 3.8 | 2.3 |
| B209  | 22               | 3004        | H32    | ...                          | (28)      | –452                      | 28                           | 21    | 9.3  | 9.3  | 9.3  | 7.0 | 5.8 | 3.8 | 2.3 |
| B209  | 22               | 3004        | H34    | ...                          | (28)      | –452                      | 32                           | 25    | 10.7   | 10.7 | 10.7 | 8.0 | 5.8 | 3.8 | 2.3 |
| B209  | 22               | Alclad 3004 | O      | 0.006–0.499                  | (43)      | –452                      | 21                           | 8     | 5.1  | 5.1  | 5.1  | 5.1 | 5.1 | 3.4 | 2.1 |
| B209  | 22               | Alclad 3004 | O      | 0.500–3.000                  | (45)      | –452                      | 22                           | 8.5   | 5.1  | 5.1  | 5.1  | 5.1 | 5.1 | 3.4 | 2.1 |
| B209  | 22               | Alclad 3004 | H112   | 0.250–0.499                  | (28) (43) | –452                      | 22                           | 8.5   | 5.4  | 5.4  | 5.4  | 5.4 | 5.2 | 3.4 | 2.1 |
| B209  | 22               | Alclad 3004 | H112   | 0.500–3.000                  | (28) (45) | –452                      | 23                           | 9     | 5.4  | 5.4  | 5.4  | 5.4 | 5.2 | 3.4 | 2.1 |
| B209  | 22               | Alclad 3004 | H32    | 0.017–0.499                  | (28) (43) | –452                      | 27                           | 20    | 8.4  | 8.4  | 8.4  | 6.3 | 5.2 | 3.4 | 2.1 |
| B209  | 22               | Alclad 3004 | H32    | 0.500–2.000                  | (28) (45) | –452                      | 28                           | 21    | 8.4  | 8.4  | 8.4  | 6.3 | 5.2 | 3.4 | 2.1 |
| B209  | 22               | Alclad 3004 | H34    | 0.009–0.499                  | (28) (43) | –452                      | 31                           | 24    | 9.6  | 9.6  | 9.6  | 7.2 | 5.2 | 3.4 | 2.1 |
| B209  | 22               | Alclad 3004 | H34    | 0.500–1.000                  | (28) (45) | –452                      | 32                           | 25    | 9.6  | 9.6  | 9.6  | 7.2 | 5.2 | 3.4 | 2.1 |
| B209  | S-21             | 5050        | O      | ...                          | ...       | –452                      | 18                           | 6     | 4.0  | 4.0  | 4.0  | 4.0 | 4.0 | 2.8 | 1.4 |
| B209  | S-21             | 5050        | H112   | ...                          | (28)      | –452                      | 20                           | 8     | 5.3  | 5.3  | 5.3  | 5.3 | 5.3 | 2.8 | 1.4 |
| B209  | S-21             | 5050        | H32    | ...                          | (28)      | –452                      | 22                           | 16    | 7.3  | 7.3  | 7.3  | 5.5 | 5.3 | 2.8 | 1.4 |
| B209  | S-21             | 5050        | H34    | ...                          | (28)      | –452                      | 25                           | 20    | 8.3  | 8.3  | 8.3  | 6.3 | 5.3 | 2.8 | 1.4 |
| B209  | 22               | 5052 & 5652 | O      | ...                          | ...       | –452                      | 25                           | 9.5   | 6.3  | 6.3  | 6.3  | 6.2 | 5.6 | 4.1 | 2.3 |
| B209  | 22               | 5052 & 5652 | H112   | 0.500–3.000                  | (14) (28) | –452                      | 25                           | 9.5   | 6.3  | 6.3  | 6.3  | 6.2 | 5.6 | 4.1 | 2.3 |
| B209  | 22               | 5052 & 5652 | H32    | ...                          | (28)      | –452                      | 31                           | 23    | 10.3   | 10.3 | 10.3 | 7.5 | 6.2 | 4.1 | 2.3 |
| B209  | 22               | 5052 & 5652 | H34    | ...                          | (28)      | –452                      | 34                           | 26    | 11.3   | 11.3 | 11.3 | 8.4 | 6.2 | 4.1 | 2.3 |
| B209  | 25               | 5083        | O      | 0.051–1.500                  | (14)      | –452                      | 40                           | 18    | 12.0   | 12.0 | ...  | ... | ... | ... | ... |
| B209  | 25               | 5083        | H32    | 0.188–1.500                  | (14) (28) | –452                      | 44                           | 31    | 14.7   | 14.7 | ...  | ... | ... | ... | ... |
| B209  | 25               | 5086        | O      | ...                          | ...       | –452                      | 35                           | 14    | 9.3  | 9.3  | ...  | ... | ... | ... | ... |
| B209  | 25               | 5086        | H112   | 0.500–1.000                  | (14) (28) | –452                      | 35                           | 16    | 9.3  | 9.3  | ...  | ... | ... | ... | ... |
| B209  | 25               | 5086        | H32    | ...                          | (28)      | –452                      | 40                           | 28    | 13.3   | 13.3 | ...  | ... | ... | ... | ... |
| B209  | 25               | 5086        | H34    | ...                          | (28)      | –452                      | 44                           | 34    | 14.7   | 14.7 | ...  | ... | ... | ... | ... |
| B209  | 22               | 5154 & 5254 | O      | ...                          | ...       | –452                      | 30                           | 11    | 7.3  | 7.3  | ...  | ... | ... | ... | ... |
| B209  | 22               | 5154 & 5254 | H112   | 0.500–3.000                  | (14) (28) | –452                      | 30                           | 11    | 7.3  | 7.3  | ...  | ... | ... | ... | ... |
| B209  | 22               | 5154 & 5254 | H32    | ...                          | (28)      | –452                      | 36                           | 26    | 12.0   | 12.0 | ...  | ... | ... | ... | ... |
| B209  | 22               | 5154 & 5254 | H34    | ...                          | (28)      | –452                      | 39                           | 29    | 13.0   | 13.0 | ...  | ... | ... | ... | ... |

**Table IX-1A**  
**Basic Allowable Stresses in Tension for Metal Piping Materials (Cont'd)**

Specifications Are ASTM Unless Otherwise Indicated

| Spec. No.   | P-No. [Note (1)] | Grade          | Temper             | Size or Thickness Range, in. | Notes                         | Min. Temp., °F [Note (2)] | Specified Min. Strength, ksi |     | Basic Allowable Stress, S, ksi [Note (3)] at Metal Temperature, °F |       |               |      |      |     |     |     |     |     |     |     |     |     |     |
|---|------------------|----------------|--------------------|------------------------------|-------------------------------|---------------------------|------------------------------|-----|--|-------|---------------|------|------|-----|-----|-----|-----|-----|-----|-----|-----|-----|-----|
|   |                  |                |                    |                              |                               |                           |                              |     | Tensile  | Yield | Min. Temp. to | 100  | 150  | 200 | 250 | 300 | 350 | 400 |     |     |     |     |     |
|   |                  |                |                    |                              |                               |                           |                              |     |  |       |               |      |      |     |     |     |     |     | 100 | 150 | 200 | 250 | 300 |
| <b>Aluminum Alloys — Plates and Sheets (Cont'd)</b>       |                  |                |                    |                              |                               |                           |                              |     |  |       |               |      |      |     |     |     |     |     |     |     |     |     |     |
| B209  | 22               | 5454           | O                  | ...                          | ...                           | -452                      | 31                           | 12  | 8.0  | 8.0   | 8.0           | 7.4  | 5.5  | 4.1 | 3.0 |     |     |     |     |     |     |     |     |
| B209  | 22               | 5454           | H112               | 0.500-3.000                  | (14) (28)                     | -452                      | 31                           | 12  | 8.0  | 8.0   | 8.0           | 7.4  | 5.5  | 4.1 | 3.0 |     |     |     |     |     |     |     |     |
| B209  | 22               | 5454           | H32                | ...                          | (28)                          | -452                      | 36                           | 26  | 12.0   | 12.0  | 12.0          | 7.5  | 5.5  | 4.1 | 3.0 |     |     |     |     |     |     |     |     |
| B209  | 22               | 5454           | H34                | ...                          | (28)                          | -452                      | 39                           | 29  | 13.0   | 13.0  | 13.0          | 7.5  | 5.5  | 4.1 | 3.0 |     |     |     |     |     |     |     |     |
| B209  | 25               | 5456           | O                  | 0.051-1.500                  | (14)                          | -452                      | 42                           | 19  | 12.7   | 12.7  | ...           | ...  | ...  | ... | ... |     |     |     |     |     |     |     |     |
| B209  | 25               | 5456           | H321               | 0.188-0.499                  | (14) (28)                     | -452                      | 46                           | 33  | 15.3   | 15.3  | ...           | ...  | ...  | ... | ... |     |     |     |     |     |     |     |     |
| B209  | 23               | 6061           | T4                 | ...                          | (28) (41)                     | -452                      | 30                           | 16  | 10.0   | 10.0  | 10.0          | 9.8  | 9.2  | 7.9 | 5.6 |     |     |     |     |     |     |     |     |
| B209  | 23               | 6061           | T6                 | ...                          | (28)                          | -452                      | 42                           | 35  | 14.0   | 14.0  | 14.0          | 13.2 | 11.2 | 7.9 | 5.6 |     |     |     |     |     |     |     |     |
| B209  | 23               | 6061           | T651               | 0.250-4.000                  | (14) (28)                     | -452                      | 42                           | 35  | 14.0   | 14.0  | 14.0          | 13.2 | 11.2 | 7.9 | 5.6 |     |     |     |     |     |     |     |     |
| B209  | 23               | 6061           | T4, T6 wld.        | ...                          | (19) (41)                     | -452                      | 24                           | ... | 8.0  | 8.0   | 8.0           | 7.9  | 7.4  | 6.1 | 4.3 |     |     |     |     |     |     |     |     |
| B209  | 23               | Alclad 6061    | T4                 | ...                          | (28) (43)                     | -452                      | 27                           | 14  | 9.0  | 9.0   | 9.0           | 8.8  | 8.3  | 7.1 | 5.0 |     |     |     |     |     |     |     |     |
| B209  | 23               | Alclad 6061    | T451               | 0.250-0.499                  | (28) (43)                     | -452                      | 27                           | 14  | 9.0  | 9.0   | 9.0           | 8.8  | 8.3  | 7.1 | 5.0 |     |     |     |     |     |     |     |     |
| B209  | 23               | Alclad 6061    | T451               | 0.500-3.000                  | (28) (45)                     | -452                      | 30                           | 16  | 9.0  | 9.0   | 9.0           | 8.8  | 8.3  | 7.1 | 5.0 |     |     |     |     |     |     |     |     |
| B209  | 23               | Alclad 6061    | T6                 | ...                          | (28) (43)                     | -452                      | 38                           | 32  | 12.6   | 12.6  | 12.6          | 11.9 | 10.1 | 7.1 | 5.0 |     |     |     |     |     |     |     |     |
| B209  | 23               | Alclad 6061    | T651               | 0.250-0.499                  | (28) (43)                     | -452                      | 38                           | 32  | 12.6   | 12.6  | 12.6          | 11.9 | 10.1 | 7.1 | 5.0 |     |     |     |     |     |     |     |     |
| B209  | 23               | Alclad 6061    | T651               | 0.500-4.000                  | (28) (45)                     | -452                      | 42                           | 35  | 12.6   | 12.6  | 12.6          | 11.9 | 10.1 | 7.1 | 5.0 |     |     |     |     |     |     |     |     |
| B209  | 23               | Alclad 6061    | T4, T6 wld.        | ...                          | (19) (41)                     | -452                      | 24                           | ... | 8.0  | 8.0   | 8.0           | 7.9  | 7.4  | 6.1 | 4.3 |     |     |     |     |     |     |     |     |
| <b>Aluminum Alloys — Forgings and Fittings [Note (5)]</b> |                  |                |                    |                              |                               |                           |                              |     |  |       |               |      |      |     |     |     |     |     |     |     |     |     |     |
| B247  | 21               | 3003           | H112, H112 wld.    | ...                          | (11) (33)                     | -452                      | 14                           | 5   | 3.3  | 3.3   | 3.3           | 3.1  | 2.4  | 1.8 | 1.4 |     |     |     |     |     |     |     |     |
| B247  | 25               | 5083           | O, H112, H112 wld. | ...                          | (11) (27) (28)                | -452                      | 38                           | 16  | 10.7   | 10.7  | ...           | ...  | ...  | ... | ... |     |     |     |     |     |     |     |     |
| B247  | 23               | 6061           | T6                 | ...                          | (11) (28)                     | -452                      | 38                           | 35  | 12.7   | 12.7  | 12.7          | 12.1 | 10.6 | 7.9 | 5.6 |     |     |     |     |     |     |     |     |
| B247  | 23               | 6061           | T6 wld.            | ...                          | (11) (19)                     | -452                      | 24                           | ... | 8.0  | 8.0   | 8.0           | 7.9  | 7.4  | 6.1 | 4.3 |     |     |     |     |     |     |     |     |
| B361  | 21               | WP1060         | O, H112            | ...                          | (14) (15) (20) (27) (28)      | -452                      | 8                            | 2.5 | 1.7  | 1.7   | 1.6           | 1.5  | 1.3  | 1.1 | 0.8 |     |     |     |     |     |     |     |     |
| B361  | 21               | WP1100         | O, H112            | ...                          | (14) (15) (20) (27) (28)      | -452                      | 11                           | 3   | 2.0  | 2.0   | 2.0           | 1.9  | 1.7  | 1.3 | 1.0 |     |     |     |     |     |     |     |     |
| B361  | 21               | WP3003         | O, H112            | ...                          | (14) (15) (20) (27) (28)      | -452                      | 14                           | 5   | 3.3  | 3.3   | 3.3           | 3.1  | 2.4  | 1.8 | 1.4 |     |     |     |     |     |     |     |     |
| B361  | 21               | WP Alclad 3003 | O, H112            | ...                          | (14) (15) (20) (27) (28) (43) | -452                      | 13                           | 4.5 | 3.0  | 3.0   | 3.0           | 2.8  | 2.2  | 1.6 | 1.3 |     |     |     |     |     |     |     |     |
| B361  | 25               | WP5083         | O, H112            | ...                          | (14) (20) (27) (28)           | -452                      | 39                           | 16  | 10.7   | 10.7  | ...           | ...  | ...  | ... | ... |     |     |     |     |     |     |     |     |
| B361  | 22               | WP5154         | O, H112            | ...                          | (20) (27) (28)                | -452                      | 30                           | 11  | 7.3  | 7.3   | ...           | ...  | ...  | ... | ... |     |     |     |     |     |     |     |     |
| B361  | 23               | WP6061         | T4                 | ...                          | ...                           | -452                      | 26                           | 16  | 8.7  | 8.7   | 8.7           | 8.5  | 8.0  | 7.7 | 5.6 |     |     |     |     |     |     |     |     |

**Table IX-1A**  
**Basic Allowable Stresses in Tension for Metal Piping Materials (Cont'd)**

Specifications Are ASTM Unless Otherwise Indicated

| Spec. No.  | P-No. [Note (1)] | Grade  | Temper      | Size or Thickness Range, in. | Notes                          | Min. Temp., °F [Note (2)] | Specified Min. Strength, ksi |       | Basic Allowable Stress, S, ksi [Note (3)] at Metal Temperature, °F |      |      |      |      |     |     |
|--|------------------|--------|-------------|------------------------------|--------------------------------|---------------------------|------------------------------|-------|--|------|------|------|------|-----|-----|
|  |                  |        |             |                              |                                |                           | Tensile                      | Yield | 100  | 150  | 200  | 250  | 300  | 350 | 400 |
| <b>Aluminum Alloys — Forgings and Fittings [Note (5)] (Cont'd)</b> |                  |        |             |                              |                                |                           |                              |       |  |      |      |      |      |     |     |
| B361   | 23               | WP6061 | T6          | ...                          | (14) (20)<br>(27) (28)<br>(41) | -452                      | 38                           | 35    | 12.7   | 12.7 | 12.7 | 12.1 | 10.6 | 7.9 | 5.6 |
| B361   | 23               | WP6061 | T4, T6 wld. | ...                          | (19) (20)<br>(27) (41)         | -452                      | 24                           | ...   | 8.0  | 8.0  | 8.0  | 7.9  | 7.4  | 6.1 | 4.3 |
| B361   | 23               | WP6063 | T4          | ...                          | (14) (20)<br>(27) (28)         | -452                      | 18                           | 9     | 6.0  | 6.0  | 6.0  | 6.0  | 6.0  | 3.4 | 2.0 |
| B361   | 23               | WP6063 | T6          | ...                          | (14) (20)<br>(27) (28)         | -452                      | 30                           | 25    | 10.0   | 10.0 | 9.8  | 9.0  | 6.6  | 3.4 | 2.0 |
| B361   | 23               | WP6063 | T4, T6 wld. | ...                          | (20) (27)                      | -452                      | 17                           | ...   | 5.7  | 5.7  | 5.7  | 5.6  | 5.2  | 3.0 | 2.0 |
| <b>Aluminum Alloys — Castings [Note (5)]</b>                       |                  |        |             |                              |                                |                           |                              |       |  |      |      |      |      |     |     |
| B26  | ...              | 443.0  | F           | ...                          | (11) (32)                      | -452                      | 17                           | 7     | 4.7  | 4.7  | 4.7  | 4.7  | 4.7  | 4.7 | 3.5 |
| B26  | ...              | 356.0  | T6          | ...                          | (11) (32)                      | -452                      | 30                           | 20    | 10.0   | 10.0 | 10.0 | 8.4  | ...  | ... | ... |
| B26  | ...              | 356.0  | T71         | ...                          | (11) (32)                      | -452                      | 25                           | 18    | 8.3  | 8.3  | 8.3  | 8.1  | 7.3  | 5.5 | 2.4 |



**Table IX-1A**  
**Basic Allowable Stresses in Tension for Metal Piping Materials (Cont'd)**

## GENERAL NOTES:

- (a) The allowable stress values, P-Number assignments, and minimum temperatures in this table, together with the referenced Notes and single or double bars, are requirements of this Code.
- (b) [Tables IX-5A, IX-5B, and IX-5C](#) provide for use in designing carbon steel and low and intermediate alloy piping and pipeline systems that will have a design temperature within the hydrogen embrittlement range of the selected material [recommended lowest service temperature up to 150°C (300°F)].
- (c) Notes (1) through (9), (52), and (53) are referenced in table headings, and in headings for material type and product form; Notes (9), (10), and following are referenced in the Notes column for specific materials. Notes marked with an asterisk (\*) restate requirements found in the text of the Code.
- (d) At this time, metric equivalents have not been provided in [Appendix IX](#)'s tables. To convert stress values in [Table IX-1A](#) to MPa at a given temperature in degrees Celsius, determine the equivalent temperature in degrees Fahrenheit and interpolate to calculate the stress value in ksi at the given temperature. Multiply that value by 6.895 to determine basic allowable stress,  $S$ , in MPa at the given temperature.

## NOTES:

- (1) \*See ASME BPVC, Section IX for description of P-Number groupings. P-Numbers are indicated by number or by a number followed by a letter (e.g., 8 or 5B).
- (2) \*The minimum temperature shown is that design minimum temperature for which the material is normally suitable without impact testing other than that required by the material specification. However, the use of a material at a design minimum temperature below -20°F (-29°C) is established by rules elsewhere in this Code, including [para. GR-2.1.2\(b\)](#) and other impact test requirements. For carbon steels with a letter designation in the Min. Temp. column, see [para. GR-2.1.2\(b\)\(2\)](#), and the applicable curve and Notes in [Figure GR-2.1.2-1](#).
- (3) \*The stress values are basic allowable stresses in tension in accordance with [para. IP-2.2.6\(a\)](#). For pressure design, the stress values are multiplied by the appropriate quality factor,  $E$  ( $E_c$  from [Table IX-2](#) or  $E_f$  from [Table IX-3A](#)). Stress values in shear and bearing are stated in [para. IP-2.2.6\(b\)](#); those in compression in [para. IP-2.2.6\(c\)](#).
- (4) Furnace butt welds are prohibited.
- (5) \*The quality factors for castings,  $E_c$ , in [Table IX-2](#) are basic factors in accordance with [para. IP-2.2.8\(b\)](#). The quality factors for longitudinal weld joints,  $E_f$ , in [Tables IX-3A and IX-3B](#) are basic factors in accordance with [para. IP-2.2.9\(a\)](#). See [paras. IP-2.2.8\(c\) and IP-2.2.9\(b\)](#) for enhancement of quality factors. See also [para. IP-2.2.6\(a\)](#), footnote 1.
- (6) The stress values for austenitic stainless steels in this table may not be applicable if the material has been given a final heat treatment other than that required by the material specification or by reference to [Note \(25\)](#) or [\(26\)](#).
- (7) \*Stress values printed in *italics* exceed two-thirds of the expected yield strength at temperature. Stress values in **boldface** are equal to 90% of expected yield strength at temperature. See [paras. IP-2.2.7\(b\)\(3\) and \(c\)](#).
- (8) For copper and copper alloy materials, the following symbols are used in the Temper column:
  - (a) O25 = hot rolled, annealed
  - (b) O50 = light annealed
  - (c) O60 = soft annealed
  - (d) O61 = annealed
  - (e) WO50 = welded, annealed
  - (f) WO61 = welded, fully finished, annealed
  - (g) H55 = light drawn
  - (h) H58 = drawn, general purpose
  - (i) H80 = hard drawn
- (9) For nickel and nickel alloy materials, the following abbreviations are used in the Temper column:
  - (a) Ann. = annealed
  - (b) forg. = forged
  - (c) H.R. = hot rolled
  - (d) H.W. = hot worked
  - (e) plt. = plate
  - (f) r. = rolled
  - (g) rel. = relieved
  - (h) str. = stress
- (10) \*There are restrictions on the use of this material in the text of the Code as follows:
  - (a) Temperature limits are -20°F to 366°F (-29°C to 186°C).
  - (b) Pipe shall be safeguarded when used outside the temperature limits in (a) above.
  - (c) See [Table GR-2.1.2-1](#).
- (11) \*For pressure-temperature ratings of components made in accordance with standards listed in [Table IP-8.1.1-1](#), see [para. IP-8.2.1](#). Stress values in [Mandatory Appendix IX](#) may be used to calculate ratings for unlisted components, and special ratings for listed components, as permitted by [para. IP-3.8](#).
- (12) \*This casting quality factor is applicable only when proper supplementary examination has been performed (see [para. IP-2.2.8](#)).
- (13) \*For use under this Code, radiography shall be performed after heat treatment.
- (14) Properties of this material vary with thickness or size. Stress values are based on minimum properties for the thickness listed.
- (15) For use in Code piping at the stated stress values, the required minimum tensile and yield properties must be verified by tensile test. If such tests are not required by the material specification, they shall be specified in the purchase order.

**Table IX-1A**  
**Basic Allowable Stresses in Tension for Metal Piping Materials (Cont'd)**

## NOTES: (Cont'd)

- (16) For pipe sizes  $\geq$  NPS 8 (DN 200) with wall thicknesses  $\geq$  Sch. 140, the specified minimum tensile strength is 70 ksi (483 MPa).
- (17) For material thickness above 5 in. (127 mm), the specified minimum tensile strength is 70 ksi (483 MPa).
- (18) For material thickness above 5 in. (127 mm), the specified minimum tensile strength is 65 ksi (448 MPa).
- (19) The minimum tensile strength for weld (qualification) and stress values shown shall be multiplied by 0.90 for pipe having an outside diameter less than 2 in. (51 mm) and a  $D/t$  value less than 15. This requirement may be waived if it can be shown that the welding procedure to be used will consistently produce welds that meet the listed minimum tensile strength of 24 ksi (165 MPa).
- (20) Lightweight aluminum alloy welded fittings conforming to dimensions in MSS SP-43 shall have full penetration welds.
- (21) Yield strength is not stated in the material specification. The value shown is based on yield strengths of materials with similar characteristics.
- (22) This unstabilized grade of stainless steel increasingly tends to precipitate intergranular carbides as the carbon content increases above 0.03%. Also see [para. GR-2.1.4\(b\)\(3\)](#).
- (23) For temperatures above 800°F (427°C), these stress values apply only when the carbon content is 0.04% or higher.
- (24) For temperatures above 1,000°F (538°C), these stress values apply only when the carbon content is 0.04% or higher.
- (25) For temperatures above 1,000°F (538°C), these stress values may be used only if the material has been heat treated at a temperature of 2,000°F (1 093°C) minimum.
- (26) For temperatures above 1,000°F (538°C), these stress values may be used only if the material has been heat treated by heating to a minimum temperature of 1,900°F (1 038°C) and quenching in water or rapidly cooling by other means.
- (27) Stress values shown are for the lowest-strength base material permitted by the specification to be used in the manufacture of this grade of fitting. If a higher-strength base material is used, the higher stress values for that material may be used in design.
- (28) For welded construction with work-hardened grades, use the stress values for annealed material; for welded construction with precipitation-hardened grades, use the special stress values for welded construction given in the table.
- (29) If material is welded, brazed, or soldered, the allowable stress values for the annealed condition shall be used.
- (30) The specification permits this material to be furnished without solution heat treatment or with other than a solution heat treatment. When the material has not been solution heat treated, the minimum temperature shall be  $-20^{\circ}\text{F}$  ( $-29^{\circ}\text{C}$ ) unless the material is impact tested per [para. GR-2.1.3](#).
- (31) Impact requirements for seamless fittings shall be governed by those listed in this table for the particular base material specification in the grades permitted (ASTM A312, A240, and A182). When ASTM A276 materials are used in the manufacture of these fittings, the Notes, minimum temperatures, and allowable stresses for comparable grades of ASTM A240 materials shall apply.
- (32) \*The stress values given for this material are not applicable when either welding or thermal cutting is employed [see [para. GR-2.1.4\(b\)\(5\)](#)].
- (33) Stress values shown are applicable for "die" forgings only.
- (34) This material may require special consideration for welding qualification. See the ASME BPVC, Section IX, QW/QB-422. For use in this Code, a qualified WPS is required for each strength level of material.
- (35) The maximum operating temperature is arbitrarily set at 500°F (260°C) because hard temper adversely affects design stress in the creep rupture temperature ranges.
- (36) Pipe produced to this specification is not intended for high temperature service. The stress values apply to either non-expanded or cold-expanded material in the as-rolled, normalized, or normalized and tempered condition.
- (37) Because of thermal instability, this material is not recommended for service above 800°F (427°C).
- (38) Conversion of carbides to graphite may occur after prolonged exposure to temperatures above 800°F (427°C). See [para. GR-2.1.4\(b\)\(2\)\(a\)](#).
- (39) Conversion of carbides to graphite may occur after prolonged exposure to temperatures above 875°F (468°C). See [para. GR-2.1.4\(b\)\(2\)\(b\)](#).
- (40) For temperatures above 900°F (482°C), consider the advantages of killed steel. See [para. GR-2.1.4\(b\)\(2\)\(c\)](#).
- (41) For stress-relieved tempers (T451, T4510, T4511, T651, T6510, and T6511), stress values for material in the listed temper shall be used.
- (42) DELETED
- (43) Stress values shown are 90% of those for the corresponding core material.
- (44) For use under this Code, the heat treatment requirements for pipe manufactured to ASTM A671, A672, and A691 shall be as required by [para. GR-3.6](#) for the particular material being used.
- (45) The tension test specimen from plate  $\frac{1}{2}$  in. (12.7 mm) and thicker is machined from the core and does not include the cladding alloy; therefore, the stress values listed are those for materials less than  $\frac{1}{2}$  in. (12.7 mm).
- (46) This material may be used only in nonpressure applications.
- (47) These materials are normally microalloyed with Cb, V, and/or Ti. Supplemental specifications agreed to by manufacturer and purchaser commonly establish chemistry more restrictive than the base specification, as well as plate rolling specifications and requirements for weldability (i.e., C-equivalent) and toughness.
- (48) For service temperature above 850°F (454°C), weld metal shall have a carbon content above 0.05%.
- (49) Stress values shown are for materials in the normalized and tempered condition, or when the heat treatment is unknown. If material is annealed, use the following value above 950°F: at 1,000°F, 8.0 ksi.
- (50) The pipe grades listed below, produced in accordance with CSA Z245.1, shall be considered as equivalents to API 5L and treated as listed materials.

**Table IX-1A**  
**Basic Allowable Stresses in Tension for Metal Piping Materials (Cont'd)**

NOTES: (Cont'd)

| API 5L | CSA Z245.1 |
|--------|------------|
| A25    | 172        |
| A      | 207        |
| B      | 241        |
| X42    | 290        |
| X52    | 359        |
| X56    | 386        |
| X60    | 414        |
| X65    | 448        |
| X70    | 483        |
| X80    | 550        |

(51) For nonpressure applications only.

(52) Brass and bronze castings that are polymer impregnated should not be used.

(53) Alloys with constituents that melt at temperatures less than 120% of a laminar hydrogen flame temperature should be avoided.

(54) Austenitic grades only.

**Table IX-1B**  
**SMYS for Steel Pipe Commonly Used in Pipeline Systems**

(23)

| Specification No. | Grade      | Type<br>[Note (1)] | SMYS         |     |
|-------------------|------------|--------------------|--------------|-----|
|                   |            |                    | psi          | MPa |
| API 5L [Note (2)] | A25        | ERW, S             | 25,000       | 172 |
|                   | A          | ERW, S, DSA        | 30,000       | 207 |
|                   | B          | ERW, S, DSA        | 35,000       | 241 |
|                   | X42        | ERW, S, DSA        | 42,000       | 290 |
|                   | X52        | ERW, S, DSA        | 52,000       | 359 |
| API 5L [Note (2)] | X56        | ERW, S, DSA        | 56,000       | 386 |
|                   | X60        | ERW, S, DSA        | 60,000       | 414 |
|                   | X65        | ERW, S, DSA        | 65,000       | 448 |
|                   | X70        | ERW, S, DSA        | 70,000       | 483 |
|                   | X80        | ERW, S, DSA        | 80,000       | 552 |
| ASTM A53          | A          | ERW, S             | 30,000       | 207 |
|                   | B          | ERW, S             | 35,000       | 241 |
| ASTM A106         | A          | S                  | 30,000       | 207 |
|                   | B          | S                  | 35,000       | 241 |
|                   | C          | S                  | 40,000       | 276 |
| ASTM A134         | ...        | EFW                | See Note (3) |     |
| ASTM A135         | A          | EFW                | 30,000       | 207 |
|                   | B          | EFW                | 35,000       | 241 |
| ASTM A139         | A          | EFW                | 30,000       | 207 |
|                   | B          | EFW                | 35,000       | 241 |
|                   | C          | EFW                | 42,000       | 290 |
|                   | D          | EFW                | 46,000       | 317 |
|                   | E          | EFW                | 52,000       | 359 |
| ASTM A333         | 1          | S, ERW             | 30,000       | 207 |
|                   | 6          | S, ERW             | 35,000       | 241 |
| ASTM A381         | Class Y-35 | DSA                | 35,000       | 241 |
|                   | Class Y-42 | DSA                | 42,000       | 291 |
|                   | Class Y-46 | DSA                | 46,000       | 317 |
|                   | Class Y-48 | DSA                | 48,000       | 331 |
| ASTM A381         | Class Y-50 | DSA                | 50,000       | 345 |
|                   | Class Y-52 | DSA                | 52,000       | 359 |
|                   | Class Y-56 | DSA                | 56,000       | 386 |
|                   | Class Y-60 | DSA                | 60,000       | 414 |
|                   | Class Y-65 | DSA                | 65,000       | 448 |

GENERAL NOTE: This table is not complete. For the minimum specified yield strength of other grades and grades in other approved specifications, refer to the particular specification.

## NOTES:

(1) The following abbreviations are used: DSA, double submerged-arc welded; EFW, electric fusion welded; ERW, electric resistance welded; FW, flash welded; and S, seamless.

(2) Intermediate grades are available in API 5L. Furnace butt welds are prohibited.

**Table IX-1B**  
**SMYS for Steel Pipe Commonly Used in Pipeline Systems (Cont'd)**

NOTES: (Cont'd)

(3) Spiral welded material prohibited.

**Table IX-2**  
**Basic Casting Quality Factors,  $E_c$**

| Spec. No.                               | Description                              | $E_c$ [Note (1)] | Notes    |
|---|--|------------------|----------|
| <b>Carbon Steel</b>                     |  |                  |          |
| A216                                    | Carbon steel castings                    | 0.80             | (2), (3) |
| A352                                    | Ferritic steel castings                  | 0.80             | (2), (3) |
| <b>Low and Intermediate Alloy Steel</b> |  |                  |          |
| A217                                    | Martensitic stainless and alloy castings | 0.80             | (2), (3) |
| A352                                    | Ferritic steel castings                  | 0.80             | (2), (3) |
| A426                                    | Centrifugally cast pipe                  | 1.00             | (4)      |
| <b>Stainless Steel</b>                  |  |                  |          |
| A351                                    | Austenitic steel castings                | 0.80             | (2), (3) |
| A451                                    | Centrifugally cast pipe                  | 0.90             | (3), (4) |
| <b>Copper and Copper Alloy</b>          |  |                  |          |
| B61                                     | Steam bronze castings                    | 0.80             | (2), (3) |
| B62                                     | Composition bronze castings              | 0.80             | (2), (3) |
| B148                                    | Al-bronze and Si-Al-bronze castings      | 0.80             | (2), (3) |
| B584                                    | Copper alloy castings                    | 0.80             | (2), (3) |
| <b>Aluminum Alloy</b>                   |  |                  |          |
| B26, temper F                           | Aluminum alloy castings                  | 1.00             | (2), (4) |
| B26, temper T6                          | Aluminum alloy castings                  | 0.80             | (2), (3) |
| B26, temper T71                         | Aluminum alloy castings                  | 0.80             | (2), (3) |

GENERAL NOTES:

- (a) These quality factors are determined in accordance with [para. IP-2.2.8\(b\)](#). See also [para. IP-2.2.8\(c\)](#) and [Table IP-2.2.8-1](#) for increased quality factors applicable in special cases.
- (b) Specifications are ASTM.

NOTES:

- (1) The quality factors for castings,  $E_c$ , in [Table IX-2](#) are basic factors in accordance with [para. IP-2.2.8\(b\)](#). The quality factors for longitudinal weld joints,  $E_j$ , in [Tables IX-3A](#) and [IX-3B](#) are basic factors in accordance with [para. IP-2.2.9\(a\)](#). See [paras. IP-2.2.8\(c\)](#) and [IP-2.2.9\(b\)](#) for enhancement of quality factors. See also [para. IP-2.2.6\(a\)](#), footnote 1.
- (2) For pressure-temperature ratings of components made in accordance with standards listed in [Table IP-8.1.1-1](#), see [para. IP-8.2.1](#). Stress values in [Table IX-1A](#) may be used to calculate ratings for unlisted components and special ratings for listed components, as permitted by [para. IP-3.1](#).
- (3) This casting quality factor can be enhanced by supplementary examination in accordance with [para. IP-2.2.8\(c\)](#) and [Table IP-2.2.8-1](#). The higher factor from [Table IP-2.2.8-1](#) may be substituted for this factor in pressure design equations.
- (4) This casting quality factor is applicable only when proper supplementary examination has been performed (see [para. IP-2.2.8](#)).

**Table IX-3A**  
**Basic Quality Factors for Longitudinal Weld Joints in Pipes, Tubes, and Fittings,  $E_j$**

| Spec. No.                               | Class              | Description   | $E_j$ | Notes |
|---|--------------------|---|-------|-------|
| <b>Carbon Steel</b>                     |                    |   |       |       |
| API 5L                                  | ...                | Seamless pipe   | 1.00  | ...   |
|   |                    | Electric resistance welded pipe                                   | 1.00  | ...   |
|   |                    | Electric fusion welded pipe, double butt, straight or spiral seam | 0.95  | ...   |
| A53                                     | Type S             | Seamless pipe   | 1.00  | ...   |
|   | Type E             | Electric resistance welded pipe                                   | 1.00  | ...   |
| A105                                    | ...                | Forgings and fittings   | 1.00  | (1)   |
| A106                                    | ...                | Seamless pipe   | 1.00  | ...   |
| A135                                    | ...                | Electric resistance welded pipe                                   | 1.00  | ...   |
| A139                                    | ...                | Electric fusion welded pipe, straight or spiral seam              | 0.80  | ...   |
| A179                                    | ...                | Seamless tube   | 1.00  | ...   |
| A181                                    | ...                | Forgings and fittings   | 1.00  | (1)   |
| A234                                    | ...                | Seamless and welded fittings                                      | 1.00  | (2)   |
| A333                                    | ...                | Seamless pipe   | 1.00  | ...   |
|   |                    | Electric resistance welded pipe                                   | 1.00  | ...   |
| A334                                    | ...                | Seamless tube   | 1.00  | ...   |
| A350                                    | ...                | Forgings and fittings   | 1.00  | (1)   |
| A369                                    | ...                | Seamless pipe   | 1.00  | ...   |
| A381                                    | ...                | Electric fusion welded pipe, 100% radiographed                    | 1.00  | (3)   |
|   |                    | Electric fusion welded pipe, spot radiographed                    | 0.90  | (4)   |
|   |                    | Electric fusion welded pipe, as manufactured                      | 0.85  | ...   |
| A420                                    | ...                | Welded fittings, 100% radiographed                                | 1.00  | (2)   |
| A524                                    | ...                | Seamless pipe   | 1.00  | ...   |
| A587                                    | ...                | Electric resistance welded pipe                                   | 1.00  | ...   |
| A671                                    | 12, 22, 32, 42, 52 | Electric fusion welded pipe, 100% radiographed                    | 1.00  | ...   |
|   | 13, 23, 33, 43, 53 | Electric fusion welded pipe, double butt seam                     | 0.85  | ...   |
| A672                                    | 12, 22, 32, 42, 52 | Electric fusion welded pipe, 100% radiographed                    | 1.00  | ...   |
|   | 13, 23, 33, 43, 53 | Electric fusion welded pipe, double butt seam                     | 0.85  | ...   |
| A691                                    | 12, 22, 32, 42, 52 | Electric fusion welded pipe, 100% radiographed                    | 1.00  | ...   |
|   | 13, 23, 33, 43, 53 | Electric fusion welded pipe, double butt seam                     | 0.85  | ...   |
| <b>Low and Intermediate Alloy Steel</b> |                    |   |       |       |
| A182                                    | ...                | Forgings and fittings   | 1.00  | (1)   |
| A234                                    | ...                | Seamless and welded fittings                                      | 1.00  | (2)   |
| A333                                    | ...                | Seamless pipe   | 1.00  | ...   |
|   |                    | Electric resistance welded pipe                                   | 1.00  | ...   |
| A334                                    | ...                | Seamless tube   | 1.00  | ...   |
| A335                                    | ...                | Seamless pipe   | 1.00  | ...   |
| A350                                    | ...                | Forgings and fittings   | 1.00  | ...   |
| A369                                    | ...                | Seamless pipe   | 1.00  | ...   |
| A420                                    | ...                | Welded fittings, 100% radiographed                                | 1.00  | (2)   |

**Table IX-3A**  
**Basic Quality Factors for Longitudinal Weld Joints in Pipes, Tubes, and Fittings,  $E_j$  (Cont'd)**

| Spec. No.  | Class              | Description                                    | $E_j$ | Notes |
|--|--------------------|--|-------|-------|
| <b>Low and Intermediate Alloy Steel (Cont'd)</b> |                    |  |       |       |
| A671   | 12, 22, 32, 42, 52 | Electric fusion welded pipe, 100% radiographed | 1.00  | ...   |
|  | 13, 23, 33, 43, 53 | Electric fusion welded pipe, double butt seam  | 0.85  | ...   |
| A672   | 12, 22, 32, 42, 52 | Electric fusion welded pipe, 100% radiographed | 1.00  | ...   |
|  | 13, 23, 33, 43, 53 | Electric fusion welded pipe, double butt seam  | 0.85  | ...   |
| A691   | 12, 22, 32, 42, 52 | Electric fusion welded pipe, 100% radiographed | 1.00  | ...   |
|  | 13, 23, 33, 43, 53 | Electric fusion welded pipe, double butt seam  | 0.85  | ...   |
| <b>Stainless Steel</b>                           |                    |  |       |       |
| A182   | ...                | Forgings and fittings                          | 1.00  | ...   |
| A269   | ...                | Seamless tube                                  | 1.00  | ...   |
|  |                    | Electric fusion welded tube, double butt seam  | 0.85  | ...   |
|  |                    | Electric fusion welded tube, single butt seam  | 0.80  | ...   |
| A312   | ...                | Seamless tube                                  | 1.00  | ...   |
|  |                    | Electric fusion welded tube, double butt seam  | 0.85  | ...   |
|  |                    | Electric fusion welded tube, single butt seam  | 0.80  | ...   |
| A358   | 1, 3, 4            | Electric fusion welded pipe, 100% radiographed | 1.00  | ...   |
|  | 5                  | Electric fusion welded pipe, spot radiographed | 0.90  | ...   |
|  | 2                  | Electric fusion welded pipe, double butt seam  | 0.85  | ...   |
| A376   | ...                | Seamless pipe                                  | 1.00  | ...   |
| A403   | ...                | Seamless fittings                              | 1.00  | ...   |
|  |                    | Welded fitting, 100% radiographed              | 1.00  | (2)   |
|  |                    | Welded fitting, double butt seam               | 0.85  | ...   |
|  |                    | Welded fitting, single butt seam               | 0.80  | ...   |
| A409   | ...                | Electric fusion welded pipe, double butt seam  | 0.85  | ...   |
|  |                    | Electric fusion welded pipe, single butt seam  | 0.80  | ...   |
| <b>Copper and Copper Alloy</b>                   |                    |  |       |       |
| B42  | ...                | Seamless pipe                                  | 1.00  | ...   |
| B43  | ...                | Seamless pipe                                  | 1.00  | ...   |
| B68  | ...                | Seamless tube                                  | 1.00  | ...   |
| B75  | ...                | Seamless tube                                  | 1.00  | ...   |
| B88  | ...                | Seamless water tube                            | 1.00  | ...   |
| B280   | ...                | Seamless tube                                  | 1.00  | ...   |
| B466   | ...                | Seamless pipe and tube                         | 1.00  | ...   |
| B467   | ...                | Electric resistance welded pipe                | 1.00  | ...   |
|  |                    | Electric fusion welded pipe, double butt seam  | 0.85  | ...   |
|  |                    | Electric fusion welded pipe, single butt seam  | 0.80  | ...   |
| <b>Nickel and Nickel Alloy</b>                   |                    |  |       |       |
| B165   | ...                | Seamless pipe and tube                         | 1.00  | ...   |
| B725   | ...                | Electric fusion welded pipe, double butt seam  | 0.85  | ...   |



**Table IX-3A**  
**Basic Quality Factors for Longitudinal Weld Joints in Pipes, Tubes, and Fittings,  $E_j$  (Cont'd)**

| Spec. No.             | Class | Description                           | $E_j$ | Notes    |
|-----------------------|-------|---------------------------------------|-------|----------|
| <b>Aluminum Alloy</b> |       |                                       |       |          |
| B210                  | ...   | Seamless tube                         | 1.00  | ...      |
| B241                  | ...   | Seamless pipe and tube                | 1.00  | ...      |
| B247                  | ...   | Forgings and fittings                 | 1.00  | (1)      |
| B345                  | ...   | Seamless pipe and tube                | 1.00  | ...      |
| B361                  | ...   | Seamless fittings                     | 1.00  | ...      |
|                       |       | Welded fittings, 100% radiograph      | 1.00  | (3), (5) |
|                       |       | Welded fittings, double butt          | 0.85  | (5)      |
|                       |       | Welded fittings, single butt          | 0.80  | (5)      |
| B547                  | ...   | Welded pipe and tube, 100% radiograph | 1.00  | ...      |
|                       |       | Welded pipe, double butt seam         | 0.85  | ...      |
|                       |       | Welded pipe, single butt seam         | 0.80  | ...      |

## GENERAL NOTES:

- (a) These quality factors are determined in accordance with [para. IP-2.2.9\(a\)](#). See also [para. IP-2.2.9\(b\)](#) and [Table IP-2.2.9-1](#) for increased quality factors applicable in special cases.
- (b) Specifications, except API 5L, are ASTM.

## NOTES:

- (1) For pressure-temperature ratings of components made in accordance with standards listed in [Table IP-8.1.1-1](#), see [para. IP-8.2.1](#). Stress values in [Table IX-1A](#) may be used to calculate ratings for unlisted components and special ratings for listed components, as permitted by [para. IP-3.1](#).
- (2) An  $E_j$  factor of 1.00 may be applied only if all welds, including welds in the base material, have passed 100% radiographic examination. Substitution of ultrasonic examination for radiography is not permitted for the purpose of obtaining an  $E_j$  of 1.00.
- (3) This specification does not include requirements for 100% radiographic inspection. If this higher joint factor is to be used, the material shall be purchased to the special requirements of [Table IP-10.4.3-1](#) for longitudinal butt welds with 100% radiography in accordance with [Table IP-2.2.9-1](#).
- (4) This specification includes requirements for random radiographic inspection for mill quality control. If the 0.90 joint factor is to be used, the welds shall meet the requirements of [Table IP-10.4.3-1](#) for longitudinal butt welds with spot radiography in accordance with [Table IP-2.2.9-1](#). This shall be a matter of special agreement between purchaser and manufacturer.
- (5) Lightweight aluminum alloy welded fittings conforming to dimensions in MSS SP-43 shall have full penetration welds.

**Table IX-3B**  
**Longitudinal Joints Factors for Pipeline Materials**

| <b>Spec. No.</b> | <b>Pipe Class</b>           | <b>E Factor</b> |
|------------------|-----------------------------|-----------------|
| API 5L           | Seamless                    | 1.00            |
|                  | Electric resistance welded  | 1.00            |
|                  | Electric flash welded       | 1.00            |
|                  | Double submerged arc welded | 1.00            |
| ASTM A53         | Seamless                    | 1.00            |
|                  | Electric resistance welded  | 1.00            |
| ASTM A106        | Seamless                    | 1.00            |
| ASTM A134        | Electric fusion arc welded  | 0.80            |
| ASTM A135        | Electric resistance welded  | 1.00            |
| ASTM A139        | Electric fusion welded      | 0.80            |
| ASTM A333        | Seamless                    | 1.00            |
|                  | Electric resistance welded  | 1.00            |
| ASTM A381        | Double submerged arc welded | 1.00            |
| ASTM A671        | Electric fusion welded      |                 |
|                  | Classes 13, 23, 33, 43, 53  | 0.80            |
|                  | Classes 12, 22, 32, 42, 52  | 1.00            |
| ASTM A672        | Electric fusion welded      |                 |
|                  | Classes 13, 23, 33, 43, 53  | 0.80            |
|                  | Classes 12, 22, 32, 42, 52  | 1.00            |

TABLE STARTS ON NEXT PAGE

(23)

**Table IX-4**  
**Design Stress Values for Bolting Materials**

Specifications Are ASTM Unless Otherwise Indicated

| Material               | Spec. No. | Grade         | Size Range, Diam., in. | Notes    | Min. Temp., °F [Note (1)] | Specified Min. Strength, ksi |       | Design Stress, ksi [Note (2)], at Metal Temperature, °F |      |      |      |      |
|------------------------|-----------|---------------|------------------------|----------|---------------------------|------------------------------|-------|---|------|------|------|------|
|                        |           |               |                        |          |                           | Tensile                      | Yield | Min. Temp. to 100                                       | 200  | 300  | 400  | 500  |
| <b>Carbon Steel</b>    |           |               |                        |          |                           |                              |       |   |      |      |      |      |
| ...                    | A675      | 45            | ...                    | ...      | -20                       | 45                           | 22.5  | 11.2  | 11.2 | 11.2 | 11.2 | 11.2 |
| ...                    | A675      | 50            | ...                    | ...      | -20                       | 50                           | 25    | 12.5  | 12.5 | 12.5 | 12.5 | 12.5 |
| ...                    | A675      | 55            | ...                    | ...      | -20                       | 55                           | 27.5  | 13.7  | 13.7 | 13.7 | 13.7 | 13.7 |
| ...                    | A307      | B             | ...                    | ...      | -20                       | 60                           | ...   | 13.7  | 13.7 | 13.7 | 13.7 | 13.7 |
| ...                    | A675      | 60            | ...                    | ...      | -20                       | 60                           | 30    | 15.0  | 15.0 | 15.0 | 15.0 | 15.0 |
| ...                    | A675      | 65            | ...                    | ...      | -20                       | 65                           | 32.5  | 16.2  | 16.2 | 16.2 | 16.2 | 16.2 |
| ...                    | A675      | 70            | ...                    | ...      | -20                       | 70                           | 35    | 17.5  | 17.5 | 17.5 | 17.5 | 17.5 |
| ...                    | F3125     | ...           | ...                    | ...      | -20                       | 105                          | 81    | 19.3  | 19.3 | 19.3 | 19.3 | 19.3 |
| ...                    | A675      | 80            | ...                    | ...      | -20                       | 80                           | 40    | 20.0  | 20.0 | 20.0 | 20.0 | 20.0 |
| Nuts                   | A194      | 1             | ...                    | (10)     | -20                       | ...                          | ...   | ...   | ...  | ...  | ...  | ...  |
| Nuts                   | A194      | 2, 2H         | ...                    | (10)     | -55                       | ...                          | ...   | ...   | ...  | ...  | ...  | ...  |
| ...                    | A194      | 2HM           | ...                    | (10)     | -55                       | ...                          | ...   | ...   | ...  | ...  | ...  | ...  |
| Nuts                   | A563      | A, hvy. hex.  | ...                    | (10b)    | -20                       | ...                          | ...   | ...   | ...  | ...  | ...  | ...  |
| <b>Alloy Steel</b>     |           |               |                        |          |                           |                              |       |   |      |      |      |      |
| Cr-0.2Mo               | A193      | B7M           | ≤4                     | ...      | -55                       | 100                          | 80    | 20.0  | 20.0 | 20.0 | 20.0 | 20.0 |
| Cr-0.20Mo              | A320      | L7M           | ≤2½                    | ...      | -100                      | 100                          | 80    | 20.0  | 20.0 | 20.0 | 20.0 | 20.0 |
| 5Cr                    | A193      | B5            | ≤4                     | (6)      | -20                       | 100                          | 80    | 20.0  | 20.0 | 20.0 | 20.0 | 20.0 |
| Cr-Mo-V                | A193      | B16           | >2½, ≤4                | (6)      | -20                       | 110                          | 95    | 22.0  | 22.0 | 22.0 | 22.0 | 22.0 |
| ...                    | A354      | BC            | ...                    | (6)      | 0                         | 115                          | 99    | 23.0  | 23.0 | 23.0 | 23.0 | 23.0 |
| Cr-Mo                  | A193      | B7            | >2½, ≤4                | (6)      | -40                       | 115                          | 95    | 23.0  | 23.0 | 23.0 | 23.0 | 23.0 |
| Ni-Cr-Mo               | A320      | L43           | ≤4                     | (6)      | -150                      | 125                          | 105   | 25.0  | 25.0 | 25.0 | 25.0 | 25.0 |
| Cr-Mo                  | A320      | L7            | ≤2½                    | (6)      | -150                      | 125                          | 105   | 25.0  | 25.0 | 25.0 | 25.0 | 25.0 |
| Cr-Mo                  | A320      | L7A, L7B, L7C | ≤2½                    | (6)      | -150                      | 125                          | 105   | 25.0  | 25.0 | 25.0 | 25.0 | 25.0 |
| Cr-Mo                  | A193      | B7            | ≤2½                    | ...      | -55                       | 125                          | 105   | 25.0  | 25.0 | 25.0 | 25.0 | 25.0 |
| Cr-Mo-V                | A193      | B16           | ≤2½                    | (6)      | -20                       | 125                          | 105   | 25.0  | 25.0 | 25.0 | 25.0 | 25.0 |
| ...                    | A354      | BD            | ≤2½                    | (6)      | -20                       | 150                          | 130   | 30.0  | 30.0 | 30.0 | 30.0 | 30.0 |
| 5Cr nuts               | A194      | 3             | ...                    | (10)     | -20                       | ...                          | ...   | ...   | ...  | ...  | ...  | ...  |
| Cr-Mo nuts             | A194      | 4             | ...                    | (10)     | -150                      | ...                          | ...   | ...   | ...  | ...  | ...  | ...  |
| Cr-Mo nuts             | A194      | 7             | ...                    | (10)     | -150                      | ...                          | ...   | ...   | ...  | ...  | ...  | ...  |
| Cr-Mo nuts             | A194      | 7M            | ...                    | (10)     | -150                      | ...                          | ...   | ...   | ...  | ...  | ...  | ...  |
| <b>Stainless Steel</b> |           |               |                        |          |                           |                              |       |   |      |      |      |      |
| 316                    | A193      | B8M Cl. 2     | >1¼, ≤1½               | (6) (13) | -325                      | 90                           | 50    | 18.8  | 16.2 | 16.2 | 16.2 | 16.2 |
| 316                    | A320      | B8M Cl. 2     | >1¼, ≤1½               | (6) (13) | -325                      | 90                           | 50    | 18.8  | 16.2 | 16.2 | 16.2 | 16.2 |
| 304                    | A193      | B8 Cl. 2      | >1¼, ≤1½               | (6) (13) | -325                      | 100                          | 50    | 18.8  | 17.2 | 16.0 | 15.0 | 14.0 |
| 304                    | A320      | B8 Cl. 2      | >1¼, ≤1½               | (6) (13) | -325                      | 100                          | 50    | 18.8  | 17.2 | 16.0 | 15.0 | 14.0 |
| 347                    | A193      | B8C Cl. 2     | >1¼, ≤1½               | (6) (13) | -325                      | 100                          | 50    | 18.8  | 17.8 | 16.5 | 16.3 | 16.3 |

**Table IX-4**  
**Design Stress Values for Bolting Materials**  
 Specifications Are ASTM Unless Otherwise Indicated

| Design Stress, ksi [Note (2)], at Metal Temperature, °F |      |      |      |      |      |      |      |       |               | Spec. No. |
|---|------|------|------|------|------|------|------|-------|---------------|-----------|
| 600   | 650  | 700  | 750  | 800  | 850  | 900  | 950  | 1,000 | Grade         |           |
| <b>Carbon Steel</b>                                     |      |      |      |      |      |      |      |       |               |           |
| 11.2  | 11.2 | 11.0 | 10.2 | 9.0  | 7.7  | 6.5  | ...  | ...   | 45            | A675      |
| 12.5  | 12.5 | 12.1 | 11.1 | 9.6  | 8.0  | 6.5  | ...  | ...   | 50            | A675      |
| 13.7  | 13.7 | 13.2 | 12.0 | 10.2 | 8.3  | 6.5  | ...  | ...   | 55            | A675      |
| ...   | ...  | ...  | ...  | ...  | ...  | ...  | ...  | ...   | B             | A307      |
| 15.0  | 15.0 | 14.3 | 12.9 | 10.8 | 8.6  | 6.5  | ...  | ...   | 60            | A675      |
| 16.2  | 16.2 | 15.5 | 13.8 | 11.5 | 8.9  | 6.5  | 4.5  | 2.5   | 65            | A675      |
| 17.5  | 17.5 | 16.6 | 14.7 | 12.0 | 9.2  | 6.5  | 4.5  | 2.5   | 70            | A675      |
| 19.3  | ...  | ...  | ...  | ...  | ...  | ...  | ...  | ...   | ...           | F3125     |
| 20.0  | ...  | ...  | ...  | ...  | ...  | ...  | ...  | ...   | 80            | A675      |
| ...   | ...  | ...  | ...  | ...  | ...  | ...  | ...  | ...   | 1             | A194      |
| ...   | ...  | ...  | ...  | ...  | ...  | ...  | ...  | ...   | 2, 2H         | A194      |
| ...   | ...  | ...  | ...  | ...  | ...  | ...  | ...  | ...   | 2HM           | A194      |
| ...   | ...  | ...  | ...  | ...  | ...  | ...  | ...  | ...   | A, hvy. hex.  | A563      |
| <b>Alloy Steel</b>                                      |      |      |      |      |      |      |      |       |               |           |
| 20.0  | 20.0 | 20.0 | 20.0 | 18.5 | 16.2 | 12.5 | 8.5  | 4.5   | B7M           | A193      |
| 20.0  | 20.0 | 20.0 | 20.0 | 18.5 | 16.2 | 12.5 | 8.5  | 4.5   | L7M           | A320      |
| 20.0  | 20.0 | 20.0 | 20.0 | 18.5 | 14.5 | 10.4 | 7.6  | 5.6   | B5            | A193      |
| 22.0  | 22.0 | 22.0 | 22.0 | 22.0 | 21.0 | 18.5 | 15.3 | 11.0  | B16           | A193      |
| 23.0  | 20.0 | ...  | ...  | ...  | ...  | ...  | ...  | ...   | BC            | A354      |
| 23.0  | 23.0 | 23.0 | 22.2 | 20.0 | 16.3 | 12.5 | 8.5  | 4.5   | B7            | A193      |
| 25.0  | 25.0 | 25.0 | ...  | ...  | ...  | ...  | ...  | ...   | L43           | A320      |
| 25.0  | 25.0 | 25.0 | ...  | ...  | ...  | ...  | ...  | ...   | L7            | A320      |
| 25.0  | 25.0 | ...  | ...  | ...  | ...  | ...  | ...  | ...   | L7A, L7B, L7C | A320      |
| 25.0  | 25.0 | 25.0 | 23.6 | 21.0 | 17.0 | 12.5 | 8.5  | 4.5   | B7            | A193      |
| 25.0  | 25.0 | 25.0 | 25.0 | 25.0 | 23.5 | 20.5 | 16.0 | 11.0  | B16           | A193      |
| 30.0  | 30.0 | ...  | ...  | ...  | ...  | ...  | ...  | ...   | BD            | A354      |
| ...   | ...  | ...  | ...  | ...  | ...  | ...  | ...  | ...   | 3             | A194      |
| ...   | ...  | ...  | ...  | ...  | ...  | ...  | ...  | ...   | 4             | A194      |
| ...   | ...  | ...  | ...  | ...  | ...  | ...  | ...  | ...   | 7             | A194      |
| ...   | ...  | ...  | ...  | ...  | ...  | ...  | ...  | ...   | 7M            | A194      |
| <b>Stainless Steel</b>                                  |      |      |      |      |      |      |      |       |               |           |
| 16.2  | 12.5 | 12.5 | 12.5 | 12.5 | 10.9 | 10.8 | 10.7 | 10.6  | B8M Cl. 2     | A193      |
| 16.2  | 12.5 | 12.5 | 12.5 | 12.5 | 10.9 | 10.8 | 10.7 | 10.6  | B8M Cl. 2     | A320      |
| 13.4  | 12.5 | 12.5 | 12.5 | 12.5 | 12.5 | 12.5 | 12.5 | 12.5  | B8 Cl. 2      | A193      |
| 13.4  | 12.5 | 12.5 | 12.5 | 12.5 | 12.5 | 12.5 | 12.5 | 12.5  | B8 Cl. 2      | A320      |
| 16.3  | 13.1 | 12.9 | 12.8 | 12.7 | 12.6 | 12.6 | 12.5 | 12.5  | B8C Cl. 2     | A193      |

**Table IX-4**  
**Design Stress Values for Bolting Materials (Cont'd)**

Specifications Are ASTM Unless Otherwise Indicated

| Material               | Spec. No. | Grade     | Size Range, Diam., in.             | Notes    | Min. Temp., °F [Note (1)] | Specified Min. Strength, ksi |       | Design Stress, ksi [Note (2)], at Metal Temperature, °F |      |      |      |      |
|------------------------|-----------|-----------|------------------------------------|----------|---------------------------|------------------------------|-------|---|------|------|------|------|
|                        |           |           |                                    |          |                           | Tensile                      | Yield | Min. Temp. to 100                                       | 200  | 300  | 400  | 500  |
| <b>Stainless Steel</b> |           |           |                                    |          |                           |                              |       |   |      |      |      |      |
| 347                    | A320      | B8C Cl. 2 | $>1\frac{1}{4}, \leq 1\frac{1}{2}$ | (6) (13) | -325                      | 100                          | 50    | 18.8  | 17.8 | 16.5 | 16.3 | 16.3 |
| 321                    | A193      | B8T Cl. 2 | $>1\frac{1}{4}, \leq 1\frac{1}{2}$ | (6) (13) | -325                      | 100                          | 50    | 18.8  | 16.7 | 16.3 | 16.3 | 16.3 |
| 321                    | A320      | B8T Cl. 2 | $>1\frac{1}{4}, \leq 1\frac{1}{2}$ | (6) (13) | -325                      | 100                          | 50    | 18.8  | 16.7 | 16.3 | 16.3 | 16.3 |
| 303 sol. trt.          | A320      | B8F Cl. 1 | ...                                | (6) (9)  | -325                      | 75                           | 30    | 18.8  | 13.0 | 12.0 | 10.9 | 10.0 |
| 19Cr-9Ni               | A453      | 651B      | $>3$                               | (6) (8)  | -20                       | 95                           | 50    | 19.0  | 19.0 | 19.0 | 19.0 | 19.0 |
| 19Cr-9Ni               | A453      | 651B      | $\leq 3$                           | (6) (8)  | -20                       | 95                           | 60    | 19.0  | 19.0 | 19.0 | 19.0 | 19.0 |
| 19Cr-9Ni               | A453      | 651A      | $>3$                               | (6) (8)  | -20                       | 100                          | 60    | 20.0  | 20.0 | 20.0 | 20.0 | 20.0 |
| 19Cr-9Ni               | A453      | 651A      | $\leq 3$                           | (6) (8)  | -20                       | 100                          | 70    | 20.0  | 20.0 | 20.0 | 20.0 | 20.0 |
| 316                    | A193      | B8M Cl. 2 | $>1, \leq 1\frac{1}{4}$            | (6) (13) | -325                      | 105                          | 65    | 18.8  | 16.2 | 16.2 | 16.2 | 16.2 |
| 316                    | A320      | B8M Cl. 2 | $>1, \leq 1\frac{1}{4}$            | (6) (13) | -325                      | 105                          | 65    | 18.8  | 16.2 | 16.2 | 16.2 | 16.2 |
| 347                    | A193      | B8C Cl. 2 | $>1, \leq 1\frac{1}{4}$            | (6) (13) | -325                      | 105                          | 65    | 18.8  | 17.2 | 16.0 | 15.0 | 14.0 |
| 347                    | A320      | B8C Cl. 2 | $>1, \leq 1\frac{1}{4}$            | (6) (13) | -325                      | 105                          | 65    | 18.8  | 17.2 | 16.0 | 15.0 | 14.0 |
| 304                    | A193      | B8 Cl. 2  | $>1, \leq 1\frac{1}{4}$            | (6) (13) | -325                      | 105                          | 65    | 18.8  | 16.7 | 16.3 | 16.3 | 16.3 |
| 304                    | A320      | B8 Cl. 2  | $>1, \leq 1\frac{1}{4}$            | (6) (13) | -325                      | 105                          | 65    | 18.8  | 16.7 | 16.3 | 16.3 | 16.3 |
| 321                    | A193      | B8T Cl. 2 | $>1, \leq 1\frac{1}{4}$            | (6) (13) | -325                      | 105                          | 65    | 18.8  | 17.8 | 16.5 | 16.3 | 16.3 |
| 321                    | A320      | B8T Cl. 2 | $>1, \leq 1\frac{1}{4}$            | (6) (13) | -325                      | 105                          | 65    | 18.8  | 17.8 | 16.5 | 16.3 | 16.3 |
| 321                    | A193      | B8T Cl. 1 | ...                                | (6) (7)  | -325                      | 75                           | 30    | 18.8  | 17.8 | 16.5 | 15.3 | 14.3 |
| 304                    | A320      | B8 Cl. 1  | ...                                | (6) (7)  | -325                      | 75                           | 30    | 18.8  | 16.7 | 15.0 | 13.8 | 12.9 |
| 347                    | A193      | B8C Cl. 1 | ...                                | (6) (7)  | -325                      | 75                           | 30    | 18.8  | 17.9 | 16.4 | 15.5 | 15.0 |
| 316                    | A193      | B8M Cl. 1 | ...                                | (6) (7)  | -325                      | 75                           | 30    | 18.8  | 17.7 | 15.6 | 14.3 | 13.3 |
| 316 str. hd.           | A193      | B8M Cl. 2 | $>\frac{3}{4}, \leq 1$             | (6) (13) | -325                      | 100                          | 80    | 20.0  | 20.0 | 20.0 | 20.0 | 20.0 |
| 316 str. hd.           | A320      | B8M Cl. 2 | $>\frac{3}{4}, \leq 1$             | (6) (13) | -325                      | 100                          | 80    | 20.0  | 20.0 | 20.0 | 20.0 | 20.0 |
| 347 str. hd.           | A193      | B8C Cl. 2 | $>\frac{3}{4}, \leq 1$             | (6) (13) | -325                      | 115                          | 80    | 20.0  | 17.2 | 16.0 | 15.0 | 14.0 |
| 347 str. hd.           | A320      | B8C Cl. 2 | $>\frac{3}{4}, \leq 1$             | (6) (13) | -325                      | 115                          | 80    | 20.0  | 17.2 | 16.0 | 15.0 | 14.0 |
| 304 str. hd.           | A193      | B8 Cl. 2  | $>\frac{3}{4}, \leq 1$             | (6) (13) | -325                      | 115                          | 80    | 20.0  | 20.0 | 20.0 | 20.0 | 20.0 |
| 304 str. hd.           | A320      | B8 Cl. 2  | $>\frac{3}{4}, \leq 1$             | (6) (13) | -325                      | 115                          | 80    | 20.0  | 20.0 | 20.0 | 20.0 | 20.0 |
| 321 str. hd.           | A193      | B8T Cl. 2 | $>\frac{3}{4}, \leq 1$             | (6) (13) | -325                      | 115                          | 80    | 20.0  | 20.0 | 20.0 | 20.0 | 20.0 |
| 321 str. hd.           | A320      | B8T Cl. 2 | $>\frac{3}{4}, \leq 1$             | (6) (13) | -325                      | 115                          | 80    | 20.0  | 20.0 | 20.0 | 20.0 | 20.0 |
| 12Cr                   | A437      | B4C       | ...                                | (8)      | -20                       | 115                          | 85    | 21.2  | 21.2 | 21.2 | 21.2 | 21.2 |
| 13Cr                   | A193      | B6        | $\leq 4$                           | (6) (8)  | -20                       | 110                          | 85    | 21.2  | 21.2 | 21.2 | 21.2 | 21.2 |
| 14Cr-24Ni              | A453      | 660A/B    | ...                                | (6) (8)  | -325                      | 130                          | 85    | 21.3  | 20.7 | 20.5 | 20.4 | 20.3 |
| 316 str. hd.           | A193      | B8M Cl. 2 | $\leq \frac{3}{4}$                 | (6) (13) | -325                      | 110                          | 95    | 22.0  | 22.0 | 22.0 | 22.0 | 22.0 |
| 316 str. hd.           | A320      | B8M Cl. 2 | $\leq \frac{3}{4}$                 | (6) (13) | -325                      | 110                          | 95    | 22.0  | 22.0 | 22.0 | 22.0 | 22.0 |
| 347                    | A193      | B8C Cl. 2 | $\leq \frac{3}{4}$                 | (6) (13) | -325                      | 125                          | 100   | 25.0  | 25.0 | 25.0 | 25.0 | 25.0 |
| 347                    | A320      | B8C Cl. 2 | $\leq \frac{3}{4}$                 | (6) (13) | -325                      | 125                          | 100   | 25.0  | 25.0 | 25.0 | 25.0 | 25.0 |

**Table IX-4  
Design Stress Values for Bolting Materials (Cont'd)**  
Specifications Are ASTM Unless Otherwise Indicated

| Design Stress, ksi [Note (2)], at Metal Temperature, °F |      |      |      |      |      |      |      |       |           | Spec. No. |
|---|------|------|------|------|------|------|------|-------|-----------|-----------|
| 600   | 650  | 700  | 750  | 800  | 850  | 900  | 950  | 1,000 | Grade     |           |
| <b>Stainless Steel (Cont'd)</b>                         |      |      |      |      |      |      |      |       |           |           |
| 16.3  | 13.1 | 12.9 | 12.8 | 12.7 | 12.6 | 12.6 | 12.5 | 12.5  | B8C Cl. 2 | A320      |
| 16.3  | 13.3 | 12.9 | 12.7 | 12.5 | 12.5 | 12.5 | 12.5 | 12.5  | B8T Cl. 2 | A193      |
| 16.3  | 13.3 | 12.9 | 12.7 | 12.5 | 12.5 | 12.5 | 12.5 | 12.5  | B8T Cl. 2 | A320      |
| 9.3   | 8.9  | 8.6  | 8.3  | 8.0  | ...  | ...  | ...  | ...   | B8F Cl. 1 | A320      |
| 19.0  | 19.0 | 19.0 | 19.0 | 19.0 | 19.0 | 19.0 | 18.9 | 18.2  | 651B      | A453      |
| 19.0  | 19.0 | 19.0 | 19.0 | 19.0 | 19.0 | 19.0 | 18.9 | 18.2  | 651B      | A453      |
| 20.0  | 20.0 | 20.0 | 20.0 | 20.0 | 20.0 | 20.0 | 19.8 | 19.2  | 651A      | A453      |
| 20.0  | 20.0 | 20.0 | 20.0 | 20.0 | 20.0 | 20.0 | 19.8 | 19.2  | 651A      | A453      |
| 16.2  | 16.2 | 16.2 | 16.2 | 16.2 | 10.9 | 10.8 | 10.7 | 10.6  | B8M Cl. 2 | A193      |
| 16.2  | 16.2 | 16.2 | 16.2 | 16.2 | 10.9 | 10.8 | 10.7 | 10.6  | B8M Cl. 2 | A320      |
| 13.4  | 13.1 | 12.9 | 12.8 | 12.7 | 12.6 | 12.6 | 12.5 | 12.5  | B8C Cl. 2 | A193      |
| 13.4  | 13.1 | 12.9 | 12.8 | 12.7 | 12.6 | 12.6 | 12.5 | 12.5  | B8C Cl. 2 | A320      |
| 16.3  | 16.3 | 16.3 | 16.3 | 16.3 | 16.3 | 16.3 | 16.3 | 16.3  | B8 Cl. 2  | A193      |
| 16.3  | 16.3 | 16.3 | 16.3 | 16.3 | 16.3 | 16.3 | 16.3 | 16.3  | B8 Cl. 2  | A320      |
| 16.3  | 16.3 | 16.3 | 16.3 | 16.3 | 16.3 | 16.3 | 16.3 | 16.3  | B8T Cl. 2 | A193      |
| 16.3  | 16.3 | 16.3 | 16.3 | 16.3 | 16.3 | 16.3 | 16.3 | 16.3  | B8T Cl. 2 | A320      |
| 13.5  | 13.3 | 12.9 | 12.7 | 12.5 | 12.4 | 12.3 | 12.1 | 12.1  | B8T Cl. 1 | A193      |
| 12.1  | 12.0 | 11.8 | 11.5 | 11.2 | 11.0 | 10.8 | 10.6 | 10.4  | B8 Cl. 1  | A320      |
| 14.3  | 14.1 | 13.8 | 13.7 | 13.6 | 13.5 | 13.5 | 13.4 | 13.4  | B8C Cl. 1 | A193      |
| 12.6  | 12.3 | 12.1 | 11.9 | 11.7 | 11.6 | 11.5 | 11.4 | 11.3  | B8M Cl. 1 | A193      |
| 20.0  | 20.0 | 20.0 | 20.0 | 20.0 | 10.9 | 10.8 | 10.7 | 10.6  | B8M Cl. 2 | A193      |
| 20.0  | 20.0 | 20.0 | 20.0 | 20.0 | 10.9 | 10.8 | 10.7 | 10.6  | B8M Cl. 2 | A320      |
| 13.4  | 13.1 | 12.9 | 12.8 | 12.7 | 12.6 | 12.6 | 12.5 | 12.5  | B8C Cl. 2 | A193      |
| 13.4  | 13.1 | 12.9 | 12.8 | 12.7 | 12.6 | 12.6 | 12.5 | 12.5  | B8C Cl. 2 | A320      |
| 20.0  | 20.0 | 20.0 | 20.0 | 20.0 | 20.0 | 20.0 | 20.0 | 20.0  | B8 Cl. 2  | A193      |
| 20.0  | 20.0 | 20.0 | 20.0 | 20.0 | 20.0 | 20.0 | 20.0 | 20.0  | B8 Cl. 2  | A320      |
| 20.0  | 20.0 | 20.0 | 20.0 | 20.0 | 20.0 | 20.0 | 20.0 | 20.0  | B8T Cl. 2 | A193      |
| 20.0  | 20.0 | 20.0 | 20.0 | 20.0 | 20.0 | 20.0 | 20.0 | 20.0  | B8T Cl. 2 | A320      |
| 21.2  | 21.2 | 21.2 | ...  | ...  | ...  | ...  | ...  | ...   | B4C       | A437      |
| 21.2  | 21.2 | 21.2 | 21.2 | 19.6 | 15.6 | 12.0 | ...  | ...   | B6        | A193      |
| 20.2  | 20.2 | 20.1 | 20.0 | 19.9 | 19.9 | 19.9 | 19.8 | 19.8  | 660A/B    | A453      |
| 22.0  | 22.0 | 22.0 | 22.0 | 22.0 | 10.9 | 10.8 | 10.7 | 10.6  | B8M Cl. 2 | A193      |
| 22.0  | 22.0 | 22.0 | 22.0 | 22.0 | 10.9 | 10.8 | 10.7 | 10.6  | B8M Cl. 2 | A320      |
| 25.0  | 25.0 | 25.0 | 25.0 | 25.0 | 25.0 | 25.0 | 25.0 | 25.0  | B8C Cl. 2 | A193      |
| 25.0  | 25.0 | 25.0 | 25.0 | 25.0 | 25.0 | 25.0 | 25.0 | 25.0  | B8C Cl. 2 | A320      |



**Table IX-4  
Design Stress Values for Bolting Materials (Cont'd)**

Specifications Are ASTM Unless Otherwise Indicated

| Material               | Spec. No. | Grade     | Size Range, Diam., in.        | Notes    | Min. Temp., °F [Note (1)] | Specified Min. Strength, ksi |       | Design Stress, ksi [Note (2)], at Metal Temperature, °F |      |      |      |      |
|------------------------|-----------|-----------|-------------------------------|----------|---------------------------|------------------------------|-------|---|------|------|------|------|
|                        |           |           |                               |          |                           | Tensile                      | Yield | Min. Temp. to 100                                       | 200  | 300  | 400  | 500  |
| <b>Stainless Steel</b> |           |           |                               |          |                           |                              |       |   |      |      |      |      |
| 304                    | A193      | B8 Cl. 2  | ≤ <sup>3</sup> / <sub>4</sub> | (6) (13) | -325                      | 125                          | 100   | 25.0  | 17.2 | 16.0 | 15.0 | 14.0 |
| 304                    | A320      | B8 Cl. 2  | ≤ <sup>3</sup> / <sub>4</sub> | (6) (13) | -325                      | 125                          | 100   | 25.0  | 17.2 | 16.0 | 15.0 | 14.0 |
| 321                    | A193      | B8T Cl. 2 | ≤ <sup>3</sup> / <sub>4</sub> | (6) (13) | -325                      | 125                          | 100   | 25.0  | 25.0 | 25.0 | 25.0 | 25.0 |
| 321                    | A320      | B8T Cl. 2 | ≤ <sup>3</sup> / <sub>4</sub> | (6) (13) | -325                      | 125                          | 100   | 25.0  | 25.0 | 25.0 | 25.0 | 25.0 |
| 12Cr                   | A437      | B4B       | ...                           | (8)      | -20                       | 145                          | 105   | 26.2  | 26.2 | 26.2 | 26.2 | 26.2 |
| 12Cr nuts              | A194      | 6         | ...                           | (8) (10) | -20                       | ...                          | ...   | ...   | ...  | ...  | ...  | ...  |
| 303 nuts               | A194      | 8FA       | ...                           | (10)     | -20                       | ...                          | ...   | ...   | ...  | ...  | ...  | ...  |
| 316 nuts               | A194      | 8MA       | ...                           | (10)     | -325                      | ...                          | ...   | ...   | ...  | ...  | ...  | ...  |
| 321 nuts               | A194      | 8TA       | ...                           | (10)     | -325                      | ...                          | ...   | ...   | ...  | ...  | ...  | ...  |
| 304 nuts               | A194      | 8         | ...                           | (10)     | -425                      | ...                          | ...   | ...   | ...  | ...  | ...  | ...  |
| 304 nuts               | A194      | 8A        | ...                           | (10)     | -425                      | ...                          | ...   | ...   | ...  | ...  | ...  | ...  |
| 347 nuts               | A194      | 8CA       | ...                           | (10)     | -425                      | ...                          | ...   | ...   | ...  | ...  | ...  | ...  |

**Table IX-4  
Design Stress Values for Bolting Materials (Cont'd)**  
Specifications Are ASTM Unless Otherwise Indicated

| Design Stress, ksi [Note (2)], at Metal Temperature, °F |      |      |      |      |      |      |      |       |           |           |
|---|------|------|------|------|------|------|------|-------|-----------|-----------|
| 600   | 650  | 700  | 750  | 800  | 850  | 900  | 950  | 1,000 | Grade     | Spec. No. |
| <b>Stainless Steel (Cont'd)</b>                         |      |      |      |      |      |      |      |       |           |           |
| 13.4  | 13.1 | 11.0 | 10.8 | 10.5 | 10.3 | 10.1 | 9.9  | 9.7   | B8 Cl. 2  | A193      |
| 13.4  | 13.1 | 11.0 | 10.8 | 10.5 | 10.3 | 10.1 | 9.9  | 9.7   | B8 Cl. 2  | A320      |
| 25.0  | 25.0 | 25.0 | 25.0 | 25.0 | 25.0 | 25.0 | 25.0 | 25.0  | B8T Cl. 2 | A193      |
| 25.0  | 25.0 | 25.0 | 25.0 | 25.0 | 25.0 | 25.0 | 25.0 | 25.0  | B8T Cl. 2 | A320      |
| 26.2  | 26.2 | 26.2 | ...  | ...  | ...  | ...  | ...  | ...   | B4B       | A437      |
| ...   | ...  | ...  | ...  | ...  | ...  | ...  | ...  | ...   | 6         | A194      |
| ...   | ...  | ...  | ...  | ...  | ...  | ...  | ...  | ...   | 8FA       | A194      |
| ...   | ...  | ...  | ...  | ...  | ...  | ...  | ...  | ...   | 8MA       | A194      |
| ...   | ...  | ...  | ...  | ...  | ...  | ...  | ...  | ...   | 8TA       | A194      |
| ...   | ...  | ...  | ...  | ...  | ...  | ...  | ...  | ...   | 8         | A194      |
| ...   | ...  | ...  | ...  | ...  | ...  | ...  | ...  | ...   | 8A        | A194      |
| ...   | ...  | ...  | ...  | ...  | ...  | ...  | ...  | ...   | 8CA       | A194      |

**Table IX-4  
Design Stress Values for Bolting Materials (Cont'd)**

Specifications Are ASTM Unless Otherwise Indicated

| Material                       | Spec. No. | UNS No. or Grade               | Temper<br>[Notes (4), (5)] | Size Range,<br>Diam., in. | Notes   | Min.<br>Temp., °F<br>[Note (1)] | Specified Min.<br>Strength, ksi |       |
|--------------------------------|-----------|--------------------------------|----------------------------|---------------------------|---------|---------------------------------|---------------------------------|-------|
|                                |           |                                |                            |                           |         |                                 | Tensile                         | Yield |
| <b>Copper and Copper Alloy</b> |           |                                |                            |                           |         |                                 |                                 |       |
| Naval brass                    | B21       | C46400, C48200, C48500         | O60                        | ...                       | ...     | -325                            | 50                              | 20    |
| Cu                             | B187      | C10200, C11000, C12000, C12200 | O60                        | ...                       | ...     | -325                            | 30                              | 10    |
| Cu-Si                          | B98       | C65100                         | O60                        | ...                       | (12)    | -325                            | 40                              | 12    |
| Cu-Si                          | B98       | C65500, C66100                 | O60                        | ...                       | (12)    | -325                            | 52                              | 15    |
| Cu-Si                          | B98       | C65500, C66100                 | H01                        | ...                       | ...     | -325                            | 55                              | 24    |
| Cu-Si                          | B98       | C65500, C66100                 | H02                        | ≤2                        | ...     | -325                            | 70                              | 38    |
| Cu-Si                          | B98       | C65100                         | H06                        | >1, ≤1½                   | ...     | -325                            | 75                              | 40    |
| Cu-Si                          | B98       | C65100                         | H06                        | >½, ≤1                    | ...     | -325                            | 75                              | 45    |
| Cu-Si                          | B98       | C65100                         | H06                        | ≤½                        | ...     | -325                            | 85                              | 55    |
| Al-Si-bronze                   | B150      | C64200                         | HR50                       | >1, ≤2                    | ...     | -325                            | 80                              | 42    |
| Al-Si-bronze                   | B150      | C64200                         | HR50                       | >½, ≤1                    | ...     | -325                            | 85                              | 42    |
| Al-Si-bronze                   | B150      | C64200                         | HR50                       | ≤½                        | ...     | -325                            | 90                              | 42    |
| Al-bronze                      | B150      | C61400                         | HR50                       | >1, ≤2                    | ...     | -325                            | 70                              | 32    |
| Al-bronze                      | B150      | C61400                         | HR50                       | >½, ≤1                    | ...     | -325                            | 75                              | 35    |
| Al-bronze                      | B150      | C61400                         | HR50                       | ≤½                        | ...     | -325                            | 80                              | 40    |
| Al-bronze                      | B150      | C63000                         | HR50                       | >2, ≤3                    | ...     | -325                            | 85                              | 42.5  |
| Al-bronze                      | B150      | C63000                         | M20                        | >3, ≤4                    | ...     | -325                            | 85                              | 42.5  |
| Al-bronze                      | B150      | C63000                         | HR50                       | >1, ≤2                    | ...     | -325                            | 90                              | 45    |
| Al-bronze                      | B150      | C63000                         | HR50                       | >½, ≤1                    | ...     | -325                            | 100                             | 50    |
| <b>Nickel and Nickel Alloy</b> |           |                                |                            |                           |         |                                 |                                 |       |
| Ni-Cu                          | B164      | N04400                         | C.D./str. rel.             | ...                       | ...     | -325                            | 84                              | 50    |
| Ni-Cu                          | B164      | N04400                         | Cold drawn                 | ...                       | ...     | -325                            | 85                              | 55    |
| Ni-Cu                          | B164      | N04400, N04405                 | Annealed                   | ...                       | ...     | -325                            | 70                              | 25    |
| Ni-Cu                          | B164      | N04400                         | Hot fin.                   | 2⅛ ≤hex. ≤4               | ...     | -325                            | 75                              | 30    |
| Ni-Cu                          | B164      | N04400                         | Hot fin.                   | All except hex. >2⅛       | ...     | -325                            | 80                              | 40    |
| <b>Aluminum Alloy</b>          |           |                                |                            |                           |         |                                 |                                 |       |
| ...                            | B211      | 6061                           | T6, T651 wld.              | ≥⅛, ≤8                    | (3)(11) | -452                            | 24                              | ...   |
| ...                            | B211      | 6061                           | T6, T651                   | ≥⅛, ≤8                    | (3)(11) | -452                            | 42                              | 35    |
| ...                            | B211      | 2024                           | T4                         | >6½, ≤8                   | (3)(11) | -452                            | 58                              | 38    |
| ...                            | B211      | 2024                           | T4                         | >4½, ≤6½                  | (3)(11) | -452                            | 62                              | 40    |
| ...                            | B211      | 2024                           | T4                         | >½, ≤4½                   | (3)(11) | -452                            | 62                              | 42    |
| ...                            | B211      | 2024                           | T4                         | ≥⅛, <½                    | (3)(11) | -452                            | 62                              | 45    |
| ...                            | B211      | 2014                           | T6, T651                   | ≥⅛, ≤8                    | (3)(11) | -452                            | 65                              | 55    |

**Table IX-4  
Design Stress Values for Bolting Materials (Cont'd)**  
Specifications Are ASTM Unless Otherwise Indicated

| Min. Temp. to 100              | Design Stress, ksi [Note (1)], at Metal Temperature, °F [Note (7)] |      |      |      |      |      |      |      |      |      |     |     |       | UNS No. or Grade | Spec. No.    |      |
|--------------------------------|--|------|------|------|------|------|------|------|------|------|-----|-----|-------|------------------|--------------|------|
|                                | 200  | 300  | 400  | 500  | 600  | 650  | 700  | 750  | 800  | 850  | 900 | 950 | 1,000 |                  |              |      |
| <b>Copper and Copper Alloy</b> |  |      |      |      |      |      |      |      |      |      |     |     |       |                  |              |      |
| 5.0                            | 4.8  | 4.2  | ...  | ...  | ...  | ...  | ...  | ...  | ...  | ...  | ... | ... | ...   | ...              | C46400, etc. | B21  |
| 6.7                            | 5.5  | 5.1  | ...  | ...  | ...  | ...  | ...  | ...  | ...  | ...  | ... | ... | ...   | ...              | C10200, etc. | B187 |
| 8.0                            | 8.0  | 7.9  | ...  | ...  | ...  | ...  | ...  | ...  | ...  | ...  | ... | ... | ...   | ...              | C65100       | B98  |
| 10.0                           | 10.0   | 10.0 | ...  | ...  | ...  | ...  | ...  | ...  | ...  | ...  | ... | ... | ...   | ...              | C65500, etc. | B98  |
| 10.0                           | 10.0   | 10.0 | ...  | ...  | ...  | ...  | ...  | ...  | ...  | ...  | ... | ... | ...   | ...              | C65500, etc. | B98  |
| 10.0                           | 10.0   | 10.0 | ...  | ...  | ...  | ...  | ...  | ...  | ...  | ...  | ... | ... | ...   | ...              | C65500, etc. | B98  |
| 10.0                           | 10.0   | 10.0 | ...  | ...  | ...  | ...  | ...  | ...  | ...  | ...  | ... | ... | ...   | ...              | C65100       | B98  |
| 11.3                           | 11.3   | 11.3 | ...  | ...  | ...  | ...  | ...  | ...  | ...  | ...  | ... | ... | ...   | ...              | C65100       | B98  |
| 13.7                           | 13.7   | 13.7 | ...  | ...  | ...  | ...  | ...  | ...  | ...  | ...  | ... | ... | ...   | ...              | C65100       | B98  |
| 16.7                           | 14.0   | 13.5 | 11.0 | 5.2  | 1.7  | ...  | ...  | ...  | ...  | ...  | ... | ... | ...   | ...              | C64200       | B150 |
| 16.7                           | 14.0   | 13.5 | 11.0 | 5.2  | 1.7  | ...  | ...  | ...  | ...  | ...  | ... | ... | ...   | ...              | C64200       | B150 |
| 16.7                           | 14.0   | 13.5 | 11.0 | 5.2  | 1.7  | ...  | ...  | ...  | ...  | ...  | ... | ... | ...   | ...              | C64200       | B150 |
| 17.5                           | 17.5   | 17.5 | 17.5 | 16.8 | ...  | ...  | ...  | ...  | ...  | ...  | ... | ... | ...   | ...              | C61400       | B150 |
| 17.5                           | 17.5   | 17.5 | 17.5 | 16.8 | ...  | ...  | ...  | ...  | ...  | ...  | ... | ... | ...   | ...              | C61400       | B150 |
| 17.5                           | 17.5   | 17.5 | 17.5 | 16.8 | ...  | ...  | ...  | ...  | ...  | ...  | ... | ... | ...   | ...              | C61400       | B150 |
| 20.0                           | 20.0   | 20.0 | 20.0 | 19.4 | 12.0 | 8.5  | 6.0  | ...  | ...  | ...  | ... | ... | ...   | ...              | C63000       | B150 |
| 20.0                           | 20.0   | 20.0 | 20.0 | 19.4 | 12.0 | 8.5  | 6.0  | ...  | ...  | ...  | ... | ... | ...   | ...              | C63000       | B150 |
| 20.0                           | 20.0   | 20.0 | 20.0 | 19.4 | 12.0 | 8.5  | 6.0  | ...  | ...  | ...  | ... | ... | ...   | ...              | C63000       | B150 |
| 20.0                           | 20.0   | 20.0 | 20.0 | 19.4 | 12.0 | 8.5  | 6.0  | ...  | ...  | ...  | ... | ... | ...   | ...              | C63000       | B150 |
| <b>Nickel and Nickel Alloy</b> |  |      |      |      |      |      |      |      |      |      |     |     |       |                  |              |      |
| 12.5                           | 12.5   | 12.5 | 12.5 | 12.5 | ...  | ...  | ...  | ...  | ...  | ...  | ... | ... | ...   | ...              | N04400       | B164 |
| 13.7                           | 13.7   | 13.7 | 13.7 | 13.7 | ...  | ...  | ...  | ...  | ...  | ...  | ... | ... | ...   | ...              | N04400       | B164 |
| 16.6                           | 14.6   | 13.6 | 13.2 | 13.1 | 13.1 | 13.1 | 13.1 | 13.0 | 12.7 | 11.0 | 8.0 | ... | ...   | ...              | N04400, etc. | B164 |
| 18.7                           | 18.7   | 18.7 | 18.7 | 17.8 | 17.4 | 17.2 | 17.0 | 16.8 | 14.5 | 8.5  | 4.0 | ... | ...   | ...              | N04400       | B164 |
| 20.0                           | 20.0   | 20.0 | 20.0 | 20.0 | 20.0 | 20.0 | 19.2 | 18.5 | 14.5 | 8.5  | 4.0 | ... | ...   | ...              | N04400       | B164 |
| <b>Aluminium Alloy</b>         |  |      |      |      |      |      |      |      |      |      |     |     |       |                  |              |      |
| 4.8                            | 4.8  | 4.8  | 3.5  | ...  | ...  | ...  | ...  | ...  | ...  | ...  | ... | ... | ...   | ...              | 6061         | B211 |
| 8.4                            | 8.4  | 8.4  | 4.4  | ...  | ...  | ...  | ...  | ...  | ...  | ...  | ... | ... | ...   | ...              | 6061         | B211 |
| 9.5                            | 9.5  | 9.5  | 4.2  | ...  | ...  | ...  | ...  | ...  | ...  | ...  | ... | ... | ...   | ...              | 2024         | B211 |
| 10.0                           | 10.0   | 10.0 | 4.5  | ...  | ...  | ...  | ...  | ...  | ...  | ...  | ... | ... | ...   | ...              | 2024         | B211 |
| 10.5                           | 10.5   | 10.4 | 4.5  | ...  | ...  | ...  | ...  | ...  | ...  | ...  | ... | ... | ...   | ...              | 2024         | B211 |
| 11.3                           | 11.3   | 10.4 | 4.5  | ...  | ...  | ...  | ...  | ...  | ...  | ...  | ... | ... | ...   | ...              | 2024         | B211 |
| 13.0                           | 13.0   | 11.4 | 3.9  | ...  | ...  | ...  | ...  | ...  | ...  | ...  | ... | ... | ...   | ...              | 2014         | B211 |

**Table IX-4**  
**Design Stress Values for Bolting Materials (Cont'd)**

GENERAL NOTE: Notes marked with an asterisk (\*) restate requirements found in the text of the Code.

NOTES:

- (1) \*The minimum temperature shown is that design minimum temperature for which the material is normally suitable without impact testing other than that required by the material specification. However, the use of a material at a design minimum temperature below  $-20^{\circ}\text{F}$  ( $-29^{\circ}\text{C}$ ) is established by rules elsewhere in this Code, including [para. GR-2.1.2\(b\)](#) and other impact test requirements.
- (2) \*The stress values are basic allowable stresses in tension in accordance with [para. IP-2.2.6\(a\)](#).
- (3) For stress-relieved tempers (T351, T3510, T3511, T451, T4510, T4511, T651, T6510, and T6511), stress values for material in the listed temper shall be used.
- (4) For copper and copper alloy materials, the following symbols are used in the Temper column:
  - (a) O60 = soft anneal
  - (b) H01 = quarter-hard
  - (c) H02 = half-hard
  - (d) H06 = extra hard
  - (e) HR50 = drawn, stress relieved
  - (f) M20 = hot rolled
- (5) For nickel and nickel alloy materials, the following abbreviations are used in the Temper column: C.D., cold drawn; M20, hot rolled; and str. rel., stress relieved.
- (6) These stress values are established from a consideration of strength only and will be satisfactory for average service. For bolted joints where freedom from leakage over a long period of time without retightening is required, lower stress values may be necessary as determined from the flexibility of the flange and bolts, and corresponding relaxation properties.
- (7) For temperatures above  $1,000^{\circ}\text{F}$  ( $538^{\circ}\text{C}$ ), these stress values apply only when the carbon content is 0.04% or higher.
- (8) This steel is intended for use at high temperatures; it may have low ductility and/or low impact properties at room temperature. See also [para. GR-2.1.4\(b\)\(3\)\(c\)](#).
- (9) This material, when used below  $-20^{\circ}\text{F}$  ( $-29^{\circ}\text{C}$ ), shall be impact tested if the carbon content is above 0.10%.
- (10) This is a product specification. No design stresses are necessary. Limitations on metal temperature for materials covered by this specification are:

| Metal Grade(s)                      | Temperature, °F (°C)        |
|-------------------------------------|-----------------------------|
| 1                                   | -20 to 900 (-29 to 482)     |
| 2, 2H, and 2HM                      | -55 to 1,100 (-48 to 593)   |
| 3                                   | -20 to 1,100 (-29 to 593)   |
| 4 [see (a) below]                   | -150 to 1,100 (-101 to 593) |
| 6                                   | -20 to 800 (-29 to 427)     |
| 7 and 7M [see (a) below]            | -150 to 1,100 (-101 to 593) |
| 8FA [see <a href="#">Note (9)</a> ] | -20 to 800 (-29 to 427)     |
| 8MA and 8TA                         | -325 to 1,500 (-198 to 816) |
| 8, 8A, and 8CA                      | -425 to 1,500 (-254 to 816) |

(a) When used below  $-50^{\circ}\text{F}$  ( $-46^{\circ}\text{C}$ ), this material shall be impact tested as required by ASTM A320 for Grade L7.

(b) This is a product specification. No design stresses are necessary.

- (11) \*The stress values given for this material are not applicable when either welding or thermal cutting is employed [see [para. GR-2.1.4\(b\)\(3\)](#)].
- (12) Copper-silicon alloys are not always suitable when exposed to certain media and high temperature, particularly above  $212^{\circ}\text{F}$  ( $100^{\circ}\text{C}$ ). The user should satisfy him/herself that the alloy selected is satisfactory for the service for which it is to be used.
- (13) For all design temperatures, the maximum hardness shall be Rockwell C35 immediately under the thread roots. The hardness shall be taken on a flat area at least  $\frac{1}{8}$  in. (3 mm) across, prepared by removing threads. No more material than necessary shall be removed to prepare the area. Hardness determination shall be made at the same frequency as tensile tests.

**Table IX-5A**  
**Carbon Steel Pipeline Materials Performance Factor,  $H_f$**

| Specified Min. Strength, ksi |       | System Design Pressure, psig |       |       |       |       |       |       |
|------------------------------|-------|------------------------------|-------|-------|-------|-------|-------|-------|
| Tensile                      | Yield | ≤1,000                       | 2,000 | 2,200 | 2,400 | 2,600 | 2,800 | 3,000 |
| 66 and under                 | ≤52   | 1.0                          | 1.0   | 0.954 | 0.910 | 0.880 | 0.840 | 0.780 |
| Over 66 through 75           | ≤60   | 0.874                        | 0.874 | 0.834 | 0.796 | 0.770 | 0.734 | 0.682 |
| Over 75 through 82           | ≤70   | 0.776                        | 0.776 | 0.742 | 0.706 | 0.684 | 0.652 | 0.606 |
| Over 82 through 90           | ≤80   | 0.694                        | 0.694 | 0.662 | 0.632 | 0.610 | 0.584 | 0.542 |

## GENERAL NOTES:

- (a) Tables IX-5A, IX-5B, and IX-5C are for use in designing carbon steel, low, and intermediate alloy piping and pipeline systems that will have a design temperature within the hydrogen embrittlement range of the selected material [recommended lowest service temperature up to 300°F (150°C)]. If the system design temperature is out of this range, use the design allowable stresses from Table IX-1A for piping or the specified minimum yield strength for pipelines from Table IX-1B.
- (b) Table IX-5A was developed for pipeline systems and as such the design factors are based on the specified minimum yield strength of the material ranges shown.
- (c) Design factors may be calculated by interpolation between pressures shown in the tables.
- (d) For materials not covered by Tables IX-5A, IX-5B, and IX-5C, use the allowable stresses in Table IX-1A.

**Table IX-5B**  
**Carbon Steel Piping Materials Performance Factor,  $M_f$**

| Specified Min. Strength, ksi |       | System Design Pressure, psig |       |       |       |       |       |
|------------------------------|-------|------------------------------|-------|-------|-------|-------|-------|
| Tensile                      | Yield | ≤1,000                       | 2,000 | 3,000 | 4,000 | 5,000 | 6,000 |
| 70 and under                 | ≤52   | 1.0                          | 0.948 | 0.912 | 0.884 | 0.860 | 0.839 |
| Over 70 through 75           | ≤56   | 0.930                        | 0.881 | 0.848 | 0.824 | 0.800 | 0.778 |
| Over 75 through 80           | ≤65   | 0.839                        | 0.796 | 0.766 | 0.745 | 0.724 | 0.706 |
| Over 80 through 90           | ≤80   | 0.715                        | 0.678 | 0.645 | 0.633 | 0.618 | 0.600 |

## GENERAL NOTES:

- (a) Tables IX-5A, IX-5B, and IX-5C are for use in designing carbon steel, low, and intermediate alloy piping and pipeline systems that will have a design temperature within the hydrogen embrittlement range of the selected material [recommended lowest service temperature up to 300°F (150°C)]. If the system design temperature is out of this range, use the design allowable stresses from Table IX-1A for piping or the specified minimum yield strength for pipelines from Table IX-1B.
- (b) Tables IX-5B and IX-5C were developed for piping systems and as such the design factors are based on the specified minimum tensile strength of the material ranges shown.
- (c) Design factors may be calculated by interpolation between pressures shown in the tables.
- (d) For materials not covered by Tables IX-5A, IX-5B, and IX-5C, use the allowable stresses in Table IX-1A.

**Table IX-5C**  
**Low and Intermediate Alloy Steels Performance Factor,  $M_f$**

| Specified Min. Strength, ksi |       | System Design Pressure, psig |       |       |       |       |       |       |
|------------------------------|-------|------------------------------|-------|-------|-------|-------|-------|-------|
| Tensile                      | Yield | 0.00                         | 1,000 | 2,000 | 3,000 | 4,000 | 5,000 | 6,000 |
| 60 and under                 | ≤35   | 1.0                          | 0.918 | 0.881 | 0.875 | 0.836 | 0.815 | 0.800 |
| Over 60 through 75           | ≤45   | 0.791                        | 0.724 | 0.696 | 0.675 | 0.660 | 0.642 | 0.630 |
| Over 75 through 85           | ≤60   | 0.655                        | 0.601 | 0.577 | 0.561 | 0.547 | 0.533 | 0.524 |
| Over 85 through 90           | ≤65   | 0.580                        | 0.532 | 0.511 | 0.497 | 0.485 | 0.472 | 0.464 |

## GENERAL NOTES:

- (a) Tables IX-5A, IX-5B, and IX-5C are for use in designing carbon steel, low, and intermediate alloy piping and pipeline systems that will have a design temperature within the hydrogen embrittlement range of the selected material [recommended lowest service temperature up to 300°F (150°C)]. If the system design temperature is out of this range, use the design allowable stresses from Table IX-1A for piping or the specified minimum yield strength for pipelines from Table IX-1B.
- (b) Tables IX-5B and IX-5C were developed for piping systems and as such the design factors are based on the specified minimum tensile strength of the material ranges shown.
- (c) Design factors may be calculated by interpolation between pressures shown in the tables.
- (d) For materials not covered by Tables IX-5A, IX-5B, and IX-5C, use the allowable stresses in Table IX-1A.

# NONMANDATORY APPENDIX A

## PRECAUTIONARY CONSIDERATIONS

### A-1 GENERAL

#### A-1.1 Introduction

This Appendix provides guidance in the form of precautionary considerations relating to hydrogen service and piping applications. These are not Code requirements but should be taken into account as applicable in the engineering design. Further information on these subjects can be found in the literature.

With the emergence of the new hydrogen economy and infrastructure, it is believed that piping and pipeline systems will need to be operated at pressures with possible cyclic pressure loading in excess of our current operating regimes. It is expected that hydrogen piping systems will have to be operated up to 100 MPa (15,000 psig), transport pipelines will operate up to 20 MPa (3,000 psig), and both piping and pipeline systems will be operating at or below 150°C (300°F). In doing so, the metallic pipe materials in use today could be placed in an operating environment for which we currently have little or no data on their mechanical properties and behavior in a dry hydrogen environment.

#### A-1.2 Ventilated Location

In order to ensure adequate ventilation, the normal practice is to provide ventilation rates high enough to dilute hydrogen leaks of 25% of the LFL, i.e., about 1% by volume air. In some jurisdictions, this is a requirement.

### (23) A-2 MATERIALS

Table A-2-1 provides a general guideline on materials compatibility in hydrogen service. Refer to Chapter GR-2.

#### A-2.1 Materials for Hydrogen Gas Service

Although details on effects of composition and microstructure on hydrogen embrittlement in structural metals have not been fully elucidated, there are bodies of engineering data for some materials. Existing data demonstrate some clear trends that can assist in materials selection for hydrogen service.

The most general and technologically important trend for structural metals is that susceptibility to hydrogen embrittlement increases as the material strength increases. This basic trend has been documented for a

number of structural metals. Data showing the effect of yield strength on the threshold stress intensity factor,  $K_{TH}$ , for hydrogen-assisted fracture show that  $K_{TH}$  decreases as yield strength increases. Since the effect of material strength on fracture in hydrogen gas can be so severe, all structural designs for hydrogen gas service should not only specify minimum yield strength but also maximum yield strength for managing hydrogen embrittlement.

#### A-2.2 Carbon Steels

(23)

Carbon steels have been used for hydrogen piping and gas pipelines in welded construction for many decades. Industrial gas companies operate over thousands of miles of pipeline in the United States and Europe. Examples of steels that have been proven for hydrogen gas service are conventional ASTM A106 Grade B, ASTM A53 Grade B, and API 5L Grades X42 and X52 (PSL2 grades preferred), as well as microalloyed API 5L Grade X52.<sup>1</sup> Long-distance hydrogen gas pipelines have been operated at gas pressures up to 14 MPa (2,000 psi).

Guidelines exist on tailoring the metallurgy of carbon steels for hydrogen gas service. The European Industrial Gas Association (EIGA) and the Compressed Gas Association (CGA) created a document, IGC Doc 121/04/E (also published as CGA G-5.6), that provides guidance on good practices for hydrogen gas pipelines. With respect to materials selection, this document recommends API 5L PSL2 Grades X42 and X52 for hydrogen gas service.

Additionally, microalloy versions of X42 and X52 grades appear to enhance resistance to hydrogen embrittlement.

Additional recommendations are provided in ASME STP/PT-003 and ASME STP/PT-006.

In general, hydrogen-assisted fracture tends to be reduced at elevated temperature. For carbon steels, however, hydrogen attack becomes an important consideration above 200°C (392°F). Hydrogen attack involves a chemical reaction between hydrogen and carbon, which leads to formation of fissures containing high-pressure methane gas and decarburization in the steel. The American Petroleum Institute (API) provides data on hydrogen attack in recommended practice RP 941, which contains the Nelson curves for carbon-manganese and chromium-

<sup>1</sup> There are currently no standard API 5L microalloy grades. The purchaser would have to specify appropriate supplemental requirements to achieve the benefits of microalloy steel.



**Table A-2-1**  
**Materials Compatible With Hydrogen Service**

(23)

| Material Group  | Form of Hydrogen |                | Notes  |
|---|------------------|----------------|--|
|   | Gas              | Liquid         |  |
| Aluminum-based alloys   | Acceptable       | Acceptable     | ...  |
| Austenitic stainless steels with greater than 8 wt% nickel in solution annealed condition | Acceptable       | Acceptable     | Temperature- or stress-induced martensite transformation due to unstable austenite   |
| Copper-based alloys   | Acceptable       | Acceptable     | ...  |
| Low and intermediate strength carbon and low alloy steels                                 | Acceptable       | Not acceptable | Cryogenic temperature embrittlement  |
| Cast irons  | Not acceptable   | Not acceptable | Not permitted for hydrogen service   |
| Nickel-based alloys   | See Note         | Acceptable     | Acceptability in gaseous hydrogen depending on strength and alloy composition. Some alloys may exhibit severe hydrogen embrittlement |
| Titanium-based alloys   | Not acceptable   | Acceptable     | Titanium hydride formation   |

molybdenum steels, identifying the hydrogen pressure and temperature ranges at which hydrogen attack is a concern.

### A-2.3 Low-Alloy Carbon Steels

Low-alloy carbon steel pipe materials are normally used to resist the effects of high temperature and corrosion in piping systems. Following on the carbon steel discussion, the effects of hydrogen embrittlement are more pronounced as the tensile and yield strength of the material increases. In general, alloying elements such as carbon, manganese, sulfur, phosphorus, and chromium impart greater susceptibility to hydrogen embrittlement in low-alloy steels. This class of materials is more difficult to weld, and welds may have a high hardness, which can lead to subcritical crack growth. The material test data for this group of pipe materials are lacking, and designers are cautioned in selection of these materials for dry hydrogen gas service in the hydrogen embrittlement temperature range.

### (23) A-2.4 Austenitic Stainless Steels

Austenitic steels are the most resistant to hydrogen embrittlement among the stainless steels and have been successfully used in high-pressure hydrogen gas piping and pressure vessels. Austenitic stainless steels generally provide the best performance of any structural metal in hydrogen gas service.

Hydrogen embrittlement in single-phase austenitic stainless steels has been primarily correlated with two metallurgical variables: alloy composition and the presence of second phases, such as ferrite and martensite. Ferrite can be present in austenitic stainless steels as a result of material processing, while martensite can be induced by mechanical straining. Both ferrite and strain-induced martensite render austenitic stainless steels more vulnerable to hydrogen embrittlement. The

ferrite and martensite can be intrinsically more susceptible to hydrogen-assisted fracture than the austenite matrix. Additionally, ferrite and martensite can enhance hydrogen uptake in the steels, since hydrogen diffuses more rapidly in these body-centered cubic (BCC) phases compared with the face-centered cubic (FCC) austenite matrix.

Alloy composition is perhaps the most important metallurgical variable governing hydrogen embrittlement in single-phase austenitic stainless steels and has been correlated with the wide range in embrittlement resistance among these steels. As an austenite stabilizer, higher nickel content, in particular, correlates well with resistance to hydrogen embrittlement. Data seem to indicate that more-stable austenitic stainless steels are preferable for hydrogen gas service. For example, 316 with Ni content >12 wt% is a good choice among the common single-phase austenitic stainless steels.

### A-2.5 Highly Alloyed Steels

(23)

High alloy steels are defined as steels with the iron content less than 90 wt%. The properties of these steels in hydrogen environments are complicated. It is strongly recommended to consult with materials professionals for compatibility issues.

### A-2.6 Aluminum Alloys

(23)

The published service experience and laboratory data on aluminum alloys in hydrogen gas are limited. This information indicates that aluminum alloys are highly resistant to hydrogen embrittlement in dry hydrogen gas. Any gas containing water vapor, however, can create conditions for stress corrosion cracking (SCC) of high strength aluminum alloys.

In summary, aluminum alloys should be used judiciously for hydrogen gas service if water vapor is present; however, all available data indicate that the

susceptibility of aluminum to hydrogen embrittlement is very low in dry hydrogen gas.

### A-2.7 Other Nonferrous Alloys

Although not commonly used for structural applications in hydrogen gas, copper has low hydrogen permeability, making this material a candidate for sealing applications. Copper can be embrittled in hydrogen gas due to a reaction between dissolved hydrogen and oxygen (either in solution or from oxides) to form water, resulting in pores that promote failure. Consequently, oxygen-free grades of copper should be used for hydrogen gas service.

### A-2.8 Environmental and Mechanical Variables

The previous sections provided general guidance on materials for hydrogen gas service and emphasized the metallurgical variables that influence hydrogen embrittlement. This section describes additional factors that impact hydrogen embrittlement, primarily environmental and mechanical-loading conditions.

**A-2.8.1 Pressure and Temperature.** An important general trend is that structural metals become more susceptible to hydrogen embrittlement as hydrogen gas pressure increases. An example of this trend is the measured threshold stress intensity factor,  $K_{TH}$ , as a function of gas pressure for low-alloy steels.  $K_{TH}$  decreases as gas pressure increases. Increasing hydrogen gas pressure enhances the concentration of dissolved hydrogen in materials, which promotes hydrogen embrittlement.

In contrast to gas pressure, the effect of temperature on hydrogen embrittlement is not as general. Carbon and low-alloy steels exhibit less severe hydrogen embrittlement as temperature increases. As mentioned previously, carbon and low-alloy steels subjected to elevated temperature for prolonged periods [above about 200°C (392°F) for carbon steels and somewhat higher for low-alloy steels] are susceptible to hydrogen attack. At low temperature, use of these steels in pressure-bearing applications may be limited by their intrinsic toughness, as many steels exhibit a ductile to brittle transition.

### A-2.9 Hydrogen Transport

Hydrogen gas molecules adsorb onto metal surfaces, like many atmospheric gases, and dissociate to its atomic form. Unlike other atomic adsorbates at near-ambient temperatures, however, hydrogen will diffuse into the metal lattice with two important consequences

- (a) hydrogen will diffuse from high to low concentrations, effectively permeating through a metal structure that contains hydrogen gas
- (b) dissolved hydrogen can degrade the properties of the metal

This latter characteristic is the topic of subsequent sections of this Appendix.

### A-2.10 Hydrogen Embrittlement [See Para. GR-2.1(b)]

(23)

General guidance is provided on materials selection for piping and pipelines where gaseous hydrogen embrittlement is a concern. All structural metals are susceptible to hydrogen embrittlement, although the severity of embrittlement depends on particular material properties and the service environment. Variables that can govern hydrogen embrittlement in structural metals include material strength, microstructure, and composition, as well as gas pressure, temperature, and mechanical loading. Because no structural metal can be labeled as “immune” to hydrogen embrittlement, designing structures for hydrogen service does not involve simply selecting a material from a list of “hydrogen-compatible” alloys.

Hydrogen embrittlement of materials may manifest itself as a loss in strength or ductility or both, a loss in notched strength and ductility, accelerated fatigue crack growth rates, and a reduction in fracture toughness. The degree of embrittlement strongly depends on materials, hydrogen pressure, hydrogen purity, and environment temperature. The interactions between materials and hydrogen environment are very complicated. It is strongly recommended to consult with materials professionals for compatibility issues.

**A-2.10.1 Hydrogen Mixtures or Blends.** In the case of mixtures of hydrogen with other gases, the material degradation effect of hydrogen should be considered. Even small additions of hydrogen to a nondamaging gas mixture may result in a reduction in fatigue life and fracture resistance of the materials in a piping or pipeline system. The technical literature indicates that a mixture or blend with hydrogen can adversely affect the properties of materials when the hydrogen partial pressure is as low as 100 kPa (15 psi). (23)

### A-2.11 Hydrogen Damage (See Para. GR-2.1.4)

Hydrogen shall be stored, handled, and used so life and health are not jeopardized and the risk of property damage is minimized.

**A-2.11.1 Storage Vessel Failure.** The release of gaseous hydrogen,  $\text{GH}_2$ , or liquid hydrogen,  $\text{LH}_2$ , may result in ignition and combustion, causing fires and explosions. Damage may extend over considerably wider areas than the storage locations because of hydrogen cloud movement. Vessel failure may be started by material failure, excessive pressure caused by heat leak, or failure of the pressure-relief system.

**A-2.11.2 Thermal Energy Radiated From Flame to Surroundings.** Exposure to hydrogen fires can result in significant damage from thermal radiation. Thermal radiation is affected by the amount of water vapor in the atmosphere.

### A-2.12 Material Considerations for Nonmetals [See Para. GR-2.1(b)]

Due to the possibility of producing electrostatic charges, consideration should be given to grounding the metallic components of piping systems conveying nonconductive fluids.

### (23) A-2.13 Guidance on High-Pressure Piping Designed to ASME B31.3, Chapter IX

The rules in ASME B31.3, Chapter IX provide an alternative to those in Chapters I through VI. They include special considerations for thick-walled piping components such as the theory of failure and the approaches to fatigue and thermal stresses, generally resulting in lower design factors with respect to burst strength than the base code. ASME B31.3, Chapter IX rules may allow thinner piping components than the base code, resulting in lower piping weight, balanced against increased requirements for material testing, fatigue analysis, fabrication, and examination. Although high-pressure fluid service is often considered to be service exceeding that allowed by the ASME B16.5, Class 2500 pressure-temperature rating for a particular material group, there are no pressure limitations for the application of these rules. The basis of the decision by an owner to specify high-pressure fluid service is a function of the economic, technical, and other issues pertaining to the piping. (See ASME B31.3, para. FK300.)

Materials listed in Table A-2-1 should be used. Materials not listed in Table A-2-1 may be used, provided the applicable rules of ASME BPVC, Section VIII, Division 3, Article KD-10 are satisfied. Material performance factor,  $M_f$ , specified in Mandatory Appendix IX, Tables IX-5B and IX-5C, should be applied to the allowable stress,  $S$ , in all minimum wall thickness or pressure calculations. If  $M_f$  is not provided for a given material and pressure combination in Mandatory Appendix IX, Tables IX-5B and IX-5C, then the design should satisfy the applicable rules of ASME BPVC, Section VIII, Division 3, Article KD-10.

### A-3 WELDING, BRAZING, HEAT TREATING, FORMING, AND TESTING (SEE CHAPTER GR-3)

Prior to welding in or around a structure or area containing gas facilities, a thorough check shall be made to determine the possible presence of a combustible gas mixture. Welding shall begin only when safe conditions are indicated.

#### A-3.1 Mechanized Welding Considerations

- (23) **A-3.1.1 Welding With the Addition of Filler Metal [See Para. GR-3.2.5(b)(2)].** The ends to be welded shall be prepared by machining or facing to provide a square end that meets the requirements of ANSI standards for

tubing. The weld joints shall be properly cleaned within 13 mm ( $\frac{1}{2}$  in.) of the joint area on the inside and outside surfaces prior to welding. All process surface joints shall have complete weld penetration, whether welded from one side or both sides. The joint must allow for proper purge gas coverage on the process side.

**A-3.1.2 Sulfur Content [See Para. GR-3.2.5(b)(4)].** The user should be aware of sulfur contents when welding unmatched heats together. When one heat is low in sulfur (0.001% to 0.008%) and the other is in the medium to high range (0.009% to 0.030%), the arc may deflect towards the low sulfur heat, causing the weld bead to miss the weld joint, with a tendency towards O.D. concavity. The Marangoni Effect dictates that minor changes in sulfur content can change weld pool flow characteristics, with a dramatic effect on penetration.

**A-3.1.3 Purge Gas [See Para. GR-3.2.5(b)(6)].** Purge gas for LH<sub>2</sub> and cold GH<sub>2</sub> lines shall be gaseous helium, GHe. Neither gaseous nitrogen, GN<sub>2</sub>, nor liquid nitrogen, LN<sub>2</sub>, shall be introduced into any LH<sub>2</sub> line that interfaces with a liquid storage tank cold port. Precautions shall be taken to prevent cross-mixing of media through common purge lines by use of check valves to prevent backflow from a system into a purge distribution manifold.

#### A-3.2 Welding Electrodes and Filler Metal [See Para. GR-3.3.1]

Unless otherwise specified by engineering design, welding electrodes and filler metals used shall produce weld metal that complies with the following:

(a) *Weld Metal Strength.* The nominal tensile strength of the weld metal shall equal or exceed the minimum specified tensile strength of the base metals being joined.

(b) *Differential Strength.* If base metals of different tensile strengths are to be joined, the nominal tensile strength of the weld metal shall equal or exceed the minimum specified tensile strength of the weaker of the two.

(c) *Weld Metal Chemical Analysis.* The nominal chemical analysis of the weld metal shall be similar to the nominal chemical analysis of the major alloying elements of the base metal (e.g., 2 $\frac{1}{4}$ % Cr, 1% Mo steels should be joined using 2 $\frac{1}{4}$ % Cr, 1% Mo filler metals).

(d) *Base Metal Chemical Analysis.* If base metals of different chemical analysis are being joined, the nominal chemical analysis of the weld metal shall be similar to either base metal or an intermediate composition, except as specified below for austenitic steels joined to ferritic steels.

(e) *Steel Joining.* When austenitic steels are joined to ferritic steels, the weld metal shall have an austenitic structure.

(f) *Nonferrous Metal Welds.* For nonferrous metals, the weld metal shall be that recommended by the manufacturer of the nonferrous metal or by industry associations for that metal.

(g) *Other Materials.* For materials or combinations of materials not yet incorporated in the Code, engineering design shall specify the weld metal that is required.

(h) *Weldability Testing.* Design engineering shall designate the tests to evaluate the susceptibility of the weld metal and heat affected zone to hydrogen cracking in accordance with ANSI/AWS B4.0.

(i) *Diffusible Hydrogen Control.* To control hydrogen-induced cracking, the hydrogen level must be held to a certain maximum level. The applicable SFA-5.X filler metal specification electrodes, electrode-flux combinations, or electrodes and rods for gas-shielded arc welding capable of depositing weld metal with a maximum diffusible hydrogen content of 4 mL/100g (H4) are permitted. When purchasing electrodes and filler metal, the supplemental diffusible hydrogen designator shall be specified. An assessment of the diffusible hydrogen content is to be made according to one of the methods given in ANSI/AWS A4.3.

(j) *Packaging.* Electrodes shall be packaged in hermetically sealed containers.

### A-3.3 Construction of Brazements (See Para. GR-3.8)

No unique problems have been encountered with silver braze materials. The choice of braze composition is determined by ease of application to the material to be joined; however, cadmium containing silver brazes shall not be used.

Silver brazes are recommended for joining copper-base materials and dissimilar metals such as copper and stainless steel. The melting point must be greater than 811 K (1,000°F).

AWSC3.3 encompasses those procedures that should be followed in the design, manufacture, and inspection of brazed joints for critical components in order to ensure their reliability in service.

The procedures recommended represent the best current practice and are necessary to the control of brazed joint quality. These practices are applicable to all products and brazing processes. Whenever any or some of these practices are omitted when producing critical components, the omission should be the result of a rational decision, not the result of a lack of knowledge of the best practice.

### A-3.4 Branch Connections [See Para. GR-3.4.3(f)]

Each welded branch connection made to pipe in the form of a single connection, or in a header or manifold as a series of connections, must be designed to ensure that the strength of the pipeline system is not reduced,

taking into account the stresses in the remaining pipe wall due to the opening in the pipe or header, the shear stresses produced by the pressure acting on the area of the branch opening, and any external loadings due to thermal movement, weight, and vibration.

### A-3.5 Autogenous Weld Quality Criteria (See Para. GR-3.4.4) (23)

(a) *Acceptable.* Represents a flush O.D. and I.D. to the pipe surfaces [see Figure A-3.5-1, illustration (a)].

(b) *Fit-Up and Mismatch.* Pipe or tube shall be aligned so as to prevent hold-up volume areas that would contribute to contamination of the product. The maximum misalignment is 15% of nominal wall thickness [see Figure A-3.5-1, illustration (b)].

(c) *Concavity.* Maximum outside diameter concavity shall be limited to 10% of the nominal wall thickness over the entire circumference, with 15% of the nominal wall thickness permitted over a maximum total of 25% of the circumference [see Figure A-3.5-1, illustration (c)]. Maximum inside diameter concavity shall be limited to 10% of the nominal wall [see Figure A-3.5-1, illustration (d)]. In any case, O.D. and I.D. concavity shall be such that the wall thickness is not reduced to less than the design minimum thickness. In the case of two different wall thicknesses, maximum concavity will be governed by the smaller wall thickness.

(d) *Convexity.* Inside diameter convexity is limited to 10% of the nominal wall thickness. Outside diameter convexity is limited to 0.38 mm (0.015 in.) [see Figure A-3.5-1, illustration (f)].

(e) *Weld Penetration.* All welds shall be complete joint penetration to the I.D. of the wall thickness [see Figure A-3.5-1, illustrations (a) and (e)]. In the case of two different wall thicknesses, the weld shall penetrate to the I.D. of the thickest wall. Tack welds must be fully consumed by the welding process.

(f) *I.D. Weld Surface.* The I.D. weld surface shall not show the effects of a sugaring condition, but shall be smooth with gradual transition to the surface of the pipe I.D.

NOTE: For chromium-nickel materials, extreme discoloration of the weld deposit or heat affected zone shall not be allowed. Acceptable coloration includes light straw, light blue, or hueing.

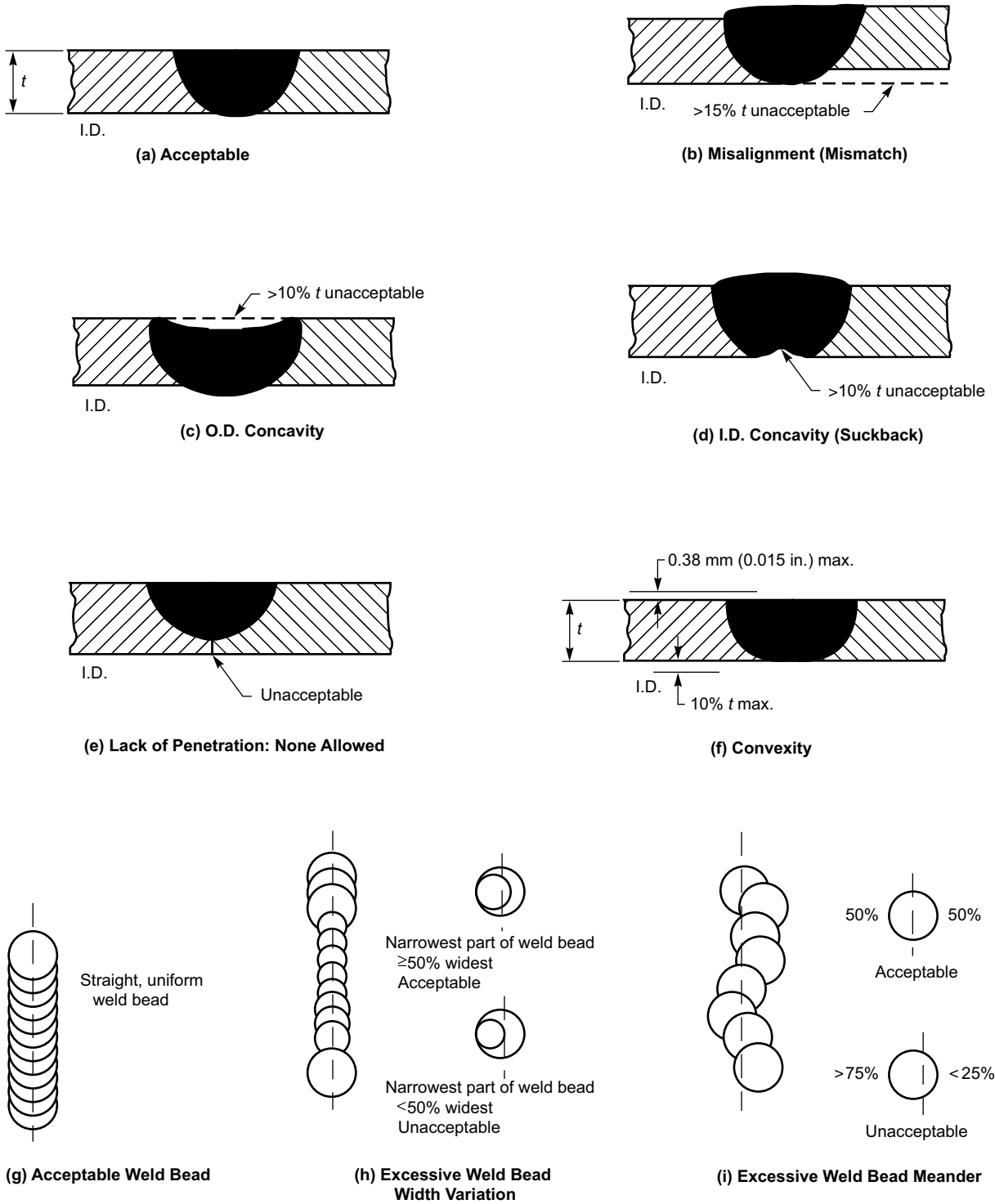
(g) *Tungsten Inclusions.* Tungsten inclusions shall meet the requirements of Tables IP-10.4.3-1 and IP-10.4.3-2.

(h) *Arc Strikes.* Arc strikes are not permitted. They may be removed by mechanical polishing, as long as the minimum design wall thickness is not compromised.

(i) *Outside Diameter Weld Bead Width.* The exterior of the weld bead shall be straight and uniform around the entire weld circumference [see Figure A-3.5-1, illustration (g)]. The minimum weld bead width shall not be less than 50% of the maximum weld bead width [see Figure A-3.5-1, illustration (h)]. The maximum weld bead meander shall

**Figure A-3.5-1**  
**Weld Quality Illustrations for Autogenous Welded Pipe or Tube**

(23)





be 25% of the weld bead width, measured as a deviation from the weld centerline [see Figure A-3.5-1, illustration (i)].

### A-3.6 Heat Treatment Considerations (See Para. GR-3.6)

Heat treatment temperatures listed in Table GR-3.6.1-1 for some P-No. 4 and P-No. 5 materials may be higher than the minimum tempering temperatures specified in the ASTM specifications for the base material. For higher strength normalized and tempered materials, there is consequently a possibility of reducing tensile properties of the base material, particularly if long holding times at the higher temperatures are used.

### A-3.7 Weld Joint Alignment for Cyclic Service

For cyclic service, pipe roundness and alignment of circumferential groove weld joints should be controlled to avoid excessive local bending stresses at welds. PFI ES-21 describes common practice. The engineering design should describe pipe roundness and alignment requirements beyond those required by the pipe specification and WPS.

## A-4 GENERAL INSPECTION, EXAMINATION, AND TESTING — SPECIAL CONSIDERATIONS (SEE PARA. GR-4.1)

A hydrogen-air-oxygen flame is colorless. Any visibility is caused by impurities. At reduced pressures, a pale blue or purple flame may be present. Detection of liquid hydrogen leaks by observation alone is not adequate. Although a cloud of frozen air and moisture may be visible, such a cloud is not a reliable sign of a hydrogen leak, because clouds of water vapor also rise from cold, exposed surfaces when no hydrogen leak is present.

## A-5 INDUSTRIAL PIPING DESIGN CONDITIONS (SEE CHAPTER IP-2)

Selection of pressures, temperatures, forces, and other conditions that may apply to the design of piping can be influenced by unusual requirements that should be considered when applicable. These include but are not limited to the following.

### A-5.1 Ambient Effects (See Para. IP-2.1.7)

LH<sub>2</sub> will eventually warm to the surroundings, giving a significant pressure rise if it is confined, as in a pipe between two valves. Considering GH<sub>2</sub> as an ideal gas, the pressure resulting from a trapped volume of LH<sub>2</sub> vaporizing and being heated to 21°C (70°F) is 85.8 MPa (12,452 psia). However, the pressure is 172 MPa (25,000 psia) when hydrogen compressibility is considered. A significant pressure increase will occur in a system

with only one phase present and the LH<sub>2</sub> experiences a temperature increase.

### A-5.2 Dynamic Effects (See Para. IP-2.1.8)

**A-5.2.1 Geysering.** Geysering is an effect that can occur in piping handling fluids at or near their boiling temperatures under conditions when rapid evolution of vapor within the piping causes rapid expulsion of liquid. In such cases, a pressure surge can be generated that may be destructive to the piping. (Geysering usually is associated with vertical pipelines, but may occur in inclined lines under certain conditions.)

#### A-5.2.2 Thermal Expansion and Contraction Effects

(a) Bowing during cooldown is an effect that can occur, usually in horizontal piping, on introduction of a fluid at or near its boiling temperature and at a flow rate that allows stratified two-phase flow, causing large circumferential temperature gradients and possibly unacceptable stresses at anchors, supports, guides, and within pipe walls. (Two-phase flow can also generate excessive pressure oscillations and surges that may damage the piping.)

(b) A steady cooldown flow rate of LH<sub>2</sub> or LN<sub>2</sub> that not only avoids stratified flow, but keeps the maximum cooldown stress within the allowable stress range, may not be possible for pipelines and flanges of certain sizes and materials. A pipeline in which this condition exists may be precooled with gas or slugs of liquid.

(c) Consideration should be given to cryogenic bowing in horizontal pipelines because of the stratified flow of a single liquid layer on the bottom of the pipe. Consideration shall be given to the large forces normally generated by bowing in designing pipe guides, main anchors, and intermediate anchors for bellows expansion joints. Cryogenic pipelines should be operated in regimes in which stratified flow does not occur.

**A-5.2.3 Effects of Support, Anchor, and Terminal Movements.** The use of pads or other means of pipe attachment at support points should be considered for piping systems subject to wear and pipe wall metal loss from relative movement between the pipe and its supports.

**A-5.2.4 Cyclic Effects.** Consideration should be given to the potential for thermal fatigue on surfaces exposed to the fluid when mixing fluids of different temperatures (e.g., cold droplets impinging on the pipe wall of a hot gas stream).

#### A-5.2.5 Air Condensation Effects

(a) Where there is a possibility of condensation occurring inside gaseous fluid piping, means should be considered to provide drainage from low areas to avoid damage from water hammer or corrosion.

(b) An uninsulated line containing LH<sub>2</sub> or cold hydrogen gas, such as a vent line, can be sufficiently cold [less than -183°C (-298°F) at 101.3 kPa (14.7 psia)] to condense air on the outside of the pipe. The condensed air, which can be enriched in oxygen to about 50%, must not be allowed to contact sensitive material or equipment. Materials not suitable for low temperatures, such as carbon steel, can become embrittled and fail. Moving parts and electronic equipment can be adversely affected. Condensed air must not be permitted to drip onto combustible materials, such as tar and asphalt (an explosive mixture can be created).

(c) In the particular case of liquid hydrogen, the possibility of air condensing on uninsulated cold parts shall be considered.

#### **A-6 PRESSURE DESIGN OF PIPING COMPONENTS — EXPANSION JOINTS (SEE PARA. IP-3.8.4)**

The following are specific considerations to be evaluated by the designer when specifying expansion joint requirements, in addition to the guidelines given in EJMA standards:

(a) susceptibility to stress corrosion cracking of the materials of construction, considering specific alloy content, method of manufacture, and final heat-treated condition.

(b) consideration of not only the properties of the hydrogen, but also the environment external to the expansion joint and the possibility of condensation or ice formation due to the operation of the bellows at a reduced temperature.

(c) consideration of specifying a minimum bellows or ply thickness. The designer is cautioned that requiring excessive bellows thickness may reduce the fatigue life of the expansion joint and increase end reactions. Multi-ply expansion joints and bellows should not be used in cryogenic service.

(d) accessibility of the expansion joint for maintenance and inspection.

(e) specification of installation procedures and shipping or preset bars so that the expansion joint will not be extended, compressed, or offset to compensate for improper alignment of piping, other than the intentional offset specified by the piping designer.

(f) need to request data from the expansion joint manufacturer, including

- (1) effective thrust area
- (2) lateral, axial, and rotational stiffness (spring constant)
- (3) calculated design cycle life under specified design conditions
- (4) friction force in hinges, tie rods, etc.
- (5) installed length and weight
- (6) requirements for additional support or restraint in the piping

(7) expansion joint elements that are designed to be uninsulated during operation

(8) certification of pressure-containing and/or restraining materials of construction

(9) maximum test pressure

(10) design calculations

#### **A-7 SERVICE REQUIREMENTS FOR VALVES AND SPECIALTY PIPING COMPONENTS (SEE PARA. IP-4.1)**

The following should be considered when selecting valves:

(a) Extended bonnet valves are recommended, where necessary, to establish a temperature differential between the valve stem packing and the fluid in the piping, to avoid packing leakage and external icing or other heat flux problems. The valve should be positioned to provide this temperature differential. Consideration should be given to possible packing shrinkage in low-temperature fluid service.

(b) The effect of external loads on valve operability and leak tightness should be considered.

(c) Possible packing shrinkage in low-temperature fluid service should be considered.

(d) Where LH<sub>2</sub> can be trapped (e.g., in double-seated valves) and subjected to heating and consequent expansion, means of pressure relief should be considered to avoid excessive pressure buildup.

(e) During helium leak tests of valves in the open position, leakage shall not exceed  $1 \times 10^{-8}$  mL/s when differential pressure between atmosphere and internal passages of the valves is greater than 100 kPa (14.6 psi).

#### **A-8 SPECIFIC INDUSTRIAL PIPING SYSTEMS — STOP VALVES IN PRESSURE RELIEF PIPING (SEE PARA. IP-7.2.1)**

If stop valves are located in pressure relief piping, and if any of these stop valves are to be closed while the equipment is in operation, an authorized person should be present. The authorized person should remain in attendance at a location where the operating pressure can be observed and should have access to means for relieving the system pressure in the event of overpressure. Before leaving the station, the authorized person should lock or seal the stop valves in the open position.

#### **A-9 INDUSTRIAL PIPING FABRICATION, ERECTION, AND ASSEMBLY**

##### **A-9.1 Flanged Joints (See Para. IP-9.13.2)**

**A-9.1.1 Surface.** The contact surface finish of the assembly face and the type of assembly affect gasket selection. The bolting should be adequate to produce the degree of gasket flow required for a pressure-tight seal. A



relatively rough surface finish requires heavier bolting to achieve the requisite gasket flow than a smooth surface finish. Concentrically serrated faces are preferred.

**A-9.1.2 Leaks.** Flanges should be leak-checked periodically. Flanges with soft gaskets in LH<sub>2</sub> systems should be retorqued periodically.

**A-9.1.3 Slip-On Flanges.** The need for venting the space between the welds in double-welded, slip-on flanges should be considered for fluid services (including vacuum) that require leak testing of the inner fillet weld, or when fluid handled can diffuse into the enclosed space, resulting in possible failure.

**A-9.1.4 Gaskets.** The effect of flange facing finish should be considered in gasket material selection. Metallic gaskets have been used successfully with raised-face flanges for pressures to 20.6 MPa (3,000 psig). A tongue-and-groove flange is desirable for most gasket materials for higher pressures. A confining flange is mandatory if a plastic such as Teflon is used. Twenty-five percent glass-filled Teflon should be used for flanges that are not seal welded.

- (23) **A-9.1.5 Large Diameter Tubes.** Flanged or fusion-welded joints shall be the standard rule for steel tubes larger than 25 mm (1 in.) in diameter and for pressures greater than 860 kPa (125 psig). It may be necessary in some cases involving pressures higher than 860 kPa (125 psig) and tubes larger than 25 mm (1 in.) to use flared fittings. These cases are to be considered special and shall be submitted to engineering design for approval. Use of flared fittings requires high-quality tools and workmanship. For tubes, power machines are necessary to obtain the required quality of flare.

## A-9.2 Threaded Joints (See Para. IP-9.14)

Threaded joints with a suitable thread seal are acceptable for use in gaseous hydrogen systems, but are to be avoided in liquid hydrogen systems. Consideration should be given to back-welding threaded joints inside buildings for gaseous hydrogen service. If threaded joints must be used in liquid hydrogen systems, the male and female threads should be tinned with a 60% lead and 40% tin solder, then heated to provide a soldered joint with pipe thread strength.

## A-9.3 Bimetallic Transition Joints (See Para. IP-9.16)

Transition joints are used to join dissimilar metals where flanged, screwed, or threaded connections are not practical. They are used when fusion welding of two dissimilar metals forms interfaces that are deficient in mechanical strength and the ability to keep the system leak-tight. Transition joints consist of a bimetallic composite, a stainless steel, and a particular kind of aluminum

bonded together by some proprietary process. Some of the types in use throughout the cryogenic industry are friction- or inertia-welded bond, roll-bonded joint, explosion-bonded joint, and braze-bonded joint.

## A-9.4 Cleaning of Piping (See Para. IP-9.18)

Following are some general considerations that may be evaluated in determining the need for cleaning of piping:

(a) requirements of the hydrogen service, including possible contaminants and corrosion products during fabrication, assembly, storage, erection, and testing

(b) for low-temperature service, removal of moisture, oil, grease, and other contaminants to prevent sticking of valves or blockage of piping and small cavities

## A-10 INDUSTRIAL PIPING INSPECTION, EXAMINATION, AND TESTING

### A-10.1 Special Provisions for Examination (See Para. IP-10.4)

(a) The piping and components should be examined before and during installation for the integrity of seals and other means of protection provided to maintain the special cleanliness or dryness requirements specified for LH<sub>2</sub> systems.

(b) Protective coverings should be examined for any damage or omission that would allow the component or piping to become wetted or contaminated beyond the limits specified in the engineering design.

(c) Components specified to be maintained under positive gas pressure should be examined to ensure conformance to the requirements.

### A-10.2 Hydrostatic Leak Test

**A-10.2.1 Test Fluid (See Para. IP-10.6.1).** Consideration should be given to susceptibility to microbiologically influenced corrosion (MIC). This condition is especially prevalent in no-flow, high-moisture environments. Internal MIC may also depend on the characteristics of the treated or untreated test fluid. Internal MIC may be lessened or possibly eliminated by properly draining and drying systems and/or by proper selection of test fluid.

**A-10.2.2 Pneumatic Leak Test (See Para. IP-10.7.1).** The pneumatic test may be used in lieu of the hydrostatic test for hydrogen systems designed or supported so they cannot safely be filled with liquid, or if the vessel or system cannot be readily dried or is to be used in services in which traces of the testing liquid cannot be tolerated. The substitution requires that the parts of the system, when possible, are previously tested by hydrostatic pressure. The pneumatic test pressure should be 1.25 times the maximum allowable working pressure.

**A-11 PREHEATING FOR PIPELINE (SEE [PARA. PL-3.19](#))**

Pipeline that has been used in sour gas service shall be heated for at least 20 min at 204°C (400°F) or higher to drive off any hydrogen in the metal. Heating shall be done

just prior to welding. This heating should be in addition to and immediately preceding any preheating specified in the welding procedure for new pipeline.

# NONMANDATORY APPENDIX B

## ALTERNATIVE RULES FOR EVALUATING STRESS RANGE

### B-1 GENERAL

This Appendix provides alternative rules for evaluating the stress range in piping systems. It considers stresses at operating conditions, including displacement and sustained loads, rather than displacement stress range only. The method is more comprehensive than that provided in Chapter IP-6 and is more suitable for computer analysis of piping systems, including nonlinear effects such as pipes lifting off of supports.

In the application of these alternative rules, all of the provisions of Chapter IP-6 apply, except those that are modified by this Appendix.

### B-2 LIMITS OF CALCULATED STRESSES DUE TO SUSTAINED LOADS AND DISPLACEMENT STRAINS

Replace para. IP-2.2.10(d) with the following. Footnotes and nomenclature are the same as found in para. IP-2.2.10(d).

(d) *Allowable Operating Stress Limit.* The greater of the maximum operating stress and maximum operating stress range,  $S_{om}$ , in a piping system [see para. IP-6.1.5(d)] shall not exceed the allowable operating stress limit,  $S_{oA}$  [see paras. IP-6.1.3(c) and IP-6.1.4(d)] calculated by eq. (B1a). The operating stress is the calculated stress at any operating condition, including pressure, weight, and other sustained loads, and displacement. Occasional loads (see para. IP-2.2.10) are not required to be included.

The operating stress range is the range of stress between any two operating conditions, including the ranges between operating conditions and a sustained case with the piping at ambient temperature.

$$S_{oA} = 1.25f(S_c + S_h) \quad (B1a)$$

When the computed stress range varies, whether from thermal expansion or other conditions,  $S_E$  is defined as the greatest computed operating stress range. The value of  $N$  in such cases can be calculated by eq. (B1d)

$$N = N_E + \sum (r_i^5 N_i) \text{ for } i = 1, 2, \dots, n \quad (B1d)$$

### B-3 FLEXIBILITY STRESSES

Paragraph IP-6.1.5(d) is applicable, except that subparagraph (1) and eq. (17) are replaced with the following:

(1) The stress due to bending, torsion, and axial loads shall be computed using the reference modulus of elasticity at 21°C (70°F),  $E_a$ , except as provided in para. IP-6.1.3(b)(2)(-d), and then combined in accordance with eq. (B17a) to determine the operating stress,  $S_o$ , and eq. (B17b) to determine the operating stress range,  $S_E$ .  $S_{om}$  is the greater of the maximum operating stress,  $S_o$ , and maximum operating stress range,  $S_E$ , which shall not exceed the allowable stress,  $S_{oA}$ , in para. B-2(d).  $S_E$  is the maximum operating stress range, which is used in calculating  $N$  in para. B-2(d) and in determining if the pipe is under severe cyclic conditions.

$$S_o = \sqrt{(|S_a| + S_b)^2 + 4S_t^2} \quad (B17a)$$

$$S_E = \sqrt{(|S_a| + S_b)^2 + 4S_t^2} \quad (B17b)$$

The definitions in para. IP-6.1.5(d) apply, with the following additional definitions:

$A_p$  = cross-sectional area of the pipe

$F_a$  = axial force, including that due to internal pressure

$i_a$  = axial force stress intensification factor. In the absence of more applicable data,  $i_a = 1.0$  for elbows and  $i_a = i_o$  from ASME B31.3, Appendix D for other components.

$S_a$  = stress due to axial force =  $i_a F_a / A_p$

### B-4 REQUIRED WELD QUALITY ASSURANCE

Paragraph IP-6.1.5(e) applies, except that  $S_{oA}$  replaces  $S_A$ .

### B-5 REACTIONS

Replace para. IP-6.1.6 with the following: Reaction forces and moments used to design restraints and supports for a piping system, and to evaluate the effects of piping displacement on connected equipment, shall be based on the maximum load from operating conditions, including weight, pressure, and other sustained loads; thermal displacement; and, where applicable, occasional loads. The reactions shall be calculated using the modulus of elasticity at the temperature of the condition,  $E_m$  ( $E_a$  may be used instead of  $E_m$  when it provides a more conservative result). The temperature of the condition may differ in different locations within the piping system. When cold spring is used in the piping system,

experience has shown that it cannot be fully assured. Therefore, the reactions shall be computed both with the assumption that only two-thirds of the design cold spring is present and with four-thirds of the design cold spring present. If it is necessary to determine the reactions at ambient temperature, the designer shall consider loads at that condition, including the design cold spring and self-springing of piping. Self-springing may occur if the operating stress in the piping system exceeds the yield strength of the material or if the

piping operates at temperatures in the creep range of the material.

#### **B-6 MAXIMUM REACTIONS FOR SIMPLE SYSTEMS**

Paragraph IP-6.1.6(a) is not applicable.

#### **B-7 MAXIMUM REACTIONS FOR COMPLEX SYSTEMS**

Paragraph IP-6.1.6(b) is not applicable.

# NONMANDATORY APPENDIX C

## RECOMMENDED PRACTICES FOR PROOF TESTING OF PIPELINES IN PLACE

### (23) C-1 INTRODUCTION

The purpose of this Appendix is to cite some of the important steps that should be taken in the proof testing of in-place pipelines. It is intended to provide basic guidelines only. [Paragraph C-2.8](#) of this recommended practice is used for the determination of the pressure at which the pipe actual yield strength is achieved in testing. All pressure tests shall be conducted with due regard for the safety of people and property. When test pressure is above 2 800 kPa (400 psig), appropriate precautions shall be taken to keep people not engaged in the testing operations out of the testing area while conducting the test.

### C-2 HYDROSTATIC TESTING

#### C-2.1 Selection of Test Sections and Test Sites

The pipeline may need to be divided into sections for testing to isolate areas with different test pressure requirements or to obtain maximum and minimum test pressures due to hydrostatic head differential. The elevation at the test site, the high point and low point of the isolated area, must be known to maintain the specified pressure at the maximum and minimum elevations.

#### C-2.2 Water Source and Water Disposal

A water source, as well as location(s) for water disposal, should be selected well in advance of the testing. Federal, state, and local regulations should be checked to ensure compliance with respect to usage and/or disposal of the water. In disposing of the water after testing, care should be taken to prevent damage to crops and excessive erosion or contamination of streams, rivers, or other water bodies, including groundwater.

#### C-2.3 Ambient Conditions

Hydrostatic testing in low-temperature conditions may require the following:

- (a) heating of the test medium.
- (b) the addition of freeze-point depressants. Caution should be exercised in the handling of freeze-point depressants during tests. Disposal of freeze-point depressants must be carefully planned and executed.

#### C-2.4 Filling

Filling is normally done with a high-volume centrifugal pump or pumps. Filling should be continuous and be done behind one or more squeegees or spheres, to minimize the amount of air in the line. The progress of filling should be monitored by metering the water pump into the pipeline and calculating the volume of line filled. If necessary, a period of temperature stabilization between the ground and fill water should be provided.

#### C-2.5 Pressure Pump

Normally, a positive displacement reciprocating pump is used for pressurizing the pipeline during testing. The flow capacity of the pump should be adequate to provide a reasonable pressurizing rate. The pressure rating of the pump must be higher than the anticipated maximum test pressure.

#### C-2.6 Test Heads, Piping, and Valves

The design pressure of the test heads and piping, and the rated pressure of hoses and valves in the test manifold, shall be no less than the anticipated test pressure. All equipment should be inspected prior to the test to determine that it is in satisfactory condition.

#### C-2.7 Pressurization

The following is a sequence for pressurization:

(a) Raise the pressure in the section to not more than 80% of anticipated test pressure, and hold for a time period to determine that no major leaks exist.

(b) During this time period, monitor the pressure and check the test section for leakage. Repair any major leaks that are found.

(c) After the hold time period, pressurize at a uniform rate to the test pressure. Monitor for deviation from a straight line by use of pressure-volume plots (logs or automatic plotter).

(d) When the test pressure is reached and stabilized from pressuring operations, a hold period may commence. During this period, test medium may be added as required to maintain the minimum test pressure.

### C-2.8 Determination of Pressure Required to Produce Yielding

Yield strength determined in this manner is actual yield strength rather than specified minimum yield strength (SMYS). Use of this value may be limited by the Code or applicable government regulations.

**C-2.8.1** If monitoring deviation from a straight line with graphical plots, an accurate plot of pressure versus the volume of water pumped into the line may be made either by hand or automatic plotter. To make a hand plot, the pump strokes are counted to determine volume and plotted against pressure readings. The plot should be started at a pressure low enough to establish accurately the straight-line portion of the pressure-volume plot. The points should be plotted frequently enough so that deviation from the straight-line portion can be detected readily. The deviation from the straight line is the start of the nonlinear portion of the pressure-volume plot and indicates that the elastic limit of some of the pipe within the section has been reached.

**C-2.8.2** Yield for unidentified or used pipe is determined by using the pressure at the highest elevation within a test section, at which the number of pump strokes (measured volume) per increment of pressure rise becomes twice the number of pump strokes (measured volume) per increment of pressure rise that was required during the straight-line part of the pressure-volume plot and before any deviation occurs.

**C-2.8.3** For control of maximum test pressure when hoop stress levels exceed 100% SMYS within a test section, one of the following measures may be used:

(a) The pressure at which the number of pump strokes (measured volume) per increment of pressure rise becomes twice the number of pump strokes (measured volume) per increment of pressure rise that was required during the straight-line part of the pressure-volume plot before any deviation occurs.

(b) The pressure shall not exceed the pressure occurring when the number of pump strokes (measured volume) taken after deviation from the straight-line part of the pressure-volume plot, times the volume per stroke, is equal to 0.002 times the test section fill volume at atmospheric pressure. This represents the average behavior of the test section. Individual pipe lengths may experience greater or smaller expansion, based on their respective mechanical properties.

### C-2.9 Leak Testing

If leakage is indicated during the hold period, the pressure may be reduced while locating the leak. After the leak is repaired, a new hold period must be started at full test pressure.

### C-2.10 Testing Records

(a) The operating company should maintain in its file, for the useful life of each pipeline and main, records showing the following:

- (1) test medium
- (2) test pressure
- (3) test duration
- (4) test date
- (5) pressure recording chart and pressure log
- (6) pressure versus volume plot (if applicable)
- (7) pressure at high and low elevations
- (8) elevation at point test pressure measured
- (9) person(s) conducting test, operator, and testing contractor, if utilized
- (10) environmental factors (ambient temperature, raining, snowing, windy, etc.)
- (11) manufacturer (pipe, valves, etc.)
- (12) pipe specifications (SMYS, diameter, wall thickness, etc.)
- (13) clear identification of what is included in each test section
- (14) description of any leaks or failures and their disposition

(b) The above records shall be reviewed to ensure that the requirements of this Code have been met.

## C-3 PNEUMATIC TESTING

### C-3.1 Pneumatic Leak Test

Testing of pipelines may be done with air or inert gas. Pneumatic testing involves the hazard of released energy stored in compressed gas. Particular care must therefore be taken to minimize the chance of brittle failure during a pneumatic leak test. Test temperature is important in this regard and must be considered when the designer chooses the material of construction. Suitable steps shall be taken to keep persons not working on the testing operations out of the testing area when the hoop stress is raised above 20% of the specified minimum yield strength. Additionally, limitations of hoop stress levels are imposed due to concern over the stored energy release in the event of a failure during the test.

### C-3.2 Pressure Relief Device

A pressure relief device shall be provided, having a set pressure not higher than the test pressure plus the lesser of 345 kPa (50 psi) or 10% of the test pressure.

### C-3.3 Test Pressure

The test pressure shall be 110% of MAOP, except that the maximum hoop stress permissible during testing shall be

- (a) 50% of specified minimum yield strength for Location Classes 1 through 3

(b) 40% of specified minimum yield strength for Location Class 4

### C-3.4 Procedure

The pressure shall be gradually increased until a gage pressure that is the lesser of one-half the test pressure or 170 kPa (25 psi) is attained, at which time a preliminary check shall be made, including examination of joints. Thereafter, the pressure shall be gradually increased in steps until the test pressure is reached, holding the pressure at each step long enough to equalize piping strains. The pressure shall then be reduced to the design pressure before examining for leakage.

### C-3.5 Testing Records

(a) The operating company should maintain in its file, for the useful life of each pipeline and main, records showing the following:

- (1) test medium
  - (2) test pressure
  - (3) test duration
  - (4) test date
  - (5) pressure recording chart and pressure log
  - (6) person(s) conducting test, operator, and testing contractor, if utilized
  - (7) environmental factors (ambient temperature, raining, snowing, windy, etc.)
  - (8) manufacturer (pipe, valves, etc.)
  - (9) pipe specifications (SMYS, diameter, wall thickness, etc.)
  - (10) clear identification of what is included in each test section
  - (11) description of any leaks or failures and their disposition
- (b) The above records shall be reviewed to ensure that the requirements of this Code have been met.



## NONMANDATORY APPENDIX D ESTIMATING STRAIN IN DENTS

### D-1 STRAIN

Strain in dents may be estimated using data from deformation in-line inspection (ILI) tools or from direct measurement of the deformation contour. Direct measurement techniques may consist of any method capable of describing the depth and shape terms needed to estimate strain. The strain estimating techniques may differ depending on the type of data available. Interpolation or other mathematical techniques may be used to develop surface contour information from ILI or direct measurement data. Although a method for estimating strain is described herein, it is not intended to preclude the use of other strain estimating techniques. See also [Figure D-1-1](#).

### D-2 ESTIMATING STRAIN

$R_0$  is the initial pipe surface radius, equal to one-half the nominal pipe O.D. Determine the indented O.D. surface radius of curvature,  $R_1$ , in a transverse plane through the dent. The dent may only partially flatten the pipe such that the curvature of the pipe surface in the transverse plane is in the same direction as the original surface curvature, in which case  $R_1$  is a positive quantity. If the dent is reentrant, meaning the curvature of the pipe surface in the transverse plane is actually reversed,  $R_1$  is a negative quantity. Determine the radius of curvature,  $R_2$ , in a longitudinal plane through the dent. The term  $R_2$  as used herein will generally always be a negative quantity. Other dimensional terms are the wall thickness,  $t$ ; the dent depth,  $d$ ; and the dent length,  $L$ .

(a) Calculate the bending strain in the circumferential direction as

$$\epsilon_1 = \frac{1}{2}t \left( \frac{1}{R_0} - \frac{1}{R_1} \right)$$

(b) Calculate the bending strain in the longitudinal direction as

$$\epsilon_1 = -\frac{1}{2} \left( \frac{t}{R_2} \right)$$

(c) Calculate the extensional strain in the longitudinal direction as

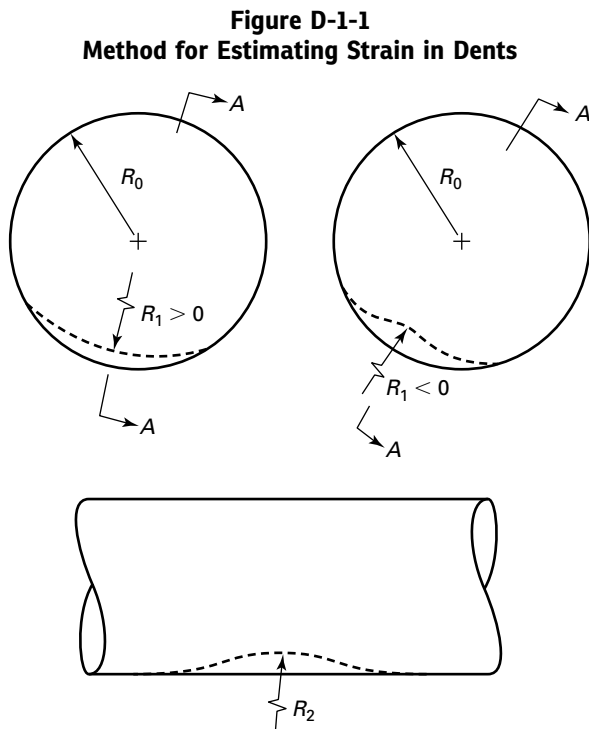
$$\epsilon_1 = \frac{1}{2} \left( \frac{d}{L} \right)^2$$

(d) Calculate the strain on the inside pipe surface as

$$\epsilon_1 = \left[ \epsilon_1^2 - \epsilon_1(\epsilon_2 + \epsilon_3) + (\epsilon_2 + \epsilon_3)^2 \right]^{1/2}$$

and the strain on the outside pipe surface as

$$\epsilon_1 = \left[ \epsilon_1^2 + \epsilon_1(-\epsilon_2 + \epsilon_3) + (-\epsilon_2 + \epsilon_3)^2 \right]^{1/2}$$



## NONMANDATORY APPENDIX E

### SAMPLE CALCULATIONS FOR BRANCH REINFORCEMENT IN PIPING

#### (23) E-1 INTRODUCTION

The examples in this Appendix are intended to illustrate the application of the rules and definitions in [para. IP-3.4.2](#) for welded branch connections. The examples are given in U.S. Customary units only.

#### E-2 EXAMPLE 1

An NPS 8 run (header) in a piping system has an NPS 4 branch at right angles (see [Figure E-2-1](#)). Both pipes are Schedule 40 API 5L Grade A seamless. The design conditions are 300 psig at 400°F. The fillet welds at the crotch are minimum size in accordance with [para. IP-3.4](#). A corrosion allowance of 0.10 in. is specified. Is additional reinforcement necessary?

#### Solution

From [Mandatory Appendix IX](#),  $S = 16.0$  ksi for API 5L Grade A ([Table IX-1A](#));  $E = 1.00$  per API 5L seamless ([Table IX-3A](#)).

$$T_h = 0.322(0.875) = 0.282 \text{ in.}$$

$$T_b = 0.237(0.875) = 0.207 \text{ in.}$$

$$\begin{aligned} L_4 &= 2.5(0.282 - 0.1) = 0.455 \text{ in.} \\ &\text{or } 2.5(0.207 - 0.1) + 0 = 0.268 \text{ in.,} \\ &\text{whichever is less} \\ &= 0.268 \text{ in.} \end{aligned}$$

$$d_1 = [4.5 - 2(0.207 - 0.1)]/\sin 90 \text{ deg} = 4.286 \text{ in.}$$

$$\begin{aligned} d_2 &= (0.207 - 0.1) + (0.282 - 0.1) \\ &\quad + 4.286/2 = 2.432 \text{ in.} \end{aligned}$$

Use  $d_1$  or  $d_2$ , whichever is greater.

$$d_1 = 4.286 \text{ in.}$$

$$t_h = \frac{300(8.625)}{2(16,000)(1.00) + 2(0.4)(300)} = 0.080 \text{ in.}$$

$$t_b = \frac{300(4.500)}{2(16,000)(1.00) + 2(0.4)(300)} = 0.042 \text{ in.}$$

$$\begin{aligned} t_c &= 0.7(0.237) = 0.166 \text{ in. or } 0.25, \text{ whichever is less} \\ &= 0.166 \text{ in.} \end{aligned}$$

Minimum leg dimension of fillet weld =  $0.166/0.707 = 0.235$  in. Thus, the required area

$$A_1 = (0.080)(4.286)(2 - \sin 90 \text{ deg}) = 0.343 \text{ in.}^2$$

The reinforcement area in run wall

$$\begin{aligned} A_2 &= (4.286)(0.282 - 0.08 - 0.10) \\ &= 0.437 \text{ in.}^2 \end{aligned}$$

in branch wall

$$A_3 = 2(0.268)[(0.207 - 0.042) - 0.10] = 0.035 \text{ in.}^2$$

in branch welds

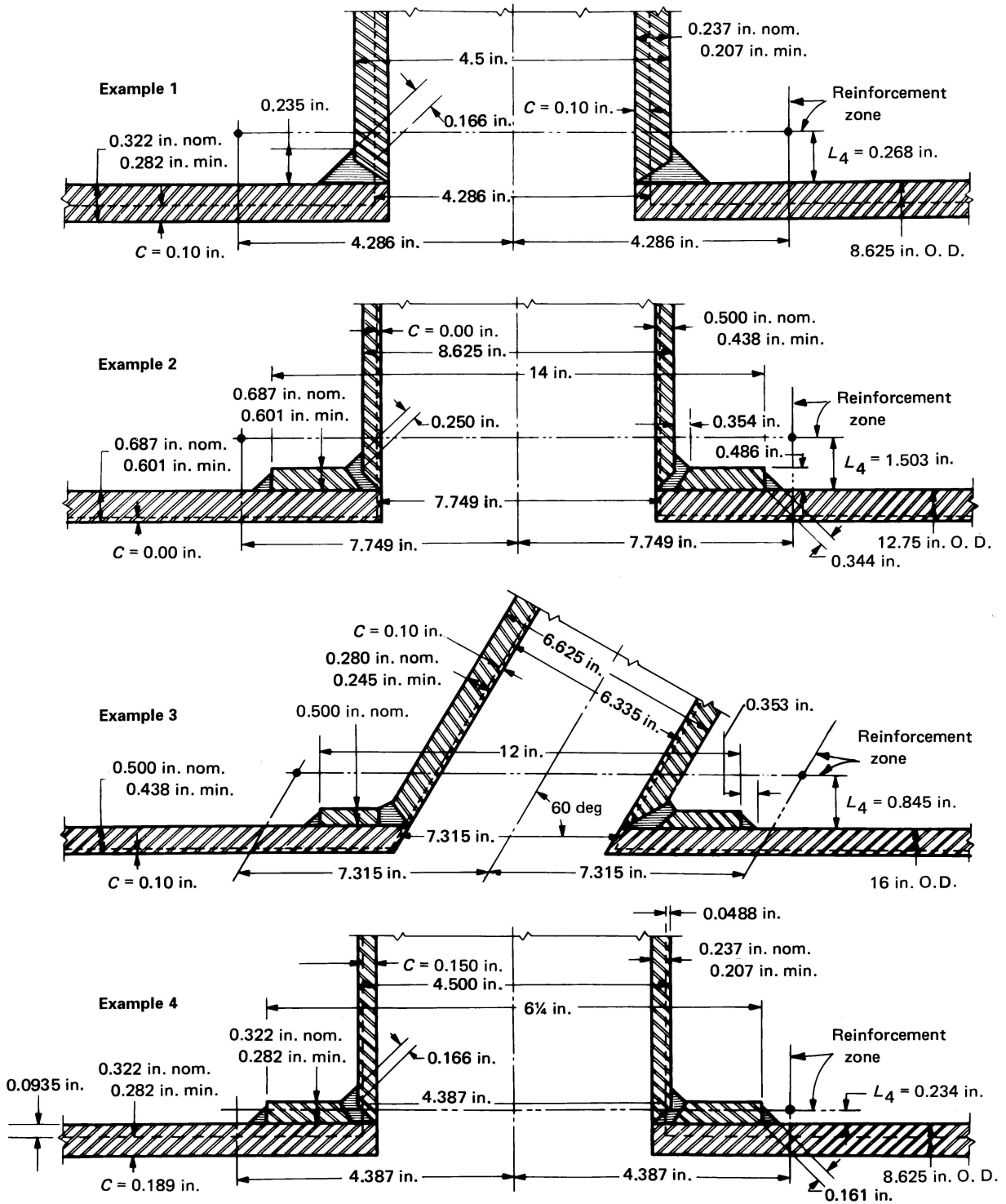
$$A_4 = 2\left(\frac{1}{2}\right)(0.235)^2 = 0.055 \text{ in.}^2$$

The total reinforcement area =  $0.527 \text{ in.}^2$ . This is more than  $0.343 \text{ in.}^2$ , so that no additional reinforcement is required to sustain the internal pressure.

#### E-3 EXAMPLE 2

There is an NPS 8 branch at right angles to an NPS 12 header ([Figure E-2-1](#)). Both run and branch are of aluminum alloy Schedule 80 ASTM B241 6061-T6 seamless pipe. The connection is reinforced by a ring 14 in. O.D. (measured along the run) cut from a piece of NPS 12 Schedule 80 ASTM B241 6063-T6 seamless pipe and opened slightly to fit over the run pipe. Allowable stresses for welded construction apply in accordance with [Mandatory Appendix IX, Table IX-1A, Note \(28\)](#). The fillet welds have the minimum dimensions permitted in [para. IP-3.4](#). A zero corrosion allowance is specified. What is the maximum permissible design pressure if the design temperature is  $-320^\circ\text{F}$ ?

**Figure E-2-1**  
**Illustrations for Examples in Nonmandatory Appendix E**



**Solution**

From [Table IX-1A](#),  $S = 8.0$  ksi for Grade 6061-T6 (welded) pipe and  $S = 5.7$  ksi for Grade 6063-T6 (welded) pad, both at  $-320^\circ\text{F}$ . From [Table IX-3A](#),  $E = 1.00$  for ASTM B241.

Leg dimensions of welds

$$\frac{t_c}{0.707} = \frac{0.250}{0.707} = 0.354 \text{ in.}$$

$$\frac{0.5(0.687)}{0.707} = 0.486 \text{ in.}$$

$$T_h = 0.687(0.875) = 0.601 \text{ in.}$$

$$T_b = 0.500(0.875) = 0.438 \text{ in.}$$

$$T_r = 0.687(0.875) = 0.601 \text{ in.}$$

$$L_4 = 2.5(0.601 - 0.00) = 1.503 \text{ in.}$$

[This is smaller than  $2.5(0.438 - 0.00) + 0.601 = 1.695$  in.]

$$d_2 = d_1 = 8.625 - 2(0.438 - 0.00) = 7.749 \text{ in.}$$

$$t_h = \frac{12.75P}{2(8,000)(1.00) + 2(0.4)(P)}$$

$$t_b = \frac{8.625P}{2(8,000)(1.00) + 2(0.4)(P)}$$

Using the symbol

$$q = \frac{P}{16,000 + 0.8P}$$

we can briefly write

$$t_h = 12.75q \text{ and } t_b = 8.625q$$

The required area

$$A_1 = 7.749t_h = 98.80q$$

The reinforcement area in run wall

$$\begin{aligned} A_2 &= 7.749(0.601 - 12.75q - 0.00) \\ &= 4.657 - 98.80q \end{aligned}$$

in branch wall

$$\begin{aligned} A_3 &= 2(1.503)(0.438 - 8.625q - 0.00) \\ &= 1.317 - 25.93q \end{aligned}$$

in ring

$$A_4 = 0.601(14 - 8.625)(5,700/8,000) = 2.302$$

in fillet welds

$$A_4 = 2\left(\frac{1}{2}\right)(0.354)^2 + 2\left(\frac{1}{2}\right)(0.486)^2 = 0.362$$

The total reinforcement area =  $8.638 - 124.73q$ .

At the maximum permissible normal operating pressure, the required area and the reinforcement area are equal; thus

$$\begin{aligned} 98.80q &= 8.638 - 124.73q \\ 223.53q &= 8.638 \\ q &= 0.0386 \end{aligned}$$

But also

$$q = \frac{P}{16,000 + 0.8P}$$

Thus

$$\begin{aligned} P &= 0.0386(16,000 + 0.8P) = 618.3 + 0.0309P \\ 0.961P &= 618.3 \\ P &= 643.1 \text{ psig} \end{aligned}$$

which is the maximum permissible design pressure.

**E-4 EXAMPLE 3**

An NPS 6 Schedule 40 branch has its axis at a 60 deg angle to the axis of an NPS 16 Schedule 40 run (header) in a piping system (see [Figure E-2-1](#)). Both pipes are API 5L Grade A seamless. The connection is reinforced with a ring 12 in. O.D. (measured along the run) made from  $\frac{1}{2}$  in. SA-/A285 Grade C plate. All fillet welds are equivalent to 45 deg fillet welds with  $\frac{3}{8}$  in. legs. Corrosion allowance = 0.10 in. The design pressure is 500 psig at  $650^\circ\text{F}$ . Is the design adequate for the internal pressure?

**Solution**

From [Mandatory Appendix IX](#),  $S = 14.5$  ksi for API 5L Grade A and SA-/A285 Grade C (see [Table IX-1A](#));  $E = 1.00$  for API 5L seamless (see [Table IX-3A](#)).

$$T_h = 0.500(0.875) = 0.438 \text{ in.}$$

$$T_b = 0.280(0.875) = 0.245 \text{ in.}$$

$$T_r = 0.500 \text{ in.}$$

$$L_4 = 2.5(0.245 - 0.10) + 0.500 = 0.8625$$

This is greater than  $2.5(0.438 - 0.10) = 0.845$  in.

$$t_h = \frac{500(16)}{2(14,500)(1.00) + 2(0.4)(500)} = 0.272 \text{ in.}$$

$$t_b = \frac{500(6.625)}{2(14,500)(1.00) + 2(0.4)(500)} = 0.113 \text{ in.}$$

$$d_2 = d_1 = \frac{6.625 - 2(0.245 - 0.10)}{\sin 60^\circ} = \frac{6.335}{0.866} = 7.315 \text{ in.}$$

The required area

$$A_1 = (0.272)(7.315)(2 - 0.866) = 2.256 \text{ in.}^2$$

The reinforcement area in run wall

$$A_2 = 7.315(0.438 - 0.272 - 0.10) = 0.483 \text{ in.}^2$$

in branch wall

$$A_3 = 2 \left( \frac{0.845}{0.866} \right) (0.245 - 0.113 - 0.10) = 0.062 \text{ in.}^2$$

in ring

$$A_4 = 0.500 \left( 12 - \frac{6.625}{0.866} \right) = 2.175 \text{ in.}^2$$

in fillet welds

$$A_4 = 4 \left( \frac{1}{2} \right) \left( \frac{3}{8} \right)^2 = 0.281 \text{ in.}^2$$

The total reinforcement area = 3.001 in.<sup>2</sup> This total is greater than 2.256 in.<sup>2</sup>, so that no additional reinforcement is required.

## E-5 EXAMPLE 4

An NPS 8 run (header) in a piping system has an NPS 4 branch at right angles (see [Figure E-2-1](#)). Both pipes are Schedule 40 API 5L Grade A seamless. The design conditions are 350 psig at 400°F. It is assumed that the piping system is to remain in service until all metal thickness, in both branch and run, in excess of that required by [eq. \(3a\)](#) of [para. IP-3.2.1\(a\)](#) has corroded away so that area  $A_2$  as defined in [para. IP-3.4.2\(c\)\(1\)](#) is zero. What reinforcement is required for this connection?

### Solution

From [Mandatory Appendix IX](#),  $S = 16.0$  ksi for API 5L Grade A (see [Table IX-1A](#));  $E = 1.00$  for API 5L seamless (see [Table IX-3A](#)).

$$t_h = \frac{350(8.625)}{2(16,000)(1.00) + 2(0.4)(350)} = 0.0935 \text{ in.}$$

$$t_b = \frac{350(4.500)}{2(16,000)(1.00) + 2(0.4)(350)} = 0.0488 \text{ in.}$$

$$d_1 = 4.500 - 2(0.0488) = 4.402 \text{ in.}$$

Required reinforcement area

$$A_1 = 0.0935(4.402) = 0.412 \text{ in.}^2$$

Try fillet welds only

$$L_4 = 2.5(0.0935) = 0.234 \text{ in.}$$

$$\text{or } 2.5(0.0488) = 0.122 \text{ in.}$$

Use 0.122 in.

Due to limitation in the height at the reinforcement zone, no practical fillet weld size will supply enough reinforcement area; therefore, the connection must be further reinforced. Try a 6¼ in. O.D. reinforcing ring (measured along the run). Assume the ring to be cut from a piece of NPS 8 Schedule 40 API 5L Grade A seamless pipe and welded to the connection with minimum size fillet welds.

Minimum ring thickness

$$T_r = 0.322(0.875) = 0.282 \text{ in.}$$

$$\text{New } L_4 = 2.5(0.0488) + 0.282 = 0.404 \text{ in.}$$

$$\text{or } 2.5(0.0935) = 0.234 \text{ in.}$$

Use 0.234 in.

Reinforcement area in the ring (considering only the thickness within  $L_4$ )

$$X_1 = 0.234(6.25 - 4.5) = 0.410 \text{ in.}^2$$

$$\text{Leg dimension of weld} = \frac{0.5(0.322)}{0.707} = 0.228 \text{ in.}$$

Reinforcement area in fillet welds

$$X_2 = 2 \left( \frac{1}{2} \right) (0.228)^2 = 0.052 \text{ in.}^2$$

Total reinforcement area

$$A_4 = X_1 + X_2 = 0.462 \text{ in.}^2$$

This total reinforcement area is greater than the required area; therefore, a reinforcing ring 6¼ in. O.D., cut from a piece of NPS 8 Schedule 40 API 5L Grade A seamless pipe and welded to the connection with minimum size fillet welds would provide adequate reinforcement for this connection.

## E-6 EXAMPLE 5 (NOT ILLUSTRATED)

An NPS 1½ Class 3000 forged steel socket welding coupling has been welded at right angles to an NPS 8 Schedule 40 run (header) in hydrogen service, using a weld conforming to [Figure GR-3.4.9-1](#), illustration (c). The run is ASTM A53 Grade B seamless pipe. The design pressure is 400 psi and the design temperature is 450°F. The corrosion allowance is 0.10 in. Is additional reinforcement required?

### Solution

No. According to [paras. IP-3.4\(a\)\(1\)](#), [paras. IP-3.4\(a\)\(2\)](#), and [IP-3.4.1](#), the design is adequate to sustain the internal pressure and no calculations are necessary. It is presumed, of course, that calculations have shown the run pipe to be

satisfactory for the service conditions according to eqs. (2) and (3) in Chapter IP-3.

# NONMANDATORY APPENDIX F

## WELDED BRANCH CONNECTIONS AND EXTRUDED HEADERS IN PIPELINE SYSTEMS

### (23) F-1 DEFINITIONS AND LIMITATIONS

Definitions and limitations applicable to [Figures F-1-1](#) through [F-1-4](#) are as follows. The examples in this Appendix are given in U.S. Customary units only.

$D$  = outside diameter of run

$d$  = outside diameter of branch pipe

$D_c$  = corroded internal diameter of run

$d_c$  = corroded internal diameter of branch pipe

$D_o$  = corroded internal diameter of extruded outlet measured at the level of the outside surface of run

$h_o$  = height of the extruded lip. This must be equal to or greater than  $r_o$ , except as shown in limitation (b) of  $r_o$  below.

$L$  = height of the reinforcement zone

$$= 0.7\sqrt{dT_o}$$

$r_1$  = half-width of reinforcement zone (equal to  $D_o$ )

$r_o$  = radius of curvature of external contoured portion of outlet measured in the plane containing the axes of the run and branch. This is subject to the following limitations:

(a) *Minimum Radius.* This dimension shall not be less than  $0.05d$ , except that on branch diameters larger than 30 in., it need not exceed 1.50 in.

(b) *Maximum Radius.* For outlet pipe sizes NPS 8 and larger, this dimension shall not exceed  $0.10d + 0.50$  in. For outlet pipe sizes less than NPS 8, this dimension shall not be greater than 1.25 in.

(c) When the external contour contains more than one radius, the radius on any arc sector of approximately 45 deg shall meet the requirements of (a) and (b) above.

(d) Machining shall not be employed to meet the above requirements.

$T_b$  = actual thickness of branch wall, not including corrosion allowance

$t_b$  = required thickness of branch pipe according to the steel pipe design formula of [para. PL-3.7.1\(a\)](#), but not including any thickness for corrosion

$T_o$  = corroded finished thickness of extruded outlet measured at a height equal to  $r_o$  above the outside surface of the run

$T_r$  = actual thickness of the run wall, not including the corrosion allowance

$t_r$  = required thickness of the run according to the steel pipe design formula of [para. PL-3.7.1\(a\)](#), but not including any allowance for corrosion or underthickness tolerance

### F-2 EXAMPLES ILLUSTRATING THE APPLICATION OF THE RULES FOR REINFORCEMENT OF WELDED BRANCH CONNECTIONS

#### F-2.1 Example 1

(23)

An NPS 8 outlet is welded to an NPS 24 header. The header material is ASTM A139D with a 0.312-in. wall. The outlet is ASTM A139B Schedule 40 with a 0.322-in. wall. The working pressure,  $P$ , is 650 psig. The fabrication is in Location Class 2. Using [Table IP-2.2.9-1](#), the joint efficiency for 100% radiography is 1.00. The temperature is 100°F, and  $S$  = allowable stress. Design factors  $F = 0.60$ ,  $E = 1.00$ , and  $T = 1.00$ . For dimensions, see [Figure F-2.1-1](#).

**F-2.1.1 Header.** Nominal wall thickness required

$$t = \frac{PD}{2SFET} = \frac{650 \times 24}{2 \times 46,000 \times 0.60 \times 1.00 \times 1.00} = 0.283 \text{ in.}$$

Excess thickness in header wall

$$H - t = 0.312 - 0.283 = 0.029 \text{ in.}$$

**F-2.1.2 Outlet.** Nominal wall thickness required

$$t_b = \frac{650 \times 8.625}{2 \times 35,000 \times 0.60 \times 1.00 \times 1.00} = 0.133 \text{ in.}$$

Excess thickness in outlet wall

$$B - t_b = 0.322 - 0.133 = 0.189 \text{ in.}$$

Inside diameter of opening

$$d = 8.625 - 2 \times 0.322 = 7.981 \text{ in.}$$

**F-2.1.3 Reinforcement Required**

$$A_R = dt = 7.981 \times 0.283 = 2.259 \text{ in.}^2$$



Figure F-1-1

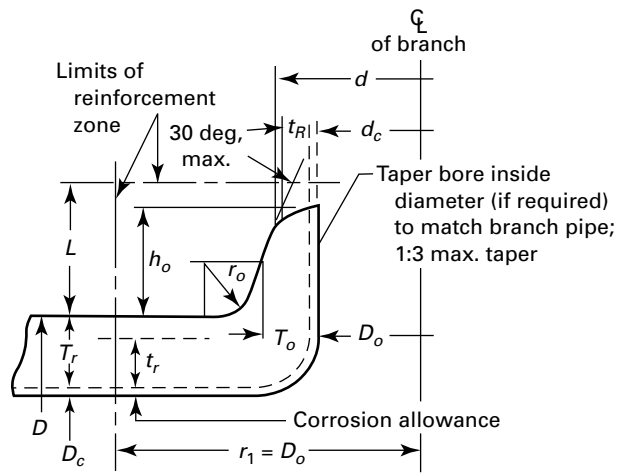
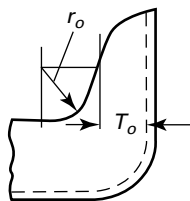


Figure F-1-2

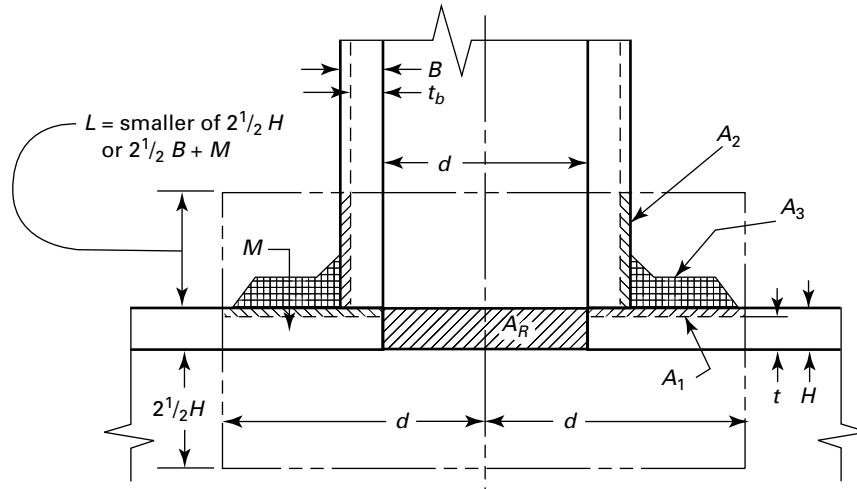


GENERAL NOTE: Figure to show method of establishing  $T_o$  when the taper encroaches on the crotch radius.





Figure F-2.1.5-1



Area of reinforcement enclosed by ———— lines.

Reinforcement area required  $A_R = dt$

Area available as reinforcement =  $A_1 + A_2 + A_3$

$A_1 = (H - t)(d)$  (if negative, use zero for value of  $A_1$ )

$A_2 = 2(B - t_b)L$

$A_3$  = summation of area of all added reinforcement, including weld areas that lie within the area of reinforcement

$A_1 + A_2 + A_3$  must be equal to or greater than the  $A_R$

where

$B$  = nominal wall thickness of branch

$d$  = the greater of the length of the finished opening in the header wall measured parallel to the axis of the run or the inside diameter of the branch connection

$H$  = nominal wall thickness of header

$M$  = actual (by measurement) or nominal thickness of added reinforcement

$t$  = required nominal wall thickness of the header (under the appropriate section of the Code)

$t_b$  = required nominal wall thickness of the branch (under the appropriate section of the Code)



# NONMANDATORY APPENDIX G

## GUIDELINE FOR HIGHER FRACTURE TOUGHNESS STEEL IN GASEOUS HYDROGEN SERVICE FOR PIPELINES AND PIPING SYSTEMS

### G-1 MICROSTRUCTURE

Microstructure plays an important role in achieving higher fracture toughness in the presence of gaseous hydrogen up to 20.7 MPa (3,000 psi). Alloy and steel processing design influences final steel microstructure formation. The desired steel microstructure is one of polygonal ferrite and acicular ferrite as uniformly distributed through the steel cross section. The following should be specified to obtain the desired steel microstructure:

- (a) Carbon content shall not exceed 0.07%.
- (b) The steel shall be niobium/columbium (Nb/Cb) microalloyed.
- (c) Carbon equivalent P<sub>cm</sub> shall be as specified below:
  - (1) API 5L X52 – X60, P<sub>cm</sub>: 0.15% maximum
  - (2) API 5L X65 – X80, P<sub>cm</sub>: 0.17% maximum
 P<sub>cm</sub> should be calculated by the following formula:

$$P_{cm} = C + Si/30 + Mn/20 + Cu/20 + Ni/60 + Cr/20 + Mo/15 + V/10 + 5B$$

(d) A slab macro etch test or other equivalent method shall be used to identify alloy centerline segregation during the continuous casting process. Use of sulfur prints is not an equivalent method. The slab macro etch test must be carried out on the first or second slab of each casting sequence and graded with an acceptance criterion of two maximum on the Mannesmann scale of 1 to 5 or equivalent.

(e) Thermo Mechanical Control Processing (TMCP) shall be used in steel making.

(f) Grain size shall be ASTM 9 or finer.

INTENTIONALLY LEFT BLANK



# ASME CODE FOR PRESSURE PIPING, B31

|                   |   |
|-------------------|---|
| B31.1-2022        | Power Piping  |
| B31.3-2022        | Process Piping  |
| B31.3-2010        | Tuberías de Proceso   |
| B31.4-2022        | Pipeline Transportation Systems for Liquids and Slurries  |
| B31.5-2022        | Refrigeration Piping and Heat Transfer Components   |
| B31.8-2022        | Gas Transmission and Distribution Piping Systems  |
| B31.8S-2022       | Managing System Integrity of Gas Pipelines  |
| B31.8S-2010       | Gestión de Integridad de Sistemas de Gasoductos   |
| B31.9-2020        | Building Services Piping  |
| B31.12-2023       | Hydrogen Piping and Pipelines   |
| B31E-2008         | Standard for the Seismic Design and Retrofit of Above-Ground Piping Systems   |
| B31G-2023         | Manual for Determining the Remaining Strength of Corroded Pipelines: Supplement to ASME B31 Code for Pressure Piping                                  |
| B31G-2012         | Manual para la determinación de la resistencia remanente de tuberías corroídas  |
| B31J-2023         | Stress Intensification Factors ( <i>i</i> -Factors), Flexibility Factors ( <i>k</i> -Factors), and Their Determination for Metallic Piping Components |
| B31J-2008 (R2013) | Método de prueba estándar para determinar factores de intensificación de esfuerzo (Factores <i>i</i> ) para componentes de tuberías metálicas         |
| B31P-2023         | Standard Heat Treatments for Piping   |
| B31Q-2021         | Pipeline Personnel Qualification  |
| B31Q-2010         | Calificación del personal de líneas de tuberías   |
| B31T-2018         | Standard Toughness Requirements for Piping  |

The ASME Publications Catalog shows a complete list of all the Standards published by the Society. For a complimentary catalog, or the latest information about our publications, call 1-800-THE-ASME (1-800-843-2763).

# ASME Services

ASME is committed to developing and delivering technical information. At ASME's Customer Care, we make every effort to answer your questions and expedite your orders. Our representatives are ready to assist you in the following areas:

|                              |                            |                                  |
|------------------------------|----------------------------|----------------------------------|
| ASME Press                   | Member Services & Benefits | Public Information               |
| <i>Codes &amp; Standards</i> | Other ASME Programs        | Self-Study Courses               |
| Credit Card Orders           | Payment Inquiries          | Shipping Information             |
| IMEchE Publications          | Professional Development   | Subscriptions/Journals/Magazines |
| Meetings & Conferences       | Short Courses              | Symposia Volumes                 |
| Member Dues Status           | Publications               | Technical Papers                 |

## How can you reach us? It's easier than ever!

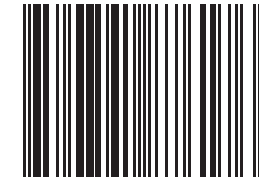
There are four options for making inquiries\* or placing orders. Simply mail, phone, fax, or E-mail us and a Customer Care representative will handle your request.

|                           |                                      |                     |                        |
|---------------------------|--------------------------------------|---------------------|------------------------|
| <i>Mail</i>               | <i>Call Toll Free</i>                | <i>Fax—24 hours</i> | <i>E-Mail—24 hours</i> |
| <b>ASME</b>               | <b>US &amp; Canada:</b> 800-THE-ASME | 973-882-1717        | customercare@asme.org  |
| 150 Clove Road, 6th Floor | (800-843-2763)                       | 973-882-5155        |                        |
| Little Falls, New Jersey  | <b>Mexico:</b> 95-800-THE-ASME       |                     |                        |
| 07424-2139                | (95-800-843-2763)                    |                     |                        |

\*Customer Care staff are not permitted to answer inquiries about the technical content of this code or standard. Information as to whether or not technical inquiries are issued to this code or standard is shown on the copyright page. All technical inquiries must be submitted in writing to the staff secretary. Additional procedures for inquiries may be listed within.

# ASME B31.12-2023

ISBN 978-0-7918-7617-6



9 780791 876176



A 1 7 9 2 3